



10810 W LITTLE YORK RD. STE 130- HOUSTON TX 77041-4051

VOICE: 713-973-6905 - FAX: 713-973-9352

web: www.twrlighting.com

IMPORTANT!!!!

PLEASE TAKE THE TIME TO FILL OUT THE FORM COMPLETELY. FILE IN A SAFE PLACE. IN THE EVENT YOU EXPERIENCE PROBLEMS WITH OR HAVE QUESTIONS CONCERNING YOUR BEACON, THE FOLLOWING INFORMATION IS NECESSARY TO OBTAIN PROPER SERVICE AND PARTS.

MODEL #

REDSTAR (FAA L-864 BEACON)

SERIAL #

PURCHASE DATE

PURCHASED FROM





THIS PAGE IS INTENTIONALLY LEFT BLANK



Questions or information beyond this manual, please contact TWR Lighting, Inc.

TWR Lighting, Inc.

10810 W Little York Rd. Ste 130 - Houston, TX 77041-4051

Voice: **713-973-6905** - Fax: **713-973-9352** – Toll Free: **800-661-8606**

E-mail: techsupport@twrlighting.com

web: www.twrlighting.com

The use of Non-original manufacturer parts which are not approved by TWR Lighting, Inc. may invalidate the warranty as well as compliance with requirements as published in the FAA Advisory Circulars AC70/7460-1M, AC150/5345-43J and AC150/5345-53 and ICAO Annex 14 Volume 2 standards.

DISCLAIMER

While every effort has been made to provide a complete, up-to-date, accurate manual, no liability claims for damages resulting from any errors or omissions in this manual will be accepted by TWR Lighting, Inc.

COPYRIGHT

Copyright © 2005 TWR Lighting, Inc.

All rights reserved. Reproduction or use of any part of this installation & operation manual is prohibited without express written permission from TWR Lighting, Inc.



Contents

1	GENERAL INFORMATION	6
1.1	Optional User Interface functions	6
1.1.1	Control options	6
2	INSTALLATION	6
2.1	L864 Beacon Light (Part # REDSTAR)	7
2.1.1	Beacon mounting.....	7
2.1.2	Beacon electrical.....	7
2.2	Cable (Part # LCABLE-2).....	7
2.2.1	Cable specifications	7
2.2.2	Cable connection	7
2.3	Optional: ADLS Junction Box (Part # JBWT-ADLS)	8
	(Aircraft Detection Lighting Systems)	8
2.3.1	JB mounting	8
2.3.2	JB electrical connection	8
2.3.3	JB beacon connections	8
2.3.4	JB alarm monitoring connection.....	8
2.3.5	JB Ethernet connection.....	8
3	OPERATION	9
3.1	JP202 Jumper Functions	9
3.1.1	JP202 Position 1	9
3.1.2	JP202 Positions 2 & 3.....	9
3.2	Input and Output.....	10
3.2.1	Beacon Alarm.....	10
3.3	LED Indicators.....	11
4	MAINTENANCE	12
4.1	Troubleshooting	12
4.1.1	No Power: (Note: REDSTAR ONLY OPERATES IN NIGHT MODE).....	12
4.1.2	No Mode Change (Beacon Photocell).....	12
4.1.3	GPS Failure:.....	12
4.1.4	Beacon Alarms:	12



5	MAJOR COMPONENTS PARTS LIST.....	13
6	WARRANTY AND RETURN POLICY.....	14
6.1	RMA FORM.....	17
7	Drawing - REDSTAR BEACON CHASSIS	18
8	Drawing - CABLE DATA SHEET	18
9	Drawing – LIGHT KIT FOR WIND TURBINE.....	18
10	Drawing – (OPTIONAL) ADLS JUNCTION BOX DETAIL	18
11	Drawing - (OPTIONAL) ADLS LIGHTING KIT CHASSIS FOR WIND TURBINE.....	18
12	Drawing - (OPTIONAL) ADLS LIGHTING KIT SCHEMATIC FOR WIND TURBINE	18



1 GENERAL INFORMATION

The REDSTAR beacon is for lighting structures such as towers and wind turbines in accordance with the FAA Advisory Circular AC 70/7460-1M, CAR 621 and ICAO Annex 14.

The REDSTAR is equipped with red visible and infrared LEDs, photocell, and GPS for independent operation without need for controls with the ability to report failures specified by FAA, CAR and ICAO that need to be advised to proper authorities. The pigtail cable (LCABLE-2) combines power, alarms, and communication wires for ease of lighting system installation.

1.1 Optional User Interface functions

1.1.1 Control options

- a) **LC-STAR** Controller with display for a user-friendly interface allowing full access and diagnostics including Ethernet Modbus interface for use such as Aircraft Detecting Lighting System (ADLS).
- b) **JBWT-ADLS** Junction box for power & alarm terminations including Ethernet Modbus interface for Aircraft Detecting Lighting System (ADLS) or remote SCADA MODBUS TCP/IP control and monitoring.
- c) Beacon also has RS-485 MODBUS RTU Slave interface for direct local control and monitoring by customer SCADA system.

2 INSTALLATION

Before installing the REDSTAR beacon read this manual completely. Check equipment for damage if damage is evident report to TWR technical server before proceeding.

Suggested tools:

1. #1 flat head cabinet tip screwdriver (small for spring terminal blocks)
2. 18" Crescent wrench
3. Electrical Multi-Meter (Able to measure up to 40Mega-ohms of resistance)

Note: System warranty is to be declared null and void if this lighting system is not installed according to instructions and diagrams within this manual.

2.1 L864 Beacon Light (Part # *REDSTAR*)

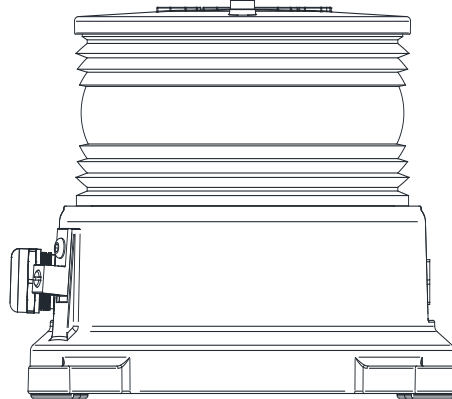

Figure 1 *REDSTAR BEACON*

2.1.1 Beacon mounting

The Beacon has four mounting feet arranged every 90 degrees on a 13-1/4" bolt hole circle. It will be necessary to have bracket and/or hardware for mounting on structure. Refer to mounting dimension on the Beacon drawing toward the back of this manual.

2.1.2 Beacon electrical

The standard beacon operates on 120/240 VAC 50/60Hz power (15 Watts during night operation). Optional 24/48 VDC beacons are available. Refer to the beacon drawing toward the back of this manual.

2.2 Cable (Part # *LCABLE-2*)

2.2.1 Cable specifications

TWR uses a single composite PVC jacketed cable with 0.655-inch diameter using 2x 12awg (Black and White) for power, 1x 14awg (Green) for ground, 4x 22awg (Blue, Yellow and Orange, Gray) for communications and 2x 22awg (Red and Tan) for alarms. All shield wires must be twisted together and terminated to ground, **except within REDSTAR Beacon do not terminate, cut of shield wires.**

2.2.2 Cable connection

LCABLE-2 cable uses a cord connector/cable gland over PVC jacket of cable for watertight entry. Refer to drawings toward the back of this manual.



2.3 Optional: ADLS Junction Box (Part # *JBWT-ADLS*)

(Aircraft Detection Lighting Systems)

2.3.1 JB mounting

The ADLS junction box (JBWT-ADLS) is typically installed at the base of a structure or within wind turbine nacelle. The junction box has mounting feet 8.39" x 13.08". Refer to details on the Chassis layout drawing toward the back of this manual.

2.3.2 JB electrical connection

Route your specific Electrical power input through the base of enclosure by a ¾" NPT hub. Installation should be in accordance with local methods and National Electrical Codes (NEC).

2.3.3 JB beacon connections

Maximum of two REDSTAR cable glands entries are available through the base of the enclosure with terminal connections for power, data, and alarms.

2.3.4 JB alarm monitoring connection

One alarm entry through base of enclosure is for monitoring beacon to indicate if light has failed through a relay prewired to normally closed. Normally open is available within REDSTAR base pcb, see operation section.

2.3.5 JB Ethernet connection

One RJ45 Ethernet connection is at base of enclosure for ADLS communications.



3 OPERATION

REDSTAR is factory configured to operate without additional setup, simple apply required voltage.

During initial power up unit will take a few minutes to initialize and receive GPS satellite synchronization. Alarm condition will clear after initialization indicating system is functioning without fault. **REDSTAR will not come on during the daylight without the photocell receiving required minimum ambient light. (Photocell is Inside the beacon lens on the opposite side of leveling bubble)**

TWR technical service is available 24/7 and can assist you with measurements at **(800) 679-8724**.

3.1 JP202 Jumper Functions

3.1.1 JP202 Position 1

a) 120 Ohm terminator resistor

- i. Jumper to be installed on beacons that are at the ends of the RS485 communication bus.
- ii. Lights in the middle of the string should not be terminated.

3.1.2 JP202 Positions 2 & 3

a) Bias voltage supply for RS485 A and B signal lines.

- i. The jumpers are to be installed on the single light installations.
- ii. On multiple light installations jumper should only be installed on the light at the end of the RS485 bus.
- iii. Both positions 2 & 3, jumpers must be installed, as loss of communication can occur if only of them is installed.

3.2 Input and Output

3.2.1 Beacon Alarm

Mechanical Relay - REDSTAR alarm is normally closed (NC) and will open if failure occurs. Normally **open** (NO) is available within REDSTAR base pcb, see detail of connection in the following image. Alarm wires: Red is "NC" or "NO" and tan is (C) common.

Alarm relay rating:

* Alarm relay is also software reconfigurable for both Energizing or De-Energizing on failure.

OUT1 (+,-)

Solid-State Relay

60V DC/AC 100mA max.

On/Off toggling with flash code, default operating mode

IN1 (+,-)

Opto-isolated Input

12/24VDC min 10mA

Not Enable, default operating mode

12VDC OUT (+,-)

Isolated 12VDC 1W power supply

Optional Bias voltage for inputs and outputs

Contact Data	
Contact arrangement	2 form C (CO)
Max. switching voltage	220VDC, 250VAC
Rated current	3A
Limiting continuous current, 85°C	3A
Contact material	AgNi, gold-covered
Min. recommended contact load	10mA at 20mV
Minimum switching voltage	100µV
Initial contact resistance	<100mΩ at 10mA, 20mV
Frequency of operation without load	max. 50 operations/s
Operate / release time max.	6ms/4ms
Bounce time max.	5 ms
Electrical endurance	
at 230VAC/0.5A	typ. 3x10 ⁵ operations
at 6VDC/0.1A	typ. 2x10 ⁶ operations
at 30VDC/1A	typ. 5x10 ⁵ operations
at 30VDC/2A	typ. 1x10 ⁵ operations
UL contact ratings	
	60 VDC, 0.3 A
	30 VDC, 1 A
	24 VDC, 1.25 A
	42.4 V peak, 50/60 Hz, 0.5 A
	42.4 V peak, 50/60 Hz, 1 A
(2 NO/NC contacts provided)	
Mechanical endurance	typ. 15x10 ⁶ operations

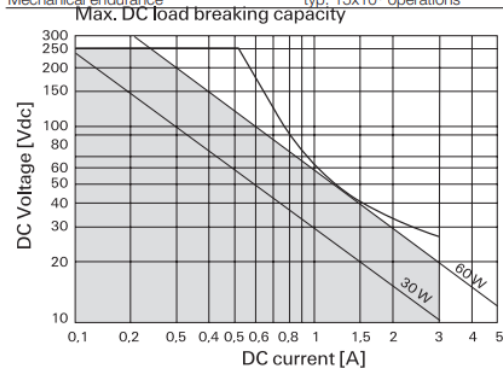

Figure 2 Alarm Relay Rating

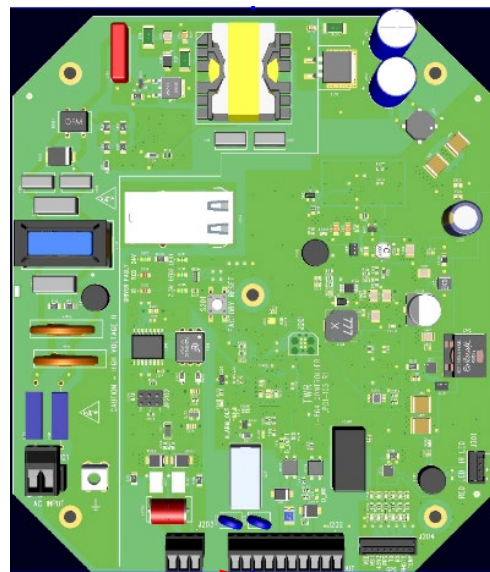
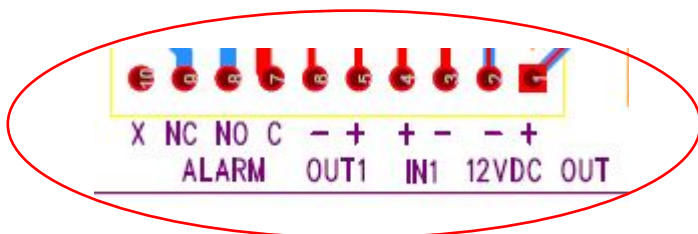

Figure 3 Power Supply



3.3 LED Indicators

REDSTAR Beacon Indicator Legend:

- a) Driver Fault (IR, RED)
 - 1. Red on Fault, normally off
 - 2. Shows fault in either LED driver or LEDs
- b) 24V
 - 1. Green, normally on
 - 2. Shows 24VDC supply voltage present
- c) 3.3V
 - 1. Green, normally on
 - 2. Shows 3.3VDC supply voltage present
- d) LED2
 - 1. Green, quick flashing once per second
 - 2. Shows normal microprocessor operation loop
- e) LED1
 - 1. Green, Flashing with beacon LED head
 - 2. Shows normal flash code operation loop
- f) ALARM_OUT
 - 1. Green, on when Mechanical relay is energized
 - 2. Visual indicator for Alarm Relay Status
- g) D_OUT1
 - 1. Green, on when Solid-State relay is energized
 - 2. Visual indicator for Solid-State Relay OUT1 Status
- h) D_IN1
 - 1. Green, on when 12/24VDC voltage present on Input IN1 terminals
 - 2. Visual indicator for IN1 status (Not Enabled)

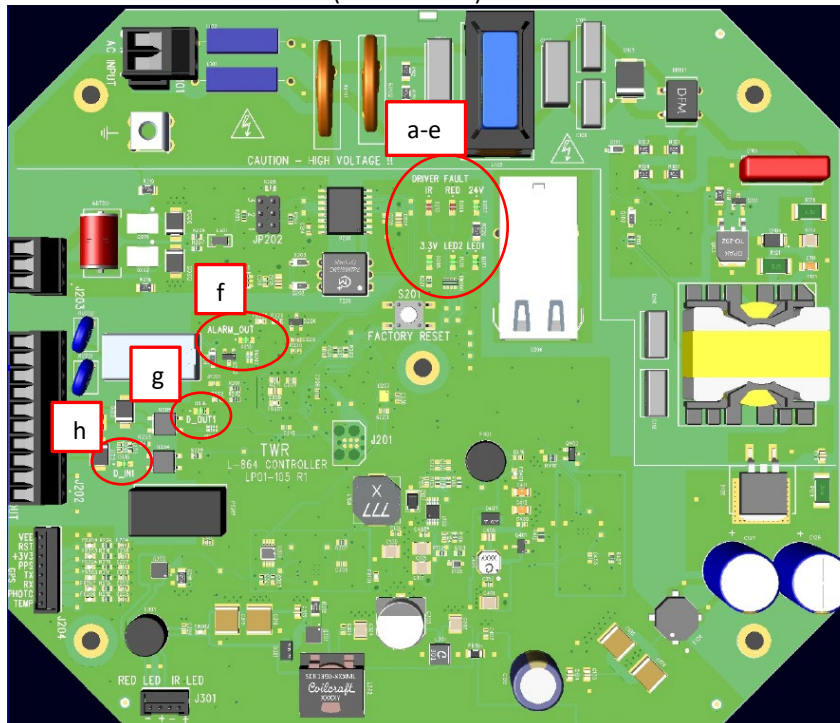

Figure 4 Power Supply LEDs



4 MAINTENANCE

This FAA L864 REDSTAR Beacon is constructed to be maintenance free. It is necessary to install all components and perform all tasks and described in this manual. Testing of opened device under voltage should be avoided if possible and when required should be carried out only by a skilled person who is aware of the hazards involved.

4.1 Troubleshooting

4.1.1 No Power: (Note: REDSTAR ONLY OPERATES IN NIGHT MODE)

- a) Check that AC power is present on REDSTAR pigtail across black and white power wires.
- b) Check within base of beacon at power termination to confirm power is present. Opening device under voltage should be carried out only by a skilled person who is aware of the hazards involved.
- c) AC power is present if green indicator is lit see image on section 3.

4.1.2 No Mode Change (Beacon Photocell)

- a) If photocell fails, REDSTAR will provide failure alarm.
- b) Power cycle the beacon.

4.1.3 GPS Failure:

- a) If the GPS fails to receive signal (out of synchronization)
- b) Check that the GPS board cable is plugged in correctly and the antenna has a clear view of the sky.
- c) Power cycle the beacon.

4.1.4 Beacon Alarms:

- a) Verify the beacons has not been with or without daylight for more than 19 hours. If this is the case the beacon will reset upon normal day/night cycle.
- b) Power cycle the beacon.
- c) Check power supply pcb within beacon base for red LED on Driver fault, if present unit is in fail mode. TWR technical service is available 24/7 and can assist you with troubleshooting at (800) 679-8724.



5 MAJOR COMPONENTS PARTS LIST

No spare parts are expected to be needed during the warranty period.

In case a site requires maintaining some spare parts at hand the 'SP' marked is suggested and all parts can be bought in advance.

The warranty statement as written in this manual is applicable during the installation and daily operation.

QTY.	DESCRIPTION	PART NUMBER	SP
1	L864 Power Supply	LP01-105	Y
2	REDSTAR PIGTAIL 33' (10m)	LCABLE-2	N
1	Cable liquid tight connector	S2521	N



6 WARRANTY AND RETURN POLICY

TWR Lighting[®], Inc. (“TWR[®]”) warrants its products (other than “LED Product”) against defects in design, material (excluding incandescent bulbs) and workmanship for a period ending on the earlier of two (2) years from the date of shipment or one (1) year from the date of installation.

TWR Lighting[®], Inc. (“TWR[®]”) warrants its “LED Product” against defects in design, material, and workmanship for a period of five (5) years from the date of shipment. TWR[®], at its sole option, will, itself, or through others, repair, replace or refund the purchase price paid for “LED Product” that TWR[®] verifies as being inoperable due to original design, material, or workmanship. All warranty replacement “LED Product” is warranted only for the remainder of the original warranty of the “LED Product” replaced. Replacement “LED Product” will be equivalent in function, but not necessarily identical, to the replaced “LED Product.”

TWR Lighting[®], Inc. (“TWR[®]”) warrants its “LED Product” against light degradation for a period of five (5) years from the date of installation. TWR[®], at its sole option, will, itself, or through others, repair, replace or refund the purchase price paid for “LED Product” that TWR[®] verifies as failing to meet 75% of the minimum intensity requirements as defined in the FAA Advisory Circular 150/5345-43G dated

09/26/12. All warranty replacement “LED Product” is warranted only for the remainder of the original warranty of the “LED Product” replaced. Replacement “LED Product” will be equivalent in function, but not necessarily identical, to the replaced “LED Product.”

Replacement parts (other than “LED Product”) are warranted for 90 days from the date of shipment.

Conditions not covered by this Warranty, or which might void this Warranty are as follows:

- x Improper Installation or Operation
- x Misuse
- x Abuse
- x Unauthorized or Improper Repair or Alteration
- x Accident or Negligence in Use, Storage, Transportation, or Handling
- x Any Acts of God or Nature
- x Non-OEM Parts

The use of non-OEM parts or modifications to original equipment design will void the manufacturer warranty and could invalidate the assurance of complying with FAA requirements as published in Advisory Circular 150/5345-43.



Warranty& Return Policy(continued)

Field Service – Repairs are warranted for 90 days from the date of service, except where TWR® has made recommendations that were not adhered to that may cause premature failure on previous repairs. Labor, Travel, and Tower Climb are not covered under warranty. Customer shall be obligated to pay for all incurred charges not related to warranty. All warranty repairs are performed by trained TWR® personnel or dispatched through an extensive network of certified and insured Service Representatives.

Return Terms – You must first contact our Customer Service Department at 713-973-6905 to acquire a Return Merchandise Authorization (RMA) number to return the product(s). Please have the following information available when requesting an RMA number:

- x The contact name and phone number of the tower owner
- x The contact name and phone number of the contractor
- x The site name and number
- x The part number(s)
- x The serial number(s) (if any) x A description of the problem x The billing information
- x The Ship To address

This RMA number must be clearly visible on the outside of the box. If the RMA number is not clearly labeled on the outside of the box, your shipment will be refused. Please ensure the material you are returning is packaged carefully. The warranty is null and void if the product(s) are damaged in the return shipment.

All RMAs must be received by TWR LIGHTING®, INC., 10810 W LITTLE YORK RD. #130, HOUSTON TX 77041-4, within 30 days of issuance.

Upon full compliance with the Return Terms, TWR® will replace, repair and return, or credit product(s) returned by the customer. It is TWR's sole discretion to determine the disposition of the returned item(s).



Warranty & Return Policy (continued)

Replacements – Replacement part(s) will be shipped and billed to the customer for product(s) considered as Warranty, pending return of defective product(s). When available, a certified reconditioned part is shipped as warranty replacement with a Return Merchandise Authorization (RMA) number attached. Upon receipt of returned product(s), inspection, testing, and evaluation will be performed to determine the cause of defect. The customer is then notified of the determination of the testing.

- x Product(s) that is deemed defective and/or unrepairable and covered under warranty - a credit will be issued to the customer's account.
- x Product(s) found to have no defect will be subject to a \$75.00 per hour testing charge (1 hour minimum), which will be invoiced to the customer. At this time, the customer may decide to have the tested part(s) returned and is responsible for the return charges.
- x Product(s) under warranty, which the customer does not wish returned, the customer will be issued a credit against the replacement invoice.

Repair & Return – A Return Merchandise Authorization (RMA) will be issued for all part(s) returned to TWR® for repair. Upon receipt of returned product(s), inspection, testing and evaluation will be performed to determine the cause of defect. The customer is then notified of the determination of the testing. If the returned part(s) is deemed unrepairable, or the returned part(s) is found to have no defect, the customer will be subject to a \$75.00 per hour testing charge (1 hour minimum), which will be invoiced to the customer. Should the returned parts be determined to be repairable, a written estimated cost of repair will be sent to the customer for their written approval prior to any work being performed. To have the tested part(s) repaired and/or returned, the customer must issue a purchase order and is responsible for the return shipping charges.

Return to Stock – Any order that is returned to TWR® for part(s) ordered incorrectly by the customer, or unneeded upon receipt, the customer is required to pay a 20% restocking fee. A credit will be issued once it is determined that the Return Terms are met.

Credits – Credits are issued once it is determined that all the Warranty and Return Terms are met. All credits are processed on Fridays. In the event a Friday falls on a Holiday, the credit will be issued on the following Friday.

Freight – All warranty replacement part(s) will be shipped via ground delivery and paid for by TWR®. Delivery other than ground is the responsibility of the customer.

REMEDIES UNDER THIS WARRANTY ARE LIMITED TO PROVISIONS OF REPLACEMENT PARTS AND REPAIRS AS SPECIFICALLY PROVIDED. IN NO EVENT SHALL TWR® BE LIABLE FOR ANY OTHER LOSSES, DAMAGES, COSTS OR EXPENSES INCURRED BY THE CUSTOMER, INCLUDING, BUT NOT LIMITED TO, LOSS FROM FAILURE OF THE PRODUCT(S) TO OPERATE FOR ANY TIME, AND ALL OTHER DIRECT, INDIRECT, SPECIAL, INCIDENTAL, OR CONSEQUENTIAL DAMAGES, INCLUDING ALL PERSONAL INJURY OR PROPERTY DAMAGE DUE TO ALLEGED NEGLIGENCE, OR ANY OTHER LEGAL THEORY WHATSOEVER. THIS WARRANTY IS MADE BY TWR® EXPRESSLY IN LIEU OF ALL OTHER WARRANTIES, WHETHER EXPRESSED OR IMPLIED. WITHOUT LIMITING THE GENERALITY OF THE FORGOING, TWR® MAKES NO WARRANTY OF MERCHANTABILITY OR FITNESS OF THE PRODUCT(S) FOR ANY PARTICULAR PURPOSE. TWR® EXPRESSLY DISCLAIMS ALL OTHER WARRANTIES.



6.1 RMA FORM

RMA-Form

	RETURN MATERIAL AUTHORIZATION FORM	
Please send this form together with the defect product to TWR Lighting, Inc.		
TWR Lighting, Inc. reference RMA #	:	
Date (mm-dd-yyyy)	:	
Number of pages	:	1 of
Customer name	:	
Contact person	:	
Delivery address	:	TWR Lighting, Inc., 10810 W Little York Rd. #130 Houston, Tx 77041
Department	:	Service
Telephone	:	(713) 973-6905
Fax	:	(713) 973-9352
Dear customer,		
Please fill in this form completely and return it to the above fax number without indicating an RMA number. The RMA number will be immediately generated by us. Please complete the following questions. Use one sheet for each item that is returned.		
Customer reference RMA nr.	:	
Site location	:	
Product type	:	
Serial number	:	
Reason for return delivery	:	
Initial TWR Lighting, Inc. PO (order) number	:	
Warranty claimed	:	Yes / No
Replacement product needed in advance?	:	Yes / No
Inspection costs in the amount of \$75.00 will be charged for each product. When a replacement product is ordered, the inspection cost will be calculated in the price.		



- 7 Drawing - REDSTAR BEACON CHASSIS
- 8 Drawing - CABLE DATA SHEET
- 9 Drawing – LIGHT KIT FOR WIND TURBINE
- 10 Drawing – (OPTIONAL) ADLS JUNCTION BOX DETAIL
- 11 Drawing - (OPTIONAL) ADLS LIGHTING KIT CHASSIS FOR WIND TURBINE
- 12 Drawing - (OPTIONAL) ADLS LIGHTING KIT SCHEMATIC FOR WIND TURBINE

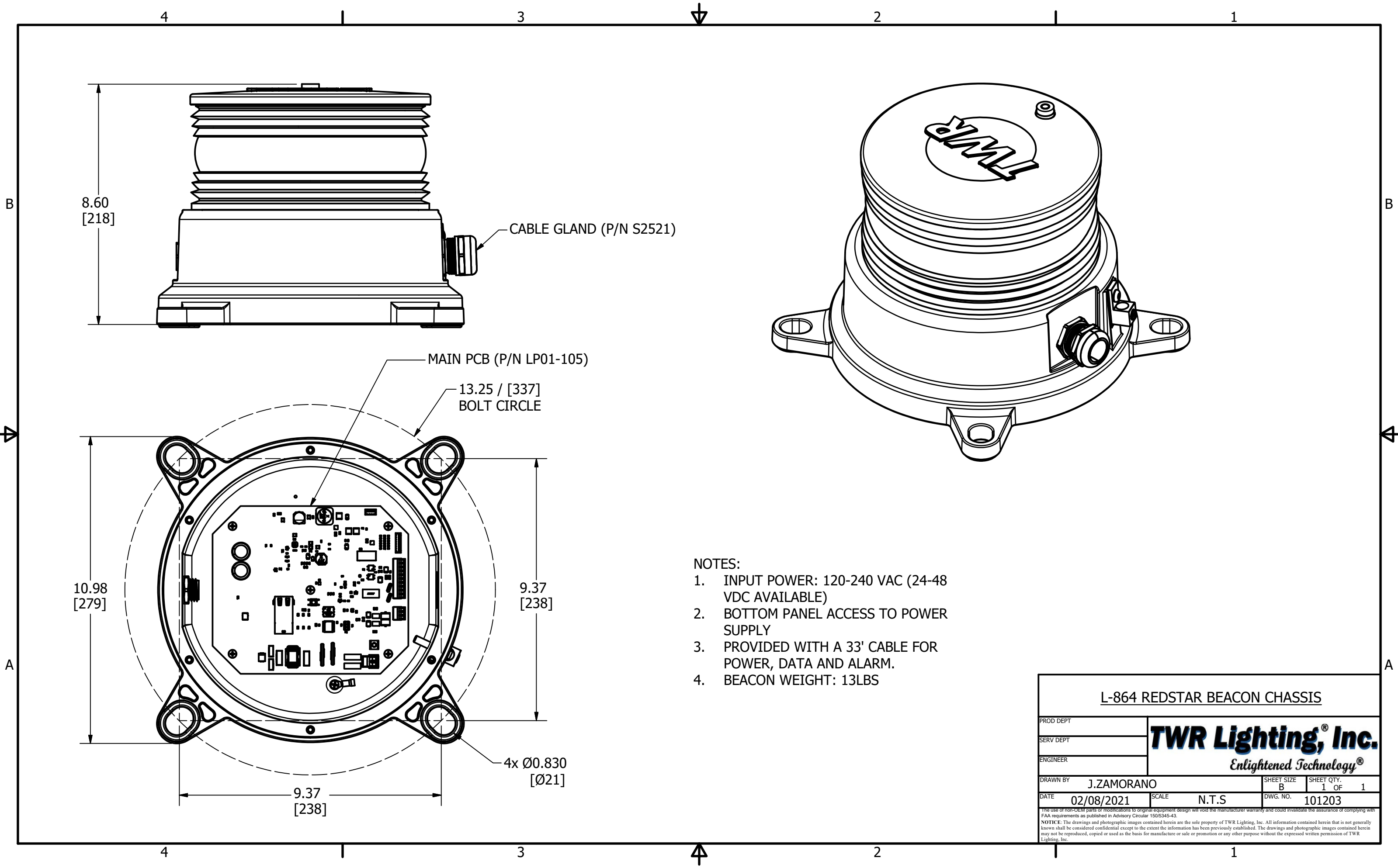

- NOTES:
1. INPUT POWER: 120-240 VAC (24-48 VDC AVAILABLE)
 2. BOTTOM PANEL ACCESS TO POWER SUPPLY
 3. PROVIDED WITH A 33' CABLE FOR POWER, DATA AND ALARM.
 4. BEACON WEIGHT: 13LBS

L-864 REDSTAR BEACON CHASSIS			
PROD DEPT		TWR Lighting, Inc. Enlightened Technology®	
SERV DEPT			
ENGINEER			
DRAWN BY	J.ZAMORANO	SHEET SIZE	B
DATE	02/08/2021	SCALE	N.T.S
		DWG. NO.	101203
		SHEET QTY.	1 OF 1

The use of non-OEM parts or modifications to original equipment design will void the manufacturer warranty and could invalidate the assurance of complying with FAA requirements as published in Advisory Circular 150/5345-43.
NOTICE: The drawings and photographic images contained herein are the sole property of TWR Lighting, Inc. All information contained herein that is not generally known shall be considered confidential except to the extent the information has been previously established. The drawings and photographic images contained herein may not be reproduced, copied or used as the basis for manufacture or sale or promotion or any other purpose without the expressed written permission of TWR Lighting, Inc.

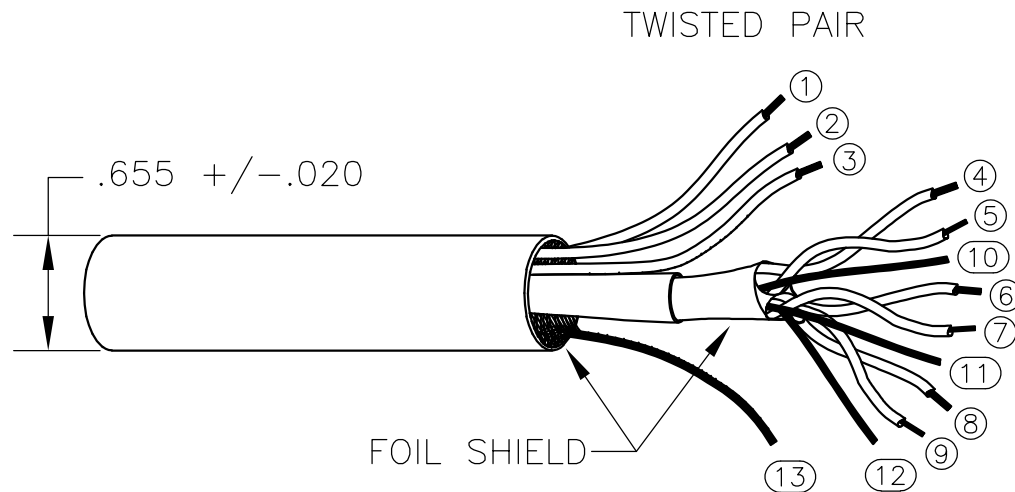

SPECIFICATION
HILS STROBE CABLE

CONDUCTOR NUMBER	AWG	TINNED COPPER WIRE STRAND	INSULATION VOLTAGE	COLOR
1	12	65/30 STRANDED	300V MIN.	BLACK
2	12	65/30 STRANDED	300V MIN.	WHITE
3	14	41/30 STRANDED	300V MIN.	GREEN
4	22	7/30 STRANDED	300V MIN.	YELLOW
5	22	7/30 STRANDED	300V MIN.	BLUE
6	22	7/30 STRANDED	300V MIN.	ORANGE
7	22	7/30 STRANDED	300V MIN.	GRAY
8	22	7/30 STRANDED	300V MIN.	RED
9	22	7/30 STRANDED	300V MIN.	TAN
10	22	7/30 STD BARE	NONE	BARE
11	22	7/30 STD BARE	NONE	BARE
12	22	7/30 STD BARE	NONE	BARE
13	14	41/30 STD BARE	NONE	BARE

GENERAL: 3X12AWG, 1X14AWG ISP PVC COMPOSITE CABLE

- 2 CONDUCTORS (12 AWG):
COLOR CODE: BLACK, WHITE,
- 1 CONDUCTOR (14 AWG):
COLOR CODE: GREEN
- 2 SHIELDED PAIR: (22 AWG):
COLOR CODE: YELLOW / BLUE / SHIELD
- 2 SHIELDED PAIR: (22 AWG):
COLOR CODE: ORANGE / GRAY / SHIELD
- 2 SHIELDED PAIR: (22 AWG):
COLOR CODE: RED / TAN / SHIELD

RATING:
UL-2464
300 VOLTS
80 DEGREE CENTIGRADE
CSA AWM I/II A/B

LCABLE-2 (LED CABLE)

TWR Lighting, Inc.

APP'D	ENGINEER	CHK'D BY	
DRAWN BY J.Z		SHEET SIZE A	SHEET QTY. 1 OF 1
DATE 12/04/2020	SCALE N.T.S.	DRAWING NO. F01-111SL	

NOTICE: This drawing is the property of TWR Lighting, Inc. All information contained herein that is not generally known shall be confidential except to the extent the information has been previously established. This drawing may not be reproduced, copied or used as the basis for manufacture or sale without written permission.

BILL OF MATERIALS

ITEM NO.	QTY.	TWR PART NO.	DESCRIPTION
1	1	L864-G	L864-G RED LED BEACON
2	1	CC-NPT34G	3/4" NPT CORD CONNECTOR

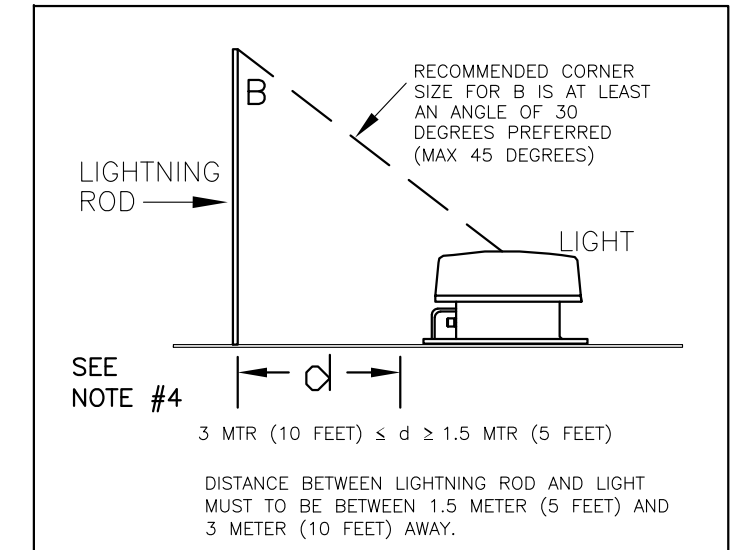
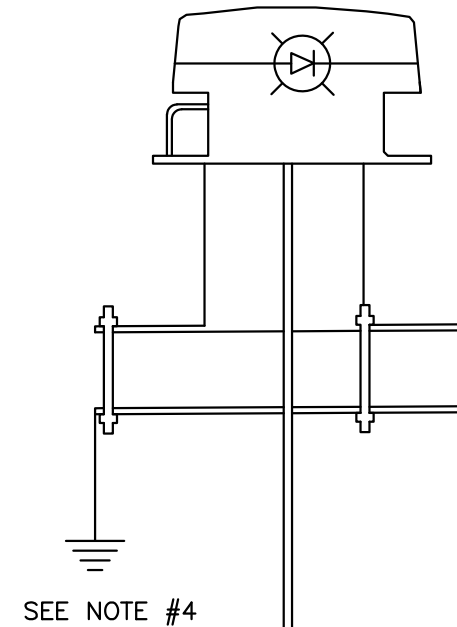
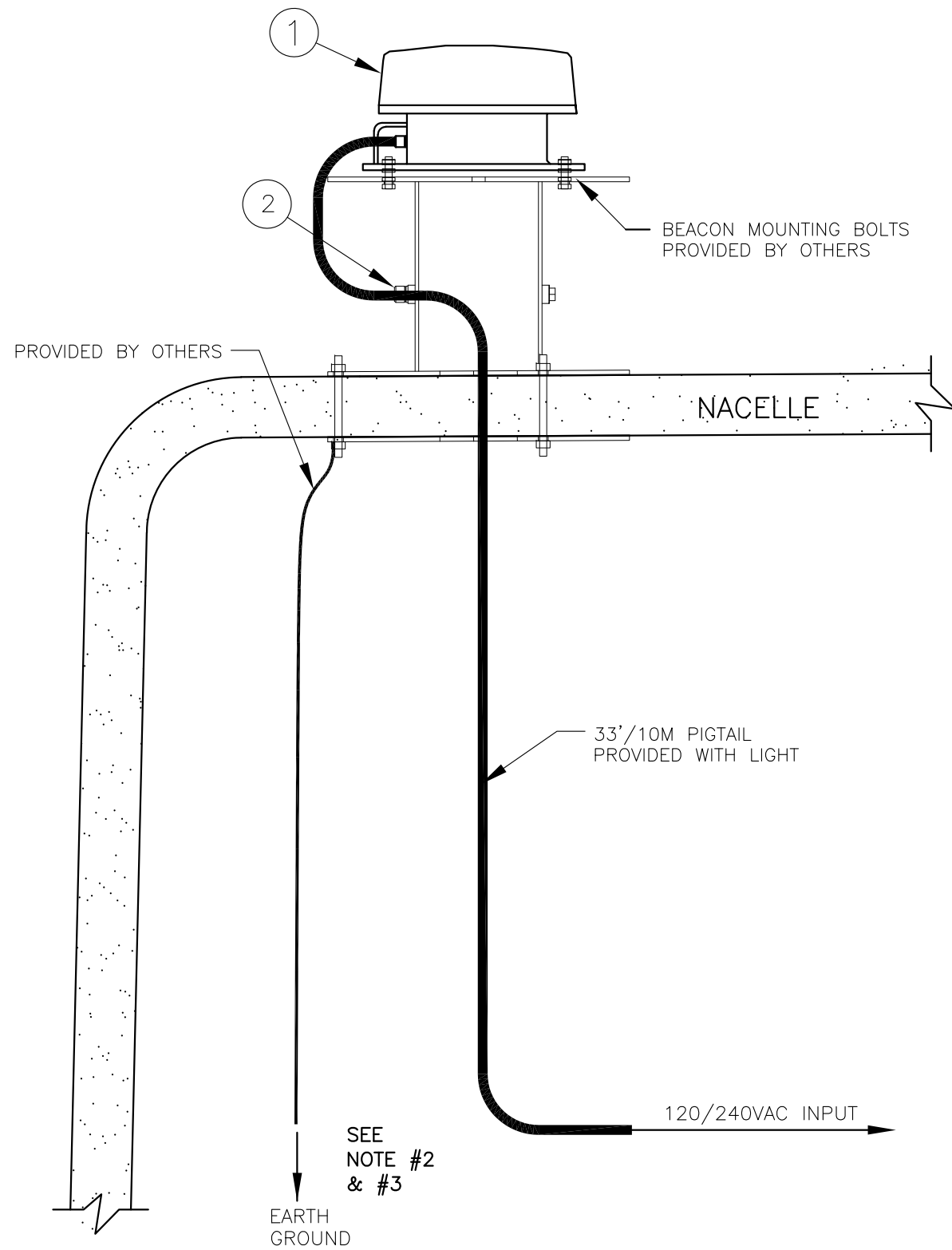

NOTES:

- 1) THIS DRAWING IS PROVIDED AS A GENERAL REFERENCE. TWR LIGHTING, INC. DOCUMENTATION SUPERSEDES THIS DRAWING & SHOULD BE REVIEWED PRIOR TO INSTALLATION OF THIS SYSTEM.
- 2) RECOMMEND MINIMUM #6 GAUGE WIRE FOR ALL GROUND CONNECTIONS.
- 3) IT IS EXTREMELY IMPORTANT TO GROUND LIGHTING SYSTEM IN ORDER TO DISSIPATE STATIC ELECTRICITY TYPICALLY ASSOCIATED WITH WIND TURBINES.
- 4) THE LIGHT(S) SHOULD BE PROTECTED BY AN AIR TERMINAL (LIGHTNING ROD) DIRECTLY CONNECTED TO THE STRUCTURE'S PRIMARY EARTHING (GROUNDING) SYSTEM. IDEALLY THE AIR TERMINAL SHOULD BE MOUNTED BETWEEN APPROX 1.5 METER (5 FEET) AND 3 METER (10 FEET) AWAY FROM THE LIGHT AND BE AT LEAST HIGH ENOUGH TO COVER THE LIGHT COMPLETELY BY AN ANGLE OF 30 DEGREES PREFERRED (MAX 45 DEGREES)

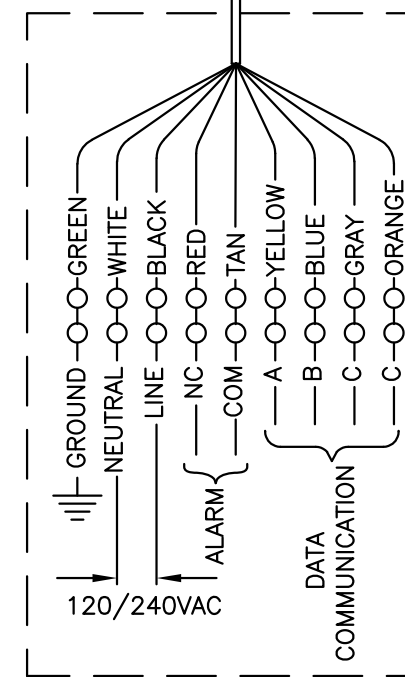

ALARM

NC = NORMALLY CLOSED
C = COMMON

○ = TERMINAL

SEE NOTE #2 & #3

WIRING DIAGRAM

L864-G LIGHTING KIT FOR WIND TURBINES

APPROVED BY		
APPROVED BY		
APPROVED BY		
DRAWN BY	SIZE	SHEET QTY.
J. ZAMORANO	B	1 OF 1
DATE	SCALE	DWG. NO.
04/16/2020	N.T.S.	101173



The use of non-OEM parts or modifications to original equipment design will void the manufacturer warranty and could invalidate the assurance of complying with FAA requirements as published in Advisory Circular 150/5345-43.
NOTICE: The drawings and photographic images contained herein are the sole property of TWR Lighting, Inc. All information contained herein that is not generally known shall be considered confidential except to the extent the information has been previously established. The drawings and photographic images contained herein may not be reproduced, copied or used as the basis for manufacture or sale or promotion or any other purpose without the expressed written permission of TWR Lighting, Inc.

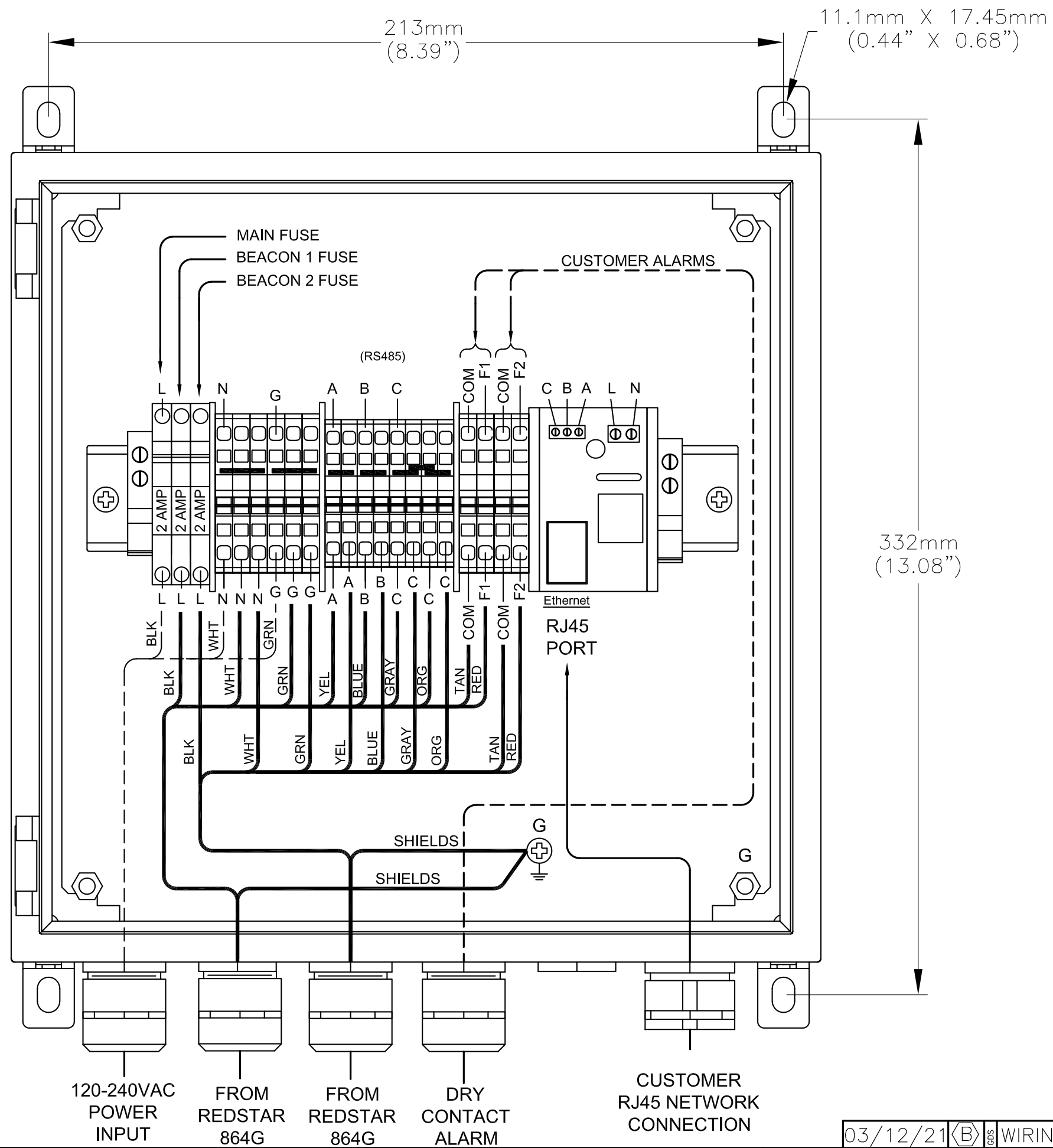

CUSTOMER ALARM POINTS

COM = COMMON
 F = FAIL OUTPUT (NORMALLY CLOSED)

NOTES:

- 1) THIS FAIL OUTPUT IS A POLARITY SENSITIVE OPEN COLLECTOR OUTPUT. IF THE POLARITY CONNECTION IS WRONG, THERE WILL BE NO FAIL SIGNAL. FAIL OUTPUT RATING: MAX 30V AT 1AMP.
- 2) WIRES ARE CONNECTED LETTER TO LETTER. (EXAMPLE) L TO L...

**ADLS JUNCTION BOX CHASSIS
 (PN:JBWT-ADLS)**

APPROVED BY	
APPROVED BY	
APPROVED BY	
DRAWN BY	G.D.S.
DATE	8/4/20
SIZE	B
SHEET QTY.	1 OF 1
SCALE	N.T.S.
DWG. NO.	101188



The use of non-OEM parts or modifications to original equipment design will void the manufacturer warranty and could invalidate the assurance of complying with FAA requirements as published in Advisory Circular 150/5345-43.
 NOTICE: The drawings and photographic images contained herein are the sole property of TWR Lighting, Inc. All information contained herein that is not generally known shall be considered confidential except to the extent the information has been previously established. The drawings and photographic images contained herein may not be reproduced, copied or used as the basis for manufacture or sale or promotion or any other purpose without the expressed written permission of TWR Lighting, Inc.

03/12/21 **B** WIRING CHANGE

BILL OF MATERIALS

ITEM NO.	QTY.	TWR PART NO.	DESCRIPTION
1	1	REDSTAR	L864 RED LED BEACON 120/240 VAC
2	1	JBWT-ADLS	JUNCTION BOX WIND ADLS

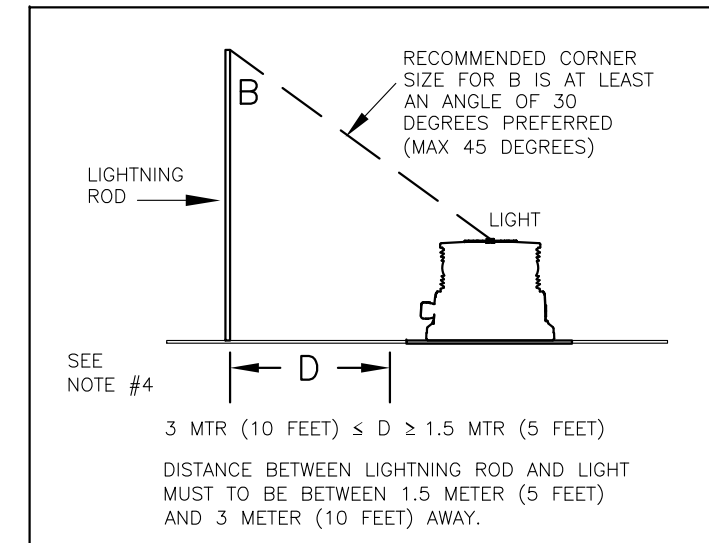
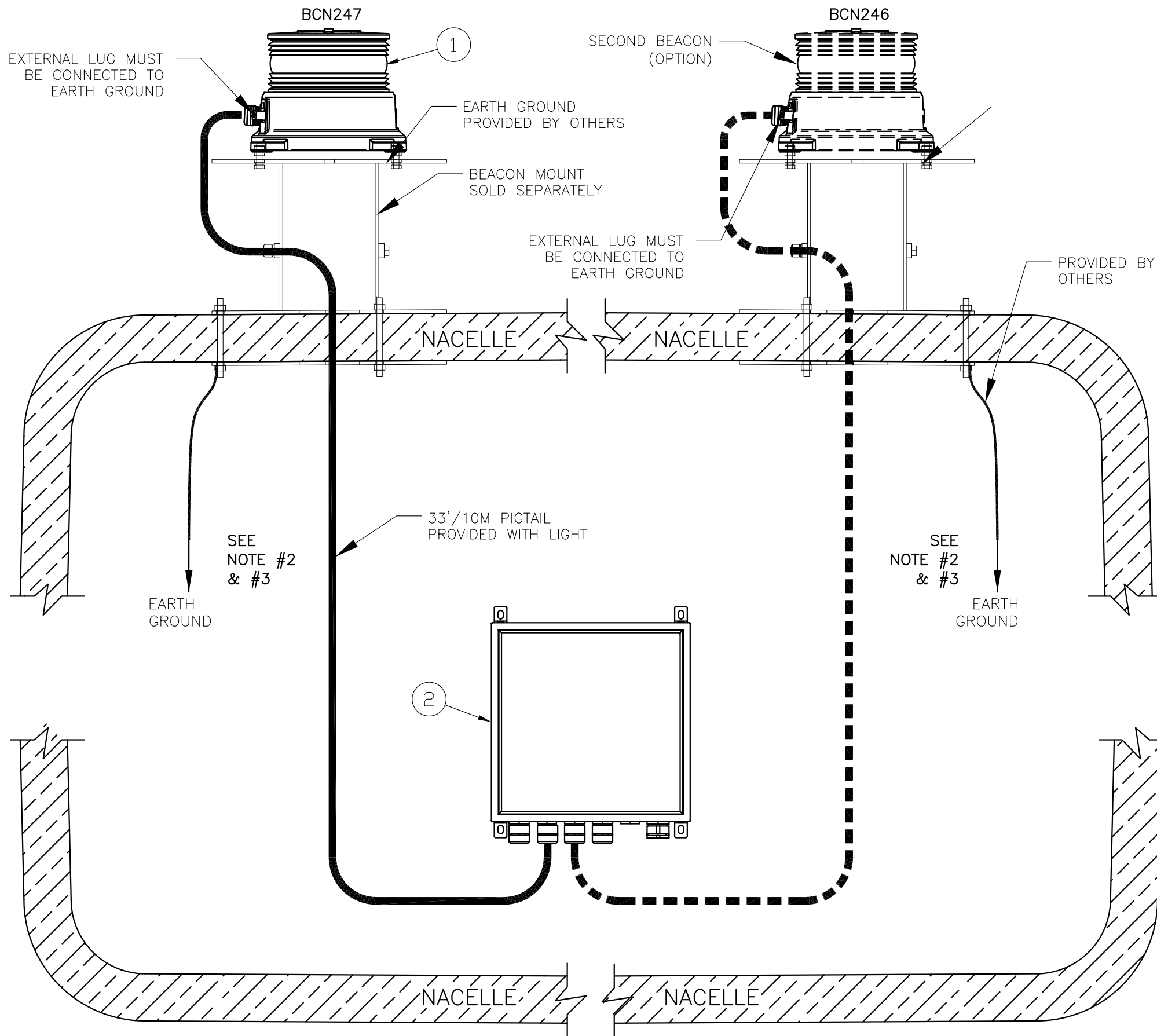

NOTES:

- 1) THIS DRAWING IS PROVIDED AS A GENERAL REFERENCE. TWR LIGHTING, INC. DOCUMENTATION SUPERSEDES THIS DRAWING & SHOULD BE REVIEWED PRIOR TO INSTALLATION OF THIS SYSTEM.
- 2) RECOMMEND MINIMUM #6 GAUGE WIRE FOR ALL GROUND CONNECTIONS.
- 3) IT IS EXTREMELY IMPORTANT TO GROUND LIGHTING SYSTEM IN ORDER TO DISSIPATE STATIC ELECTRICITY TYPICALLY ASSOCIATED WITH WIND TURBINES.
- 4) THE LIGHT(S) SHOULD BE PROTECTED BY AN AIR TERMINAL (LIGHTNING ROD) DIRECTLY CONNECTED TO THE STRUCTURE'S PRIMARY EARTHING (GROUNDING) SYSTEM. IDEALLY THE AIR TERMINAL SHOULD BE MOUNTED BETWEEN APPROX 1.5 METER (5 FEET) AND 3 METER (10 FEET) AWAY FROM THE LIGHT AND BE AT LEAST HIGH ENOUGH TO COVER THE LIGHT COMPLETELY BY AN ANGLE OF 30 DEGREES PREFERRED (MAX 45 DEGREES)
- 5) REFER TO DRAWING #101188 FOR MORE DETAIL ON JBWT-ADLS.

WTSTAR-ADLS LIGHTING KIT FOR WIND TURBINES

APPROVED BY			
APPROVED BY			
APPROVED BY			
DRAWN BY	J. ZAMORANO	SIZE B	SHEET QTY. 1 OF 2
DATE	09/14/2020	SCALE	N.T.S.
			DWG. NO. 101193

03/12/21 (A) WIRING CHANGE

The use of non-OEM parts or modifications to original equipment design will void the manufacturer warranty and could invalidate the assurance of complying with FAA requirements as published in Advisory Circular 150/5345-43.
 NOTICE: The drawings and photographic images contained herein are the sole property of TWR Lighting, Inc. All information contained herein that is not generally known shall be considered confidential except to the extent the information has been previously established. The drawings and photographic images contained herein may not be reproduced, copied or used as the basis for manufacture or sale or promotion or any other purpose without the expressed written permission of TWR Lighting, Inc.

BILL OF MATERIALS

ITEM NO.	QTY.	TWR PART NO.	DESCRIPTION
1	1	REDSTAR	L864 RED LED BEACON 120/240 VAC
2	1	JBWT-ADLS	JUNCTION BOX WIND ADLS

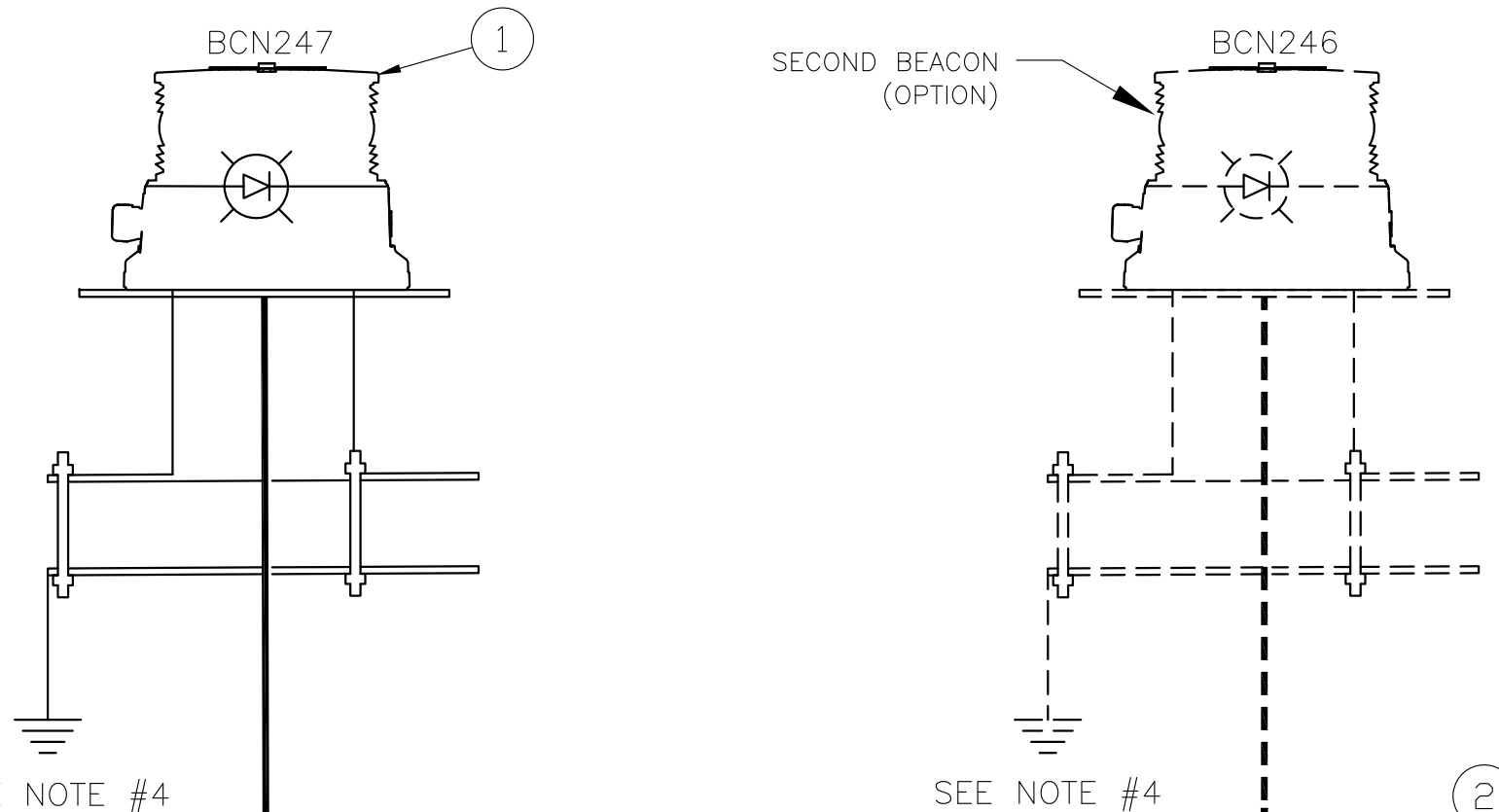
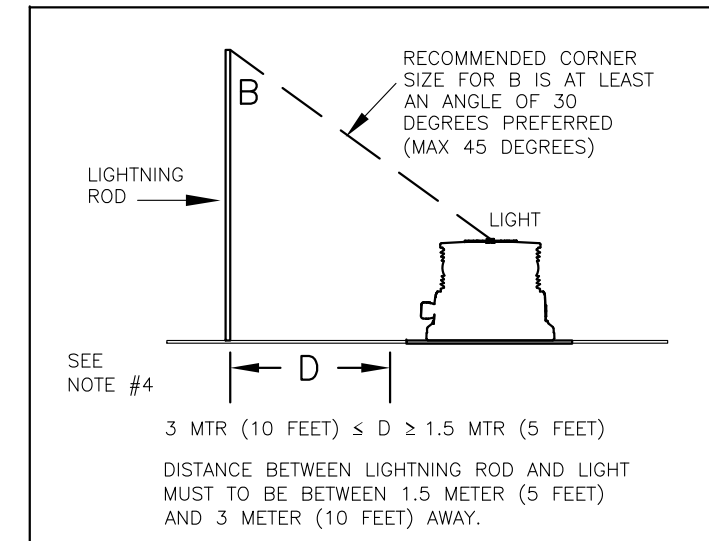

SEE NOTE #4

SEE NOTE #4

NOTES:

- 1) THIS DRAWING IS PROVIDED AS A GENERAL REFERENCE. TWR LIGHTING, INC. DOCUMENTATION SUPERSEDES THIS DRAWING & SHOULD BE REVIEWED PRIOR TO INSTALLATION OF THIS SYSTEM.
- 2) RECOMMEND MINIMUM #6 GAUGE WIRE FOR ALL GROUND CONNECTIONS.
- 3) IT IS EXTREMELY IMPORTANT TO GROUND LIGHTING SYSTEM IN ORDER TO DISSIPATE STATIC ELECTRICITY TYPICALLY ASSOCIATED WITH WIND TURBINES.
- 4) THE LIGHT(S) SHOULD BE PROTECTED BY AN AIR TERMINAL (LIGHTNING ROD) DIRECTLY CONNECTED TO THE STRUCTURE'S PRIMARY EARTHING (GROUNDING) SYSTEM. IDEALLY THE AIR TERMINAL SHOULD BE MOUNTED BETWEEN APPROX 1.5 METER (5 FEET) AND 3 METER (10 FEET) AWAY FROM THE LIGHT AND BE AT LEAST HIGH ENOUGH TO COVER THE LIGHT COMPLETELY BY AN ANGLE OF 30 DEGREES PREFERRED (MAX 45 DEGREES)
- 5) REFER TO DRAWING #101188 FOR MORE DETAIL ON JBWT-ADLS.

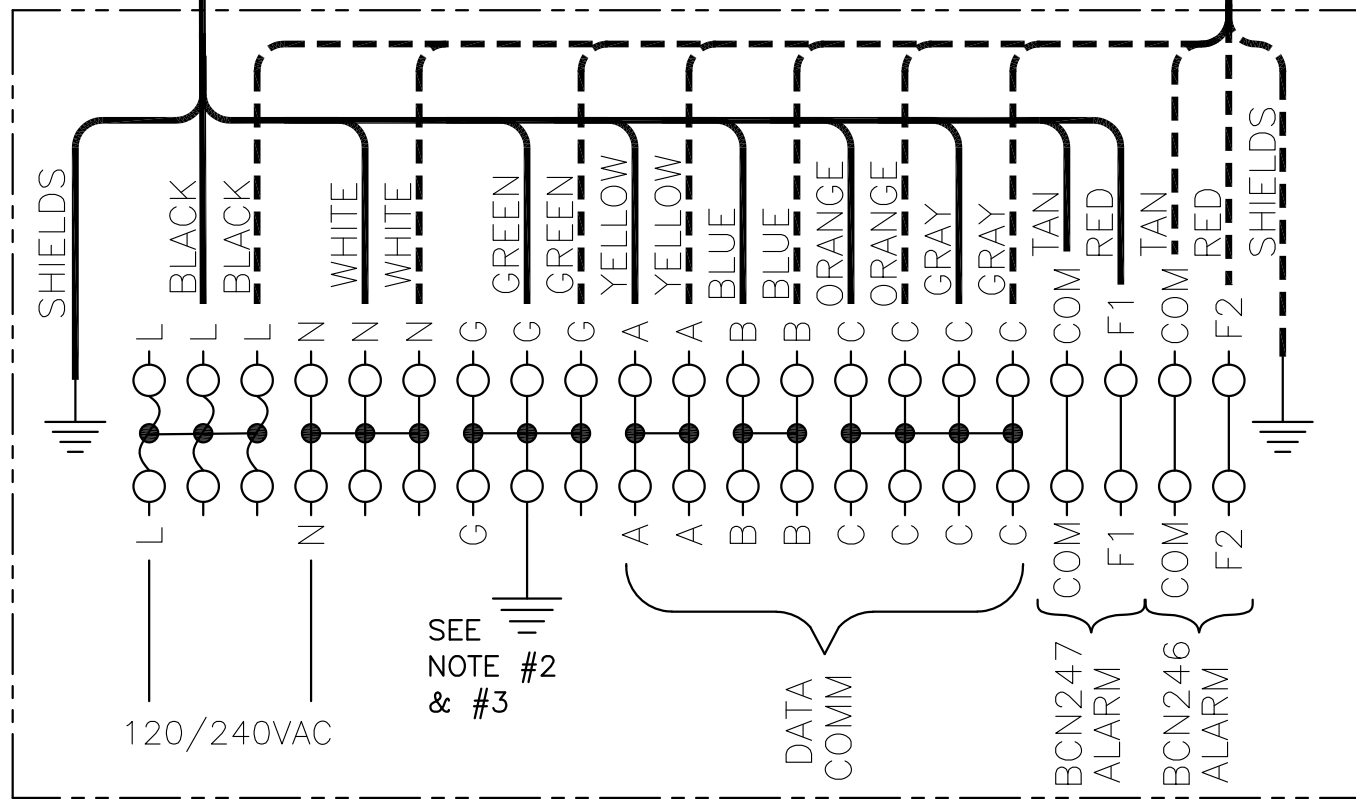

SEE NOTE #2 & #3

DATA COMM

BCN247 ALARM
COM F1
BCN246 ALARM
COM F2

CUSTOMER ALARM POINTS

COM = COMMON
F = FAIL OUTPUT (NORMALLY CLOSED)

WIRING DIAGRAM

WTSTAR-ADLS LIGHTING KIT FOR WIND TURBINES

APPROVED BY		
APPROVED BY		
APPROVED BY		
DRAWN BY	SIZE	SHEET QTY.
J. ZAMORANO	B	2 OF 2
DATE	SCALE	DWG. NO.
09/14/2020	N.T.S.	101193



03/12/21 (A) WIRING CHANGE

The use of non-OEM parts or modifications to original equipment design will void the manufacturer warranty and could invalidate the assurance of complying with FAA requirements as published in Advisory Circular 150/5345-43. NOTICE: The drawings and photographic images contained herein are the sole property of TWR Lighting, Inc. All information contained herein that is not generally known shall be considered confidential except to the extent the information has been previously established. The drawings and photographic images contained herein may not be reproduced, copied or used as the basis for manufacture or sale or promotion or any other purpose without the expressed written permission of TWR Lighting, Inc.