

TWR Lighting, Inc. **MARK**

Enlightened Technology

AA6MDFLEDPO CONTROLLER

TABLE OF CONTENTS

1.0	GENERAL INFORMATION	1
2.0	INSTALLATION	2
2.1	MOUNTING THE CONTROL CABINET	2
2.2	PHOTOCELL INSTALLATION	2
2.3	POWER WIRING.....	2
2.4	RED BEACON AND SIDELIGHT WIRING	3
3.0	THEORY OF OPERATION	3
3.1	POWER SUPPLY.....	3
3.2	SIDELIGHTS.....	3
3.3	BEACONS	4
4.0	TROUBLESHOOTING GUIDE	5
5.0	MAJOR COMPONENTS PARTS LIST	6
6.0	SUGGESTED SPARE PARTS LIST	7

WARRANTY & RETURN POLICY

RETURN MERCHANDISE AUTHORIZATION (RMA) FORM

TWR Lighting, Inc. **HARK**

Enlightened Technology

AA6MDFLEDPO CONTROLLER

APPENDIX

CHASSIS LAYOUT	1309-R
SCHEMATIC LAYOUT	1309-S
PHOTOCELL HOUSING DETAIL	100239 (REV H)
LEDBEAON2 ASSEMBLY	100761 (REV C)
OL1VLED2 (L810 OBSTRUCTION LIGHT).....	100656 (REV E)

TWR Lighting, Inc. HARK[®]

Enlightened Technology[®]

AA6MDFLEDPO CONTROLLER

1.0 GENERAL INFORMATION

The flash rate of the LED beacons is 30 per minute. The beacons flash synchronized to one another. The sidelights burn steady.

A by-pass switch (SW1) allows the controller to be turned on during daylight hours without covering the photocell. This is particularly helpful since the controller can be mounted indoors while the photocell is outdoors.

The photocell is the three (3) blade, twist to lock, type.

Power supplied to the controller shall be 120/240V, three (3) wire, single phase.

TWR Lighting, Inc. **HARK**

Enlightened Technology

AA6MDFLEDPO CONTROLLER

2.0 INSTALLATION

2.1 MOUNTING THE CONTROL CABINET

(Refer to Drawing 1309-R)

2.1.1 The power supply control cabinet can be located at the base of the structure, or in an equipment building. Mounting footprints are shown on Drawing 1309-R. Power wiring to the control cabinet should be in accordance with local methods and the National Electrical Codes (NEC).

2.1.2 If the control cabinet is mounted inside an equipment building, the photocell should be mounted vertically on ½” conduit outside the building above the eaves facing north. Wiring from the photocell socket to the control cabinet should consist of one (1) each: red, black, and white wire. The white wire is connected to the socket terminal marked “Li,” and the red wire is connected to the socket terminal marked “Lo.” As above, the photocell should be positioned so that it does not “see” ambient light, which would prevent it from switching to the nightmode.

2.1.3 If the control cabinet is mounted outside an equipment building, the photocell should be mounted vertically on ½” conduit so the photocell is above the control cabinet. Care must be taken to assure that the photocell does not “see” any ambient light, which would prevent it from switching into the nightmode. The photocell wiring is the same as in 2.1.2.

2.2 PHOTOCELL INSTALLATION

(Refer to Drawing 1309-R)

2.2.1 The wiring from the photocell, the service breaker, the red LED beacons, and the sidelights should enter the control cabinet through water-tight connectors in the bottom of the cabinet. Inside the cabinet, the connections will be made on terminal blocks and circuit breakers located at the bottom of the chassis. These connections are made as follows:

- a) Connect the **BLACK** wire from the photocell to the terminal block TB2 marked “L2.”

TWR Lighting, Inc. **MARK**[®]

Enlightened Technology[®]

AA6MDFLEDPO CONTROLLER

- b) Connect the **RED** wire from the photocell to the terminal block TB2 marked “SSR.”
- c) Connect the **WHITE** wire from the photocell to the terminal block TB2 marked “N.”

2.3 POWER WIRING

(Refer to Drawing 1309-R)

- 2.3.1 Power wiring to the control cabinet should be in accordance with local methods and the NEC.
- 2.3.2 Circuit breaker needs to be rated a two (2) pole common trip rated at 10 amps.
- 2.3.3 Connect incoming 120V AC “Hot #1” to terminal block TB1, marked “L1.”
- 2.3.4 Connect incoming 120V AC “Hot #2” to terminal block TB1, marked “L2.”
- 2.3.5 Connect neutral wire(s) to one (1) of the terminal blocks on TB1, marked “N.”
- 2.3.6 Connect the AC ground to the grounding lug located to the left of TB2.

2.4 RED BEACON AND SIDELIGHT WIRING

(Refer to Drawing 1309-R)

- 2.4.1 Connect the **FIRST** wire from LED Beacon #1 to the Circuit Breaker marked “B1.”
- 2.4.2 Connect the **SECOND** wire from LED Beacon #2 to the Circuit Breaker marked “B2.”
- 2.4.3 Connect the **THIRD** wire from LED Beacon #3 to the Circuit Breaker marked “B3.”
- 2.4.4 Connect the **FOURTH** wire from LED Beacon #4 to the Circuit Breaker marked “B4.”

TWR Lighting, Inc. HARK[®]

Enlightened Technology[®]

AA6MDFLEDPO CONTROLLER

- 2.4.5 Connect the **FIFTH** wire from LED Beacon #5 to the Circuit Breaker marked “B5.”
- 2.4.6 Connect the **SIXTH** wire from LED Beacon #6 to the Circuit Breaker marked “B6.”
- 2.4.7 Connect the **FIRST** wire from LED sidelight group #1 to the Circuit Breaker marked “S1.”
- 2.4.8 Connect the **SECOND** wire from LED sidelight group #2 to the Circuit Breaker marked “S2.”
- 2.4.9 Connect the **THIRD** wire from LED sidelight group #3 to the Circuit Breaker marked “S3.”
- 2.4.10 Connect the **NEUTRAL** wire(s) to one (1) of the terminals on TB1, marked “N.”

TWR Lighting, Inc. HARK[®]

Enlightened Technology[®]

AA6MDFLEDPO CONTROLLER

3.0 THEORY OF OPERATION

3.1 POWER SUPPLY

120/240V AC enters the controller from the Circuit Breaker panel. Lines “L1” and “L2” sit at the PRD, waiting to be switched. When the 6390-FAA photocell is activated, line “SSR” energizes the coil of the PRD. This also can be accomplished by using the photocell by-pass switch (SW1).

3.2 LED SIDELIGHTS

Line LDS is sent to the Circuit Breakers marked “S1,” “S2,” and “S3,” which power the LED sidelight circuits.

3.3 LED BEACONS

Line LDB is sent to the coil of the motorized flasher and the six (6) sets of contacts on the 30S8 motorized flasher. When the controller is turned on, these contacts will deliver the voltage to Circuit Breakers “B1 – B6,” which will operate the LED Beacons at 30 flashes per minute.

TWR Lighting, Inc. HARK[®]

Enlightened Technology[®]

AA6MDFLEDPO CONTROLLER

4.0 MAINTENANCE

4.1 RED OBSTRUCTION LIGHTING

No scheduled maintenance is required. Perform on an “as needed” basis only.

TOOLS REQUIRED: NONE

4.2 L-864 LED BEACON REPLACEMENT

No scheduled maintenance is required. Perform on an “as needed” basis only.

4.3 L-864 CONTROLLER

No scheduled maintenance is required. Perform on an “as needed” basis only.

4.4 PHOTOCELL

The photocell is a sealed unit. No maintenance is needed or required, other than replacement as necessary.

TWR Lighting, Inc. **HARK** *Enlightened Technology*

AA6MDFLEDPO CONTROLLER

5.0 MAJOR COMPONENTS PARTS LIST

QTY	PART NUMBER	DESCRIPTION
1	6390-FAA	120-240V AC PHOTOCELL
1	30S8	MOTOR FLASHER
1	PRD7AGO	MECHANICAL LOAD CONTACTOR (PRD)
9	S261D1	10 amp CIRCUIT BREAKERS (S1 – S3 and B1 – B6)
2	MOV524V15	METAL OXIDE VARISTOR (MOV1 and MOV2)
2	8WA1808	END SECTION
1	SSPIGTAIL	20' PHOTOCELL PIGTAIL
1	STJ01002	SW1 SWITCH
7	8WA1204	TB1 and TB2 TERMINAL BLOCK
14	8WA8-848-2AY	TERMINAL STRIP, TB1 and TB2

TWR Lighting, Inc. HARK[®]

Enlightened Technology[®]

AA6MDFLEDPO CONTROLLER

6.0 SUGGESTED SPARE PARTS LIST

QTY	PART NUMBER	DESCRIPTION
1	6390-FAA	120-240V AC PHOTOCELL

TWR Lighting[®], Inc. **HARK[®]**

Enlightened Technology[®]

AA6MDFLEDPO CONTROLLER

Warranty & Return Policy

TWR Lighting[®], Inc. (“TWR[®]”) warrants its products (other than “LED Product”) against defects in design, material (excluding incandescent bulbs) and workmanship for a period ending on the earlier of two (2) years from the date of shipment or one (1) year from the date of installation.

TWR Lighting[®], Inc. (“TWR[®]”) warrants its “LED Product” against defects in design, material and workmanship for a period of five (5) years from the date of shipment. TWR[®], at its sole option, will, itself, or through others, repair, replace or refund the purchase price paid for “LED Product” that TWR[®] verifies as being inoperable due to original design, material, or workmanship. All warranty replacement “LED Product” is warranted only for the remainder of the original warranty of the “LED Product” replaced. Replacement “LED Product” will be equivalent in function, but not necessarily identical, to the replaced “LED Product.”

TWR Lighting[®], Inc. (“TWR[®]”) warrants its “LED Product” against light degradation for a period of five (5) years from the date of installation. TWR[®], at its sole option, will, itself, or through others, repair, replace, or refund the purchase price paid for “LED Product” that TWR[®] verifies as failing to meet 75% of the minimum intensity requirements as defined in the FAA Advisory Circular 150/5345-43G dated 09/26/12. All warranty replacement “LED Product” is warranted only for the remainder of the original warranty of the “LED Product” replaced. Replacement “LED Product” will be equivalent in function, but not necessarily identical, to the replaced “LED Product.”

Replacement parts (other than “LED Product”) are warranted for 90 days from the date of shipment.

Conditions not covered by this Warranty, or which might void this Warranty are as follows:

- x Improper Installation or Operation
- x Misuse
- x Abuse
- x Unauthorized or Improper Repair or Alteration
- x Accident or Negligence in Use, Storage, Transportation, or Handling
- x Any Acts of God or Nature
- x **Non-OEM Parts**

The use of Non-OEM parts or modifications to original equipment design will void the manufacturer warranty and could invalidate the assurance of complying with FAA requirements as published in Advisory Circular 150/5345-43.

TWR Lighting, Inc. **HARK** *Enlightened Technology*

AA6MDFLEDPO CONTROLLER

Warranty & Return Policy (continued)

Field Service – Labor, Travel, and Tower Climb are not covered under warranty. Customer shall be obligated to pay for all incurred charges. An extensive network of certified and insured Service Representatives is available if requested.

Return Terms – You must first contact our Customer Service Department at **713-973-6905** to acquire a Return Merchandise Authorization (RMA) number in order to return the product(s). Please have the following information available when requesting an RMA number:

- x The contact name and phone number of the tower owner
- x The contact name and phone number of the contractor
- x The site name and number
- x The part number(s)
- x The serial number(s) (if any)
- x A description of the problem
- x The billing information
- x The Ship To address

This RMA number must be clearly visible on the outside of the box. If the RMA number is not clearly labeled on the outside of the box, your shipment will be refused. Please ensure the material you are returning is packaged carefully. **The warranty is null and void if the product(s) are damaged in the return shipment.**

All RMAs must be received by TWR LIGHTING®, INC., 10810 W. LITTLE YORK RD., #130, HOUSTON, TX 77041-4051, within 30 days of issuance.

Upon full compliance with the Return Terms, TWR® will replace, repair and return, or credit product(s) returned by the customer. It is TWR®'s sole discretion to determine the disposition of the returned item(s).

TWR Lighting, Inc. **HARK**[®]

Enlightened Technology[®]

AA6MDFLEDPO CONTROLLER

Warranty & Return Policy (continued)

Replacements – Replacement part(s) will be shipped and billed to the customer for product(s) considered as Warranty, pending return of defective product(s). When available, a certified reconditioned part is shipped as warranty replacement with a Return Merchandise Authorization (RMA) number attached. Upon receipt of returned product(s), inspection, testing, and evaluation will be performed to determine the cause of defect. The customer is then notified of the determination of the testing.

- x Product(s) that is deemed defective and/or unrepairable and covered under warranty - a credit will be issued to the customer's account.
- x Product(s) found to have no defect will be subject to a **\$75.00 per hour testing charge (1 hour minimum), which will be invoiced to the customer.** At this time the customer may decide to have the tested part(s) returned and is responsible for the return charges.
- x Product(s) under warranty, which the customer does not wish returned, the customer will be issued a credit against the replacement invoice.

Repair & Return – A Return Merchandise Authorization (RMA) will be issued for all part(s) returned to TWR[®] for repair. Upon receipt of returned product(s), inspection, testing, and evaluation will be performed to determine the cause of defect. The customer is then notified of the determination of the testing. If the returned part(s) is deemed unrepairable, or the returned part(s) is found to have no defect, the customer will be subject to a **\$75.00 per hour testing charge (1 hour minimum), which will be invoiced to the customer.** Should the returned parts be determined to be repairable, a written estimated cost of repair will be sent to the customer for their written approval prior to any work being performed. In order to have the tested part(s) repaired and/or returned, the customer must issue a purchase order and is responsible for the return shipping charges.

Return to Stock – Any order that is returned to TWR[®] for part(s) ordered incorrectly by the customer, or unneeded upon receipt, the customer is required to pay a **20% restocking fee.** A credit will be issued once it is determined that the Return Terms are met.

Credits – Credits are issued once it is determined that all of the Warranty and Return Terms are met. All credits are processed on Fridays. In the event a Friday falls on a Holiday, the credit will be issued on the following Friday.

Freight – All warranty replacement part(s) will be shipped via ground delivery and paid for by TWR[®]. Delivery other than ground is the responsibility of the customer.

TWR Lighting, Inc. **HARK**[®]

Enlightened Technology[®]

AA6MDFLEDPO CONTROLLER

Warranty & Return Policy (continued)

REMEDIES UNDER THIS WARRANTY ARE LIMITED TO PROVISIONS OF REPLACEMENT PARTS AND REPAIRS AS SPECIFICALLY PROVIDED. IN NO EVENT SHALL TWR[®] BE LIABLE FOR ANY OTHER LOSSES, DAMAGES, COSTS, OR EXPENSES INCURRED BY THE CUSTOMER, INCLUDING, BUT NOT LIMITED TO, LOSS FROM FAILURE OF THE PRODUCT(S) TO OPERATE FOR ANY TIME, AND ALL OTHER DIRECT, INDIRECT, SPECIAL, INCIDENTAL, OR CONSEQUENTIAL DAMAGES, INCLUDING ALL PERSONAL INJURY OR PROPERTY DAMAGE DUE TO ALLEGED NEGLIGENCE, OR ANY OTHER LEGAL THEORY WHATSOEVER. THIS WARRANTY IS MADE BY TWR[®] EXPRESSLY IN LIEU OF ALL OTHER WARRANTIES, WHETHER EXPRESSED OR IMPLIED. WITHOUT LIMITING THE GENERALITY OF THE FORGOING, TWR[®] MAKES NO WARRANTY OF MERCHANTABILITY OR FITNESS OF THE PRODUCT(S) FOR ANY PARTICULAR PURPOSE. TWR[®] EXPRESSLY DISCLAIMS ALL OTHER WARRANTIES.

TWR Lighting, Inc. HARK[®]

Enlightened Technology[®]

AA6MDFLEDPO CONTROLLER

RETURN MERCHANDISE AUTHORIZATION (RMA) FORM

RMA#: _____ **DATE:** _____

CUSTOMER: _____

CONTACT: _____ **PHONE NO.:** _____

ITEM DESCRIPTION (PART NO.): _____

MODEL NO.: _____ **SERIAL NO.:** _____

ORIGINAL TWR INVOICE NO.: _____ **DATED:** _____

DESCRIPTION OF PROBLEM: _____

SIGNED _____ **DATE NEEDED** _____

RETURN ADDRESS: _____

PLEASE RETURN PRODUCT TO: 10810 W. LITTLE YORK RD., #130 HOUSTON, TX 77041-4051

TWR Lighting, Inc. HARK[®]

Enlightened Technology[®]

AA6MDFLEDPO CONTROLLER

RETURN MERCHANDISE AUTHORIZATION (RMA) FORM

RMA#: _____ **DATE:** _____

CUSTOMER: _____

CONTACT: _____ **PHONE NO.:** _____

ITEM DESCRIPTION (PART NO.): _____

MODEL NO.: _____ **SERIAL NO.:** _____

ORIGINAL TWR INVOICE NO.: _____ **DATED:** _____

DESCRIPTION OF PROBLEM: _____

SIGNED _____ **DATE NEEDED** _____

RETURN ADDRESS: _____

PLEASE RETURN PRODUCT TO: 10810 W. LITTLE YORK RD., #130 HOUSTON, TX 77041-4051

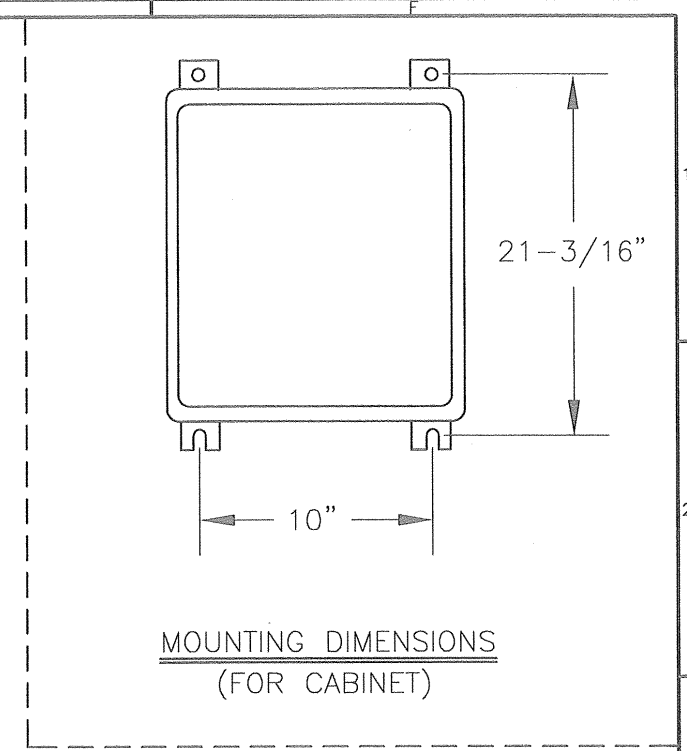
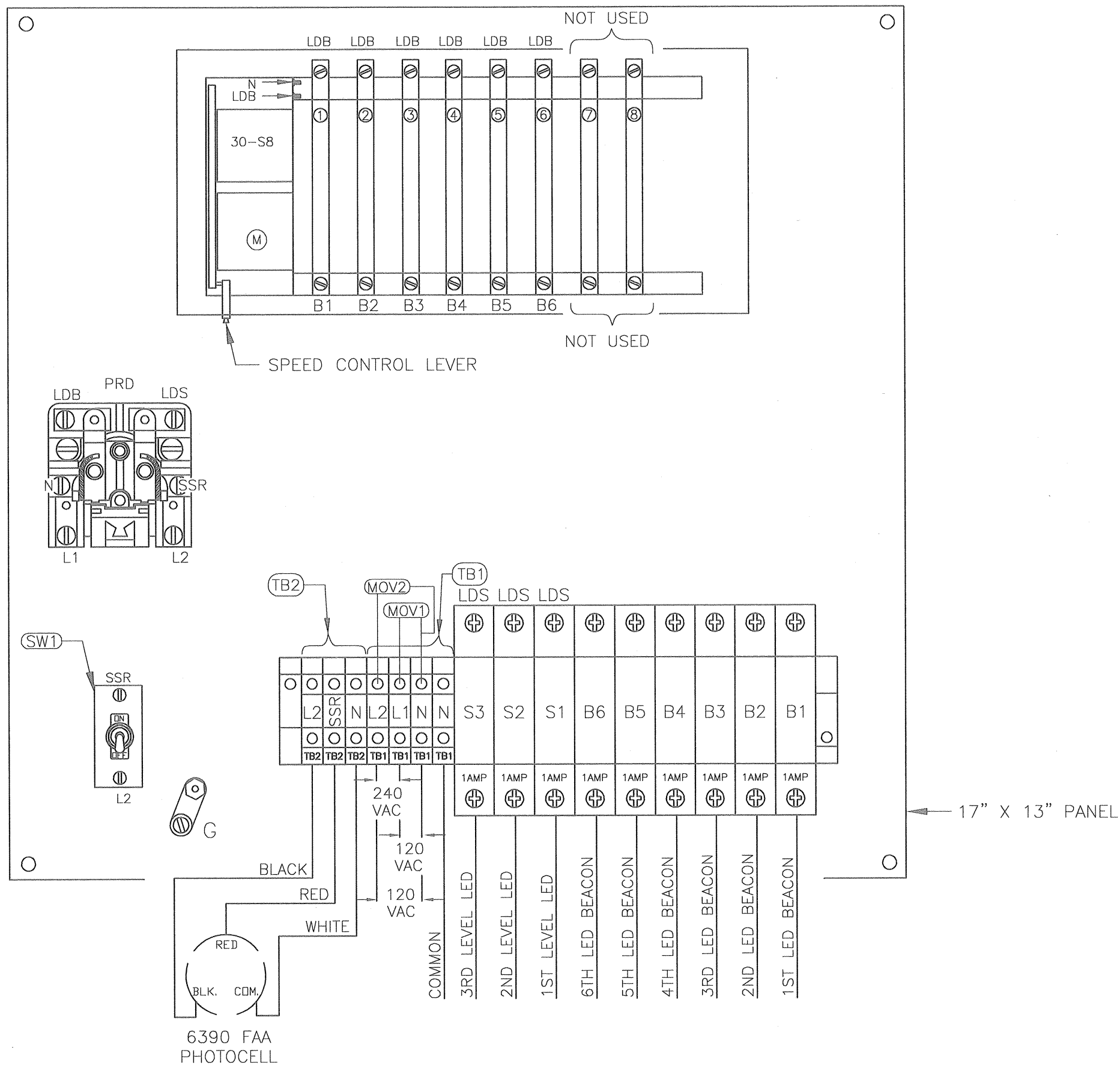

NOTES:
 1. WIRES ARE CONNECTED LETTER TO LETTER. (EXAMPLE) N TO N TO N.

120/240VAC 50/60 Hz

AA6MDFLEDPO CONTROLLER (PANEL ONLY)

<small>PROD DEPT</small>		<small>SHEET SIZE</small>	<small>SHEET QTY.</small>
<small>SERV DEPT</small>		B	1 OF 1
<small>ENGINEER</small>			
<small>DRAWN BY</small>	J. ZAMORANO	<small>SCALE</small>	N.T.S.
<small>DATE</small>	10/05/2015	<small>DWG. NO.</small>	1309-R

The use of non OEM parts or modifications to original equipment design will void the manufacturer warranty and could invalidate the assurance of compliance with FAA requirements as published in Advisory Circular 150/5345-43. NOTICE: The drawings and photographic images contained herein are the sole property of TWR Lighting, Inc. All information contained herein that is not generally known shall be considered confidential except to the extent the information has been previously established. The drawings and photographic images contained herein may not be reproduced, copied or used as the basis for manufacture or sale or promotion or any other purpose without the expressed written permission of TWR Lighting, Inc.

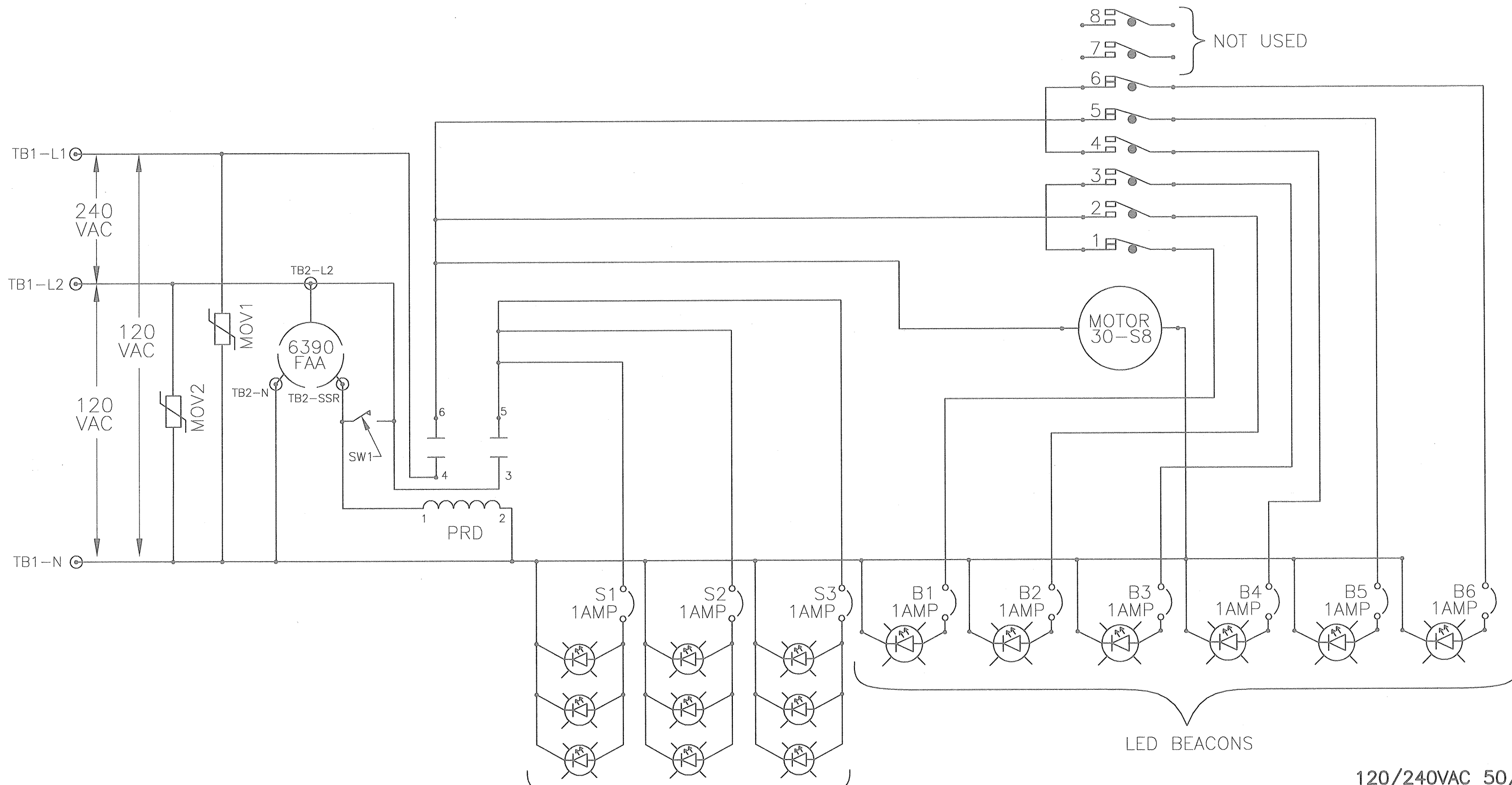

LED SIDELIGHTS

LED BEACONS

120/240VAC 50/60 Hz

AA6MDFLEDPO SCHEMATIC LAYOUT

PROD DEPT <i>[Signature]</i>	TWR Lighting, Inc. <i>Enlightened Technology</i> WARK		
SERV DEPT C			
ENGINEER			
DRAWN BY J.ZAMORANO	SHEET SIZE B	SHEET QTY. 1 OF 1	
DATE 10/07/2015	SCALE N.T.S.	DWG. NO. 1309-S	

NOTICE: The drawings and photographic images contained herein are the sole property of TWR Lighting, Inc. All information contained herein that is not generally known shall be considered confidential except to the extent the information has been previously established. The drawings and photographic images contained herein may not be reproduced, copied or used as the basis for manufacture or sale or promotion or any other purpose without the expressed written permission of TWR Lighting, Inc.

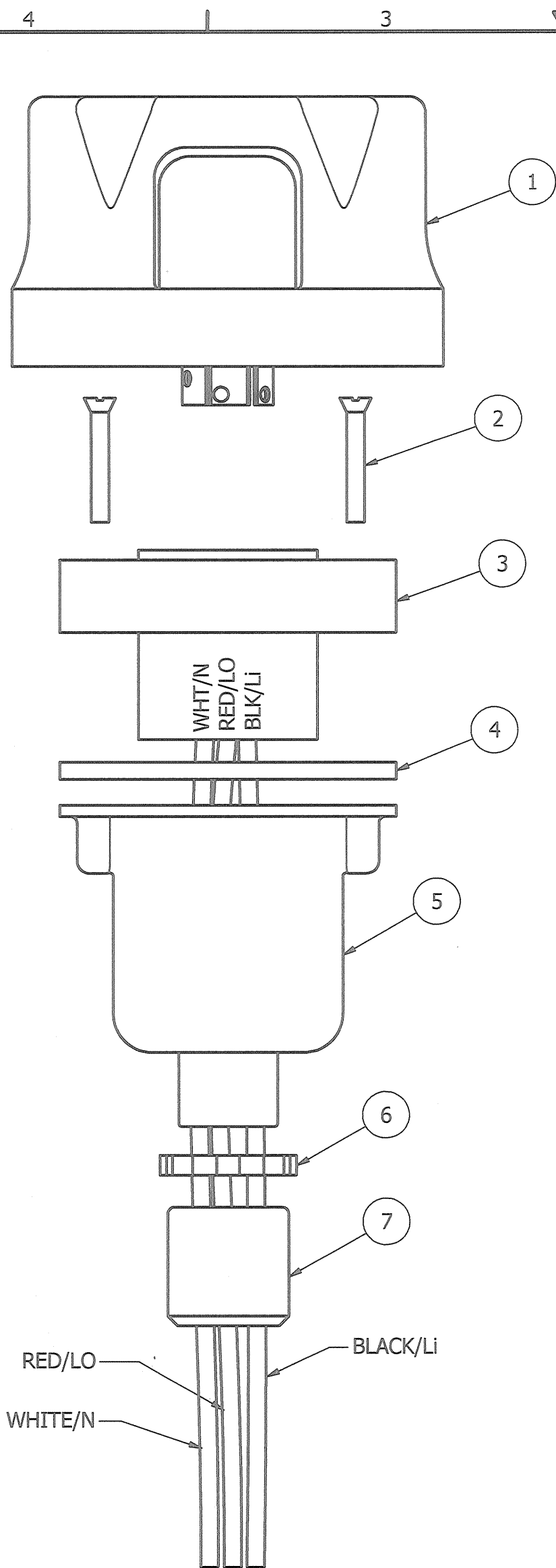

EXPLODED VIEW

PARTS LIST		
ITEM	QTY	PART NUMBER
1	1	PHOTOCELL
2	2	6-32 x 1" SCREW
3	1	RECEPTACLE SOCKET
4	1	RECEPTACLE GASKET
5	1	RECEPTACLE HOUSING
6	1	1/2" CONDUIT LOCKNUT
7	1	3/4" TO 1/2" REDUCER

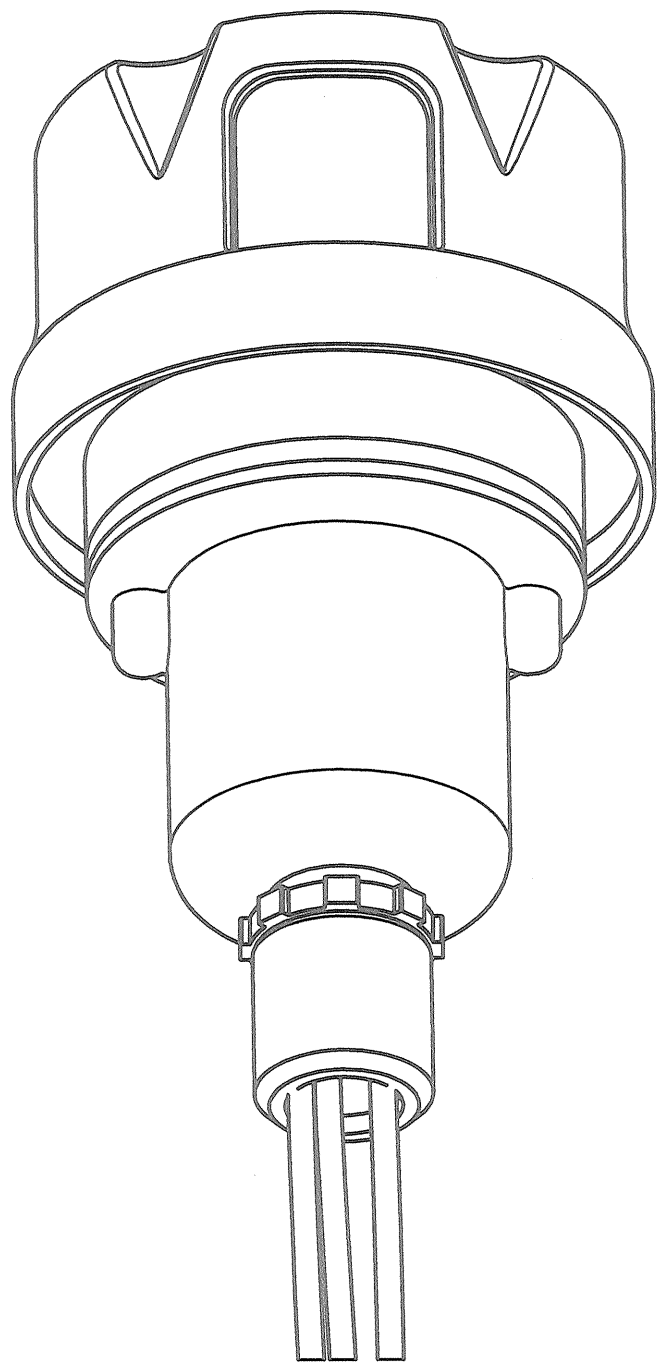

ASSEMBLY

NOTES:

- ITEM #7 CAN BE USED TO REDUCE 3/4" CONDUIT TO 1/2" CONDUIT AT THE HOUSING OR AT THE CONTROLLER ITSELF.
- IF ADDITIONAL WIRE IS REQUIRED OVER THE FACTORY 20', USE THE FOLLOWING CHART.
 21' TO 300' - 16 AWG TFFN
 301' TO 500' - 14 AWG TFFN

PHOTOCELL HOUSING DETAIL

PROD. DEPT. *[Signature]*
 SERV. DEPT. **TWR Lighting, Inc. HARK**
 ENGINEER *[Signature]*
Enlightened Technology®

DRAWN BY	vhernandez	SHEET SIZE	B	SHEET QTY.	1 OF 1
DATE	10/18/1995	SCALE	1/1	DWG. NO.	100239i

DATE	REV	AUTHOR	DESCRIPTION
02/03/2015	H	JZAMORANO	UPDATED NOTES

The use of non-OEM parts or modifications to original equipment design will void the manufacturer warranty and could invalidate the assurance of complying with FAA requirements as published in Advisory Circular 150/5345-43.
 NOTICE: The drawings and photographic images contained herein are the sole property of TWR Lighting, Inc. All information contained herein that is not generally known shall be considered confidential except to the extent the information has been previously established. The drawings and photographic images contained herein may not be reproduced, copied or used as the basis for manufacture or sale or promotion or any other purpose without the expressed written permission of TWR Lighting, Inc.

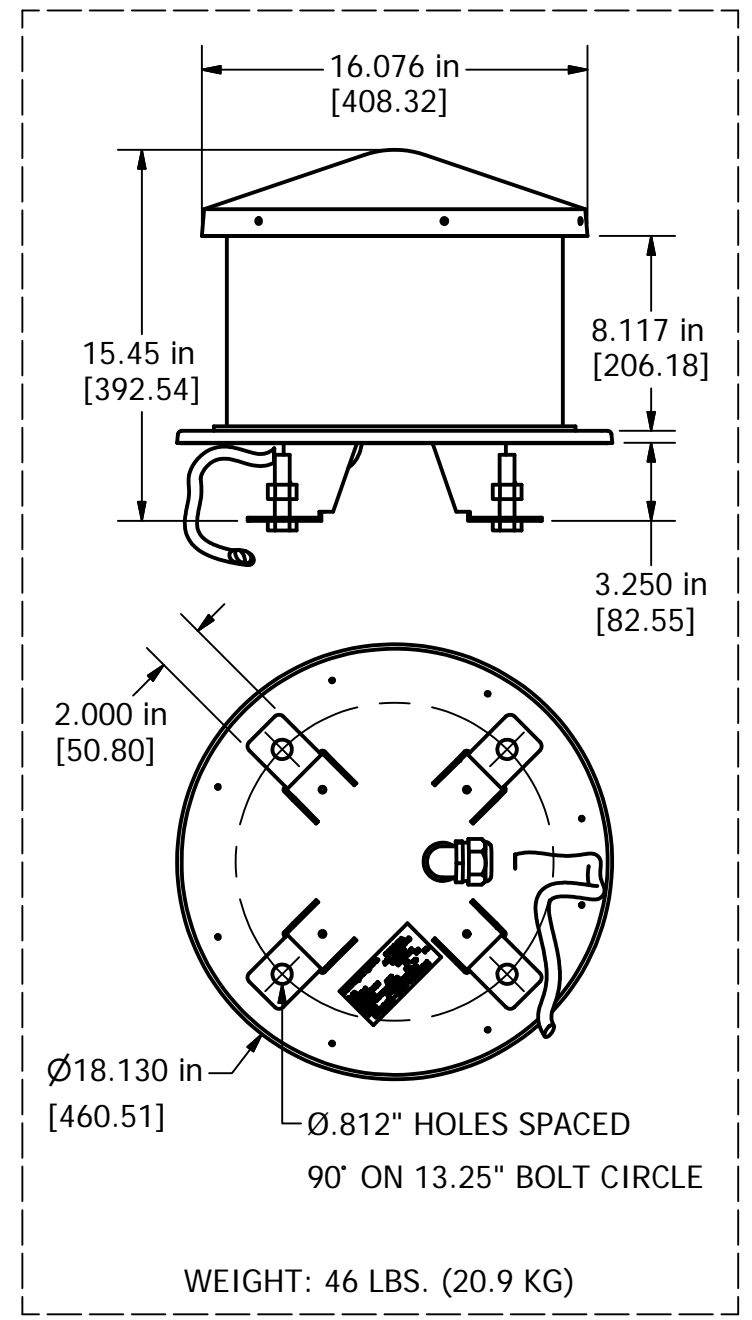
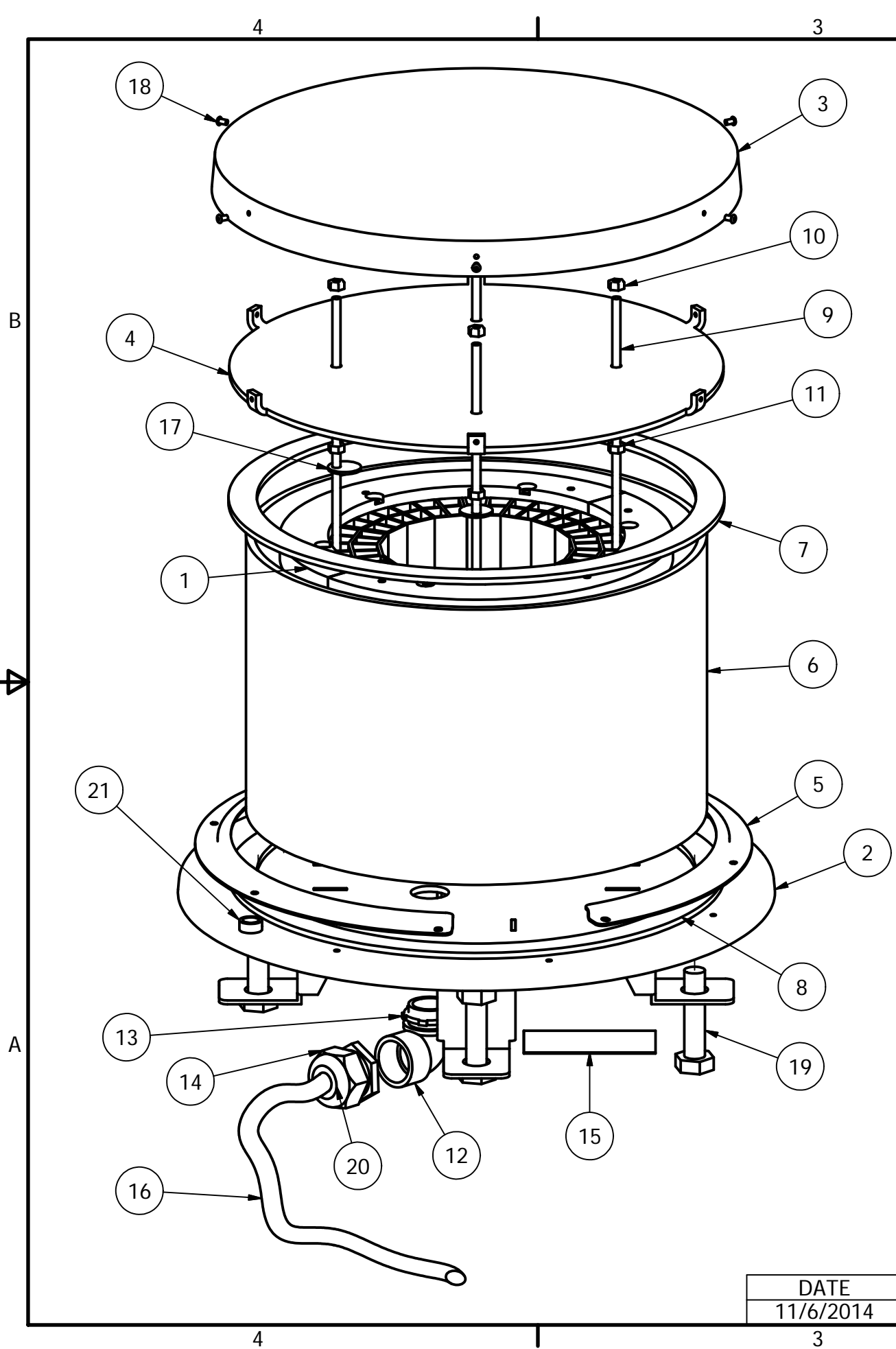

Parts List				
ITEM	QTY	PART NUMBER	DESCRIPTION	
1	1	LEDLITEENG2	ORGA L-864 LED LIGHT ENGINE 120/240VAC	
2	1	100672	LED BEACON BASE PLATE	
3	1	100344	CAP DUAL BEACON	
4	1	100673	LED BEACON LID PLATE	
5	2	100337	LENS RETAINER RING	
6	1	STLDBCTUBE2	CLEAR ACRYLIC TUBE	
7	1	STBEAGSK4	GASKET NEOPRENE 13 1/8 X 15 OD X	
8	1	STBEAGSKT	GASKET NEOPRENE 13 1/4 X 15	
9	4	100727	14-20 X 9.875" DE 304 S.S. ORG	
10	4	1420SSNUTN	1/4-20 NUT W/NYLON INSERT 304	
11	4	1420NUT	1/4-20 NUT 304 S/S	
12	1	EL190S	1" 90 DEGREE SHORT ELBOW GALV.	
13	1	A315	1" CONDUIT LOCKNUT GALV.	
14	1	CC-NPT34-G	3/4" NPT CORD CONNECTOR .500"	
15	1	STCONLAB2	100223 PRODUCT LABEL	
16	21'	CSO14-3	S.O. CORD 14AWG/3 CONDUCTOR	
17	2	100606M	LED LIGHT ENGINE TIE DOWN WASH	
18	6	18PRSS-2	1/8 X .400 SS POP RIVET #44	
19	4	58X112	5/8 X 1-1/2 HEX BOLT	
20	1	RE32	1" TO 3/4" REDUCER, GALV.	
21	1	2-10000	CIRCULAR SPIRIT LEVEL	
*	22	8	1032X38PHW	10-32X3/8 PHILLS HD CAPTIVE SCREW

* = ITEMS NOT SHOWN

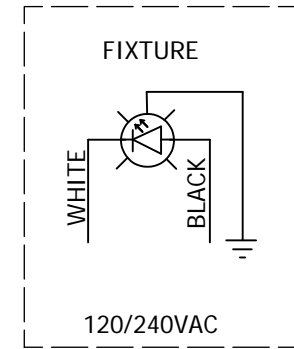

* GROUND WIRE MUST BE CONNECTED TO PROPERLY PROTECT POWER SUPPLY. FAILURE TO GROUND WILL VOID ALL WARRANTIES.

DATE	AUTHOR	REV	DESCRIPTION
11/6/2014	JZamorano	C	UPDATED BOM

DRAWN VHernandez	9/4/2007	TWR Lighting, Inc. PARK <i>Enlightened Technology®</i>	
CHECKED			
QA		TITLE	
MFG		LED BEACON2 ASSEMBLY	
APPROVED		SIZE B	DWG NO 100761
		SCALE 1/4	REV C
		SHEET 1 OF 1	

4

3

2

1

Parts List

ITEM	QTY	PART NUMBER	DESCRIPTION
1	1	OL1VLED2	L810 OBSTRUCTION LIGHT
* 1.1	1	100588_RE	OL 6LED BASE PLATE
* 1.2	1	100591	OL 6LED STAR DISK
* 1.3	1	100680	OL1/2 SERIAL # LABEL
* 1.4	1	A10290	5/32" ID RUBBER GROMMET
* 1.5	6	STD05008	LED EMITTER
* 1.6	1	OLG	OL GASKET
* 1.7	1	AP100846	SIDELIGHT LENS CLEAR ACYRLIC
* 1.8	1	106V	LENS HOLDER RING
* 1.9	6	STE01-047	LED VERTICAL PCB
* 1.10	16	18PRSS	1/8 X .45 SS POP RIVET
* 1.11	1	PS90-260/24	POWER SUPPLY
* 1.12	1	20RED	#20AWG RED BELDON WIRE
* 1.13	2	WIRENUTBLU	BLUE WIRE NUT
2	2	HC255SS	SIDELIGHT LATCH
3	1	7X7SS	1/16 HOL 7X7 S.S. WIRE
4	2	12V245	OL LENS CLIP
5	1	105V	SINGLE SIDELIGHT BODY
6	2	832X14PH	8-32 X 1/4 PH SS SLOT SCREW
7	2	A1A	STAKON CRIMP
8	1	A314	3/4" CONDUIT LOCKNUT GALV.

* = ITEMS NOT SHOWN

B

B

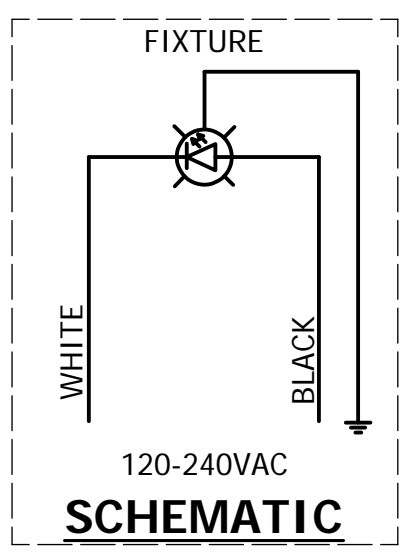
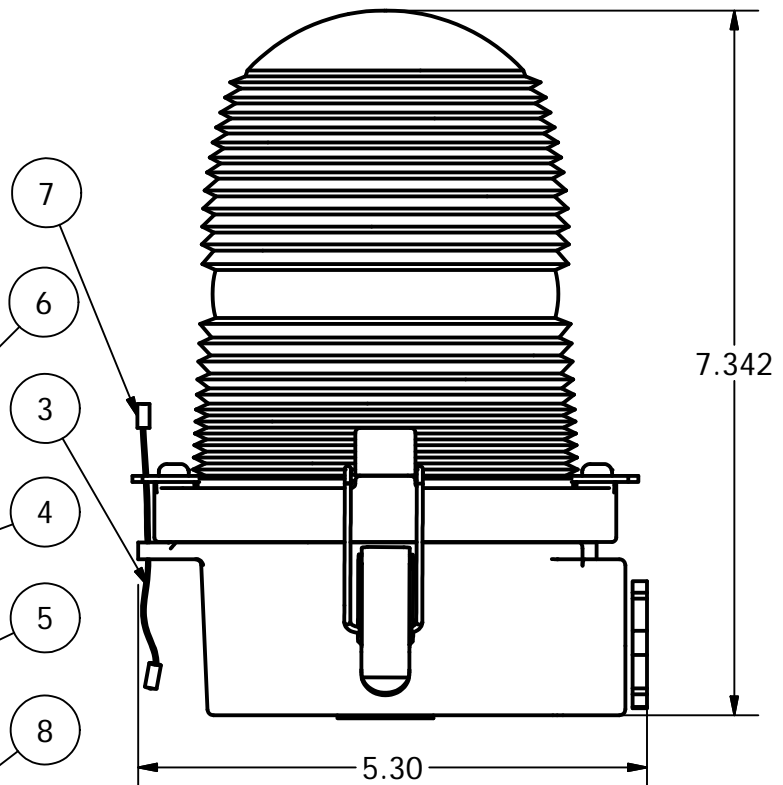
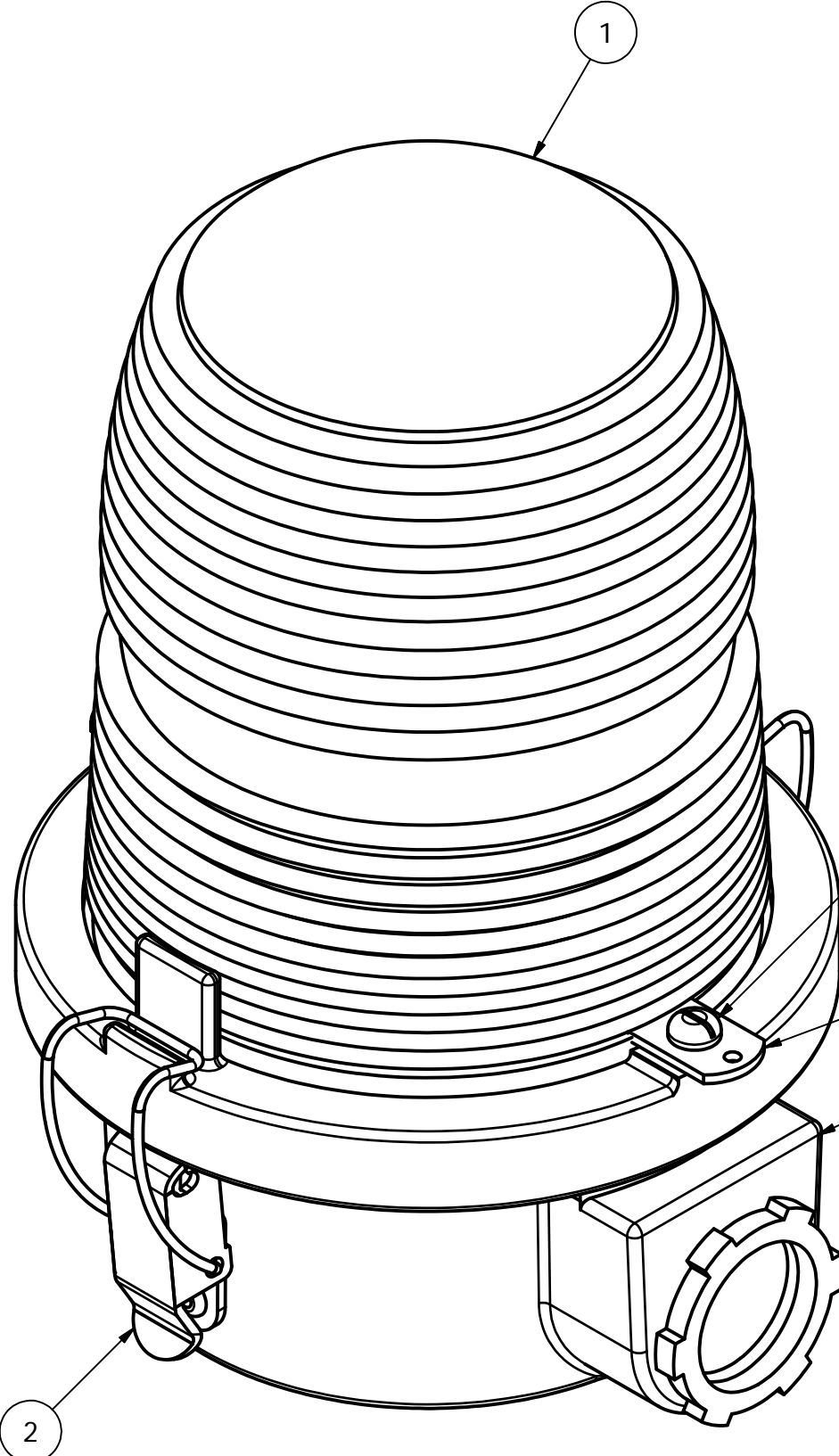

* GROUND WIRE MUST BE CONNECTED TO PROPERLY PROTECT POWER SUPPLY. FAILURE TO GROUND WILL VOID ALL WARRANTIES.

A

A

DRAWN	gsebek	8/18/2004
CHECKED		
QA		
MFG		
APPROVED		

TWR Lighting, Inc. *Enlightened Technology* **WARK**

TITLE: OL1VLED2 120-240VAC FAA-OL16LED (L810 OBSTRUCTION LIGHT)

SIZE: B DWG NO: 100656i REV: E

SCALE: SHEET 1 OF 1

DATE	REV	AUTHOR	DESCRIPTION
11/07/14	E	JZAMORANO	REM. WIRE CONNECT

4

3

2

1