

TWR Lighting, Inc. HARK[®]

Enlightened Technology[®]

4300 WINDFERN RD #100 HOUSTON TX 77041-8943
VOICE (713) 973-6905 FAX (713) 973-9352
web: www.twrlighting.com

IMPORTANT!!!

PLEASE TAKE THE TIME TO FILL OUT THIS FORM COMPLETELY. FILE IT IN A SAFE PLACE. IN THE EVENT YOU EXPERIENCE PROBLEMS WITH OR HAVE QUESTIONS CONCERNING YOUR CONTROLLER, THE FOLLOWING INFORMATION IS NECESSARY TO OBTAIN PROPER SERVICE AND PARTS.

MODEL # AA3TSS

SERIAL # _____

PURCHASE DATE _____

PURCHASED FROM _____

TWR Lighting, Inc. HARK®

Enlightened Technology®

AA3-TSS CONTROLLER

TABLE OF CONTENTS

1.0	GENERAL INFORMATION.....	1
2.0	INSTALLATION	2
2.1	MOUNTING THE CONTROL CABINET.....	2
2.2	EXTERNAL PHOTCELL WIRING.....	3
2.3	POWER WIRING.....	3
2.4	RED BEACON & SIDELIGHT WIRING.....	4
3.0	THEORY OF OPERATION	5
3.1	POWER SUPPLY.....	5
3.2	SIDELIGHTS	5
3.3	BEACONS.....	5
4.0	MAINTENANCE GUIDE.....	6
4.1	RED OBSTRUCTION LIGHTING.....	6
4.2	L-864 LAMP REPLACEMENT	6
4.3	L-810 LAMP REPLACEMENT	6
4.4	L-864 CONTROLLER.....	7
4.5	PHOTOCELL.....	7
5.0	MAJOR COMPONENTS PARTS LIST	8
6.0	SUGGESTED SPARE PARTS LIST.....	9

WARRANTY & RETURN POLICY

RETURN MERCHANDISE AUTHORIZATION (RMA) FORM

TWR Lighting, Inc. HARK[®]

Enlightened Technology[®]

AA3-TSS CONTROLLER

APPENDIX

CHASSIS COMPONENT LAYOUT	1098-R (REV B)
SCHEMATIC LAYOUT	1098-S (REV C)
TROUBLESHOOTING FLOW CHART	1098-F (REV A)
TOWER LIGHTING KITS 351' TO 400'	261-31 (REV E)
TOWER LIGHTING KITS 401' TO 500'	261-32 (REV D)
L-810 OL-1 SINGLE OBSTRUCTION LIGHT DETAIL.....	279-OL (REV C)
L-810 OL-1 WIRING DETAIL	274-S (REV A)
L-864 FB 300 MM BEACON DETAIL.....	275-B (REV E)
L-864 FB 300 MM WIRING DETAIL	273-B
JUNCTION AND STRAIN RELIEF BOXES.....	100089 (REV A)
WRAPLOCK FASTENING DETAIL.....	100984

TWR Lighting, Inc. HARK[®]

Enlightened Technology[®]

AA3-TSS CONTROLLER

1.0 GENERAL INFORMATION

The TWR Lighting[®], Inc. (TWR[®]) Model AA3-TSS Controller is for towers 700' to 1050' above ground level. Beacons should be placed at top, 2/3, and 1/3 intervals with respect to overall tower height. Obstruction lights should be placed at 5/6, 1/3, and 1/6 intervals.

The flash rate of the beacons is thirty (30) per minute. The beacons flash synchronized to one another. The sidelights burn steady.

A by-pass switch allows the controller to be turned on during daylight hours without covering the photocell. This is particularly helpful since the controller can be mounted indoors while the photocell is outdoors.

Each beacon requires (2) 620 watt or (2) 700 watt 120V bulbs. TWR[®] recommends that you use only these bulbs. Each sidelight requires one (1), 120V bulb.

The photocell is the three (3) blade, twist to lock, type.

Power supplied to the controller shall be 120/240 volts wire single phase.

The controller housing is rated at NEMA 4X. It is suitable for indoor or outdoor mounting.

AA3-TSS CONTROLLER

2.0 INSTALLATION

2.1 MOUNTING THE CONTROL CABINET

(Refer to Drawing 1098-R)

The power supply control cabinet can be located at the base of the structure or in an equipment building. Mounting footprints are shown on drawing 1098-R. Power wiring to the control cabinet should be in accordance with local methods and National Electrical Codes (NEC).

2.1.1 If the control cabinet is mounted inside an equipment building, the photocell should be mounted vertically on ½” conduit outside the building above the eaves facing north. Wiring from the photocell socket to the control cabinet should consist of one (1) each, red, black, and white wires. The white wire is connected to the socket terminal marked “N,” the black wire is connected to the socket terminal marked “Li,” and the red wire is connected to the socket terminal marked “Lo.” The photocell should be positioned so that it does not “see” ambient light, which would prevent it from switching to the nightmode.

2.1.2 If the control cabinet is mounted outside an equipment building, the photocell should be mounted vertically on ½” conduit so the photocell is above the control cabinet. Care must be taken to assure that the photocell does not “see” any ambient light that would prevent it from switching into the nightmode. The photocell wiring is the same as in 2.1.1.

The wiring from the photocell, the service breaker, the red incandescent beacon and the sidelights should enter the control cabinet through the watertight connectors in the bottom of the cabinet. Inside the cabinet, the connections will be made on the terminal blocks and circuit breakers located at the bottom of the controller. These connections are made as follows:

AA3-TSS CONTROLLER

2.2 EXTERNAL PHOTOCELL WIRING

(Refer to Drawing 1098-R)

2.2.1 Connect the **BLACK** wire from the photocell to small terminal block TB2 marked "L2."

2.2.2 Connect the **RED** wire from the photocell to small terminal block TB2 marked "SSR."

2.2.3 Connect the **WHITE** wire from the photocell to small terminal block TB2 marked "N."

2.3 POWER WIRING

(Refer to Drawing 1098-R)

2.3.1 Power wiring to the control cabinet should be in accordance with local methods and National Electrical Codes (NEC).

2.3.2 Circuit breaker needs to be a 2 pole common trip rated at 40 amps.

2.3.3 Connect incoming 120V AC "Hot #1" to terminal block TB1 marked "L1."

2.3.4 Connect incoming 120V AC "hot #2" to terminal block TB1 marked "L2."

2.3.5 Connect the neutral wire to one (1) of the terminal blocks on TB1 marked "N."

2.3.6 Connect the AC ground to the aluminum mounting plate.

AA3-TSS CONTROLLER

2.4 RED BEACON & SIDELIGHT WIRING

(Refer to Drawings 1098-R, 261-31, and 261-32)

2.4.1 Connect the **BLACK** wire from Beacon #1 to breaker marked "B1."

2.4.2 Connect the first **BLUE** wire from Beacon #2 to breaker marked "B2."

2.4.3 Connect the second **BLUE** wire from Beacon #3 to breaker marked "B3."

2.4.4 Connect the **RED** and **YELLOW** wires from sidelight group #1 and #2 to the breaker marked "S."

2.4.5 Connect the **Neutral** wire to one of the terminals TB1 marked "N."

AA3-TSS CONTROLLER

3.0 THEORY OF OPERATION

3.1 POWER SUPPLY

120V/240V AC enters the controller from the circuit breaker panel. Lines (L1, L2) sit at the PRD waiting. When the 6390-FAA photocell is activated, line (L2) energizes the coil of the PRD relay. This can also be accomplished by using the photocell by-pass switch.

3.2 SIDELIGHTS

LD4 is sent to the breaker marked "S" which will power the three (3) levels of the sidelights.

3.3 BEACONS

LD1, LD2, and LD3 are sent to the flasher module M1, and the load contractor modules M5, and M6. M1 is a solid-state flasher that operates Beacon #1, and the coils of module M5, and M6, which make the M5, and M6 flash Beacon #2, and Beacon # 3, synchronized with Beacon #1.

AA3-TSS CONTROLLER

4.0 MAINTENANCE GUIDE

4.1 RED OBSTRUCTION LIGHTING

The only required maintenance needed to be performed is replacement of the lamps in the L-864 and L-810 fixtures. Lamps should be replaced after being operated for not more than 75% of the rated life or immediately upon failure as per FAA Advisory Circular 70/7460-1K. By following these instructions, maximum safety and performance can be achieved.

TOOLS REQUIRED: NONE

4.2 L-864 LAMP REPLACEMENT

4.2.1 Loosen the one (1) wing nut on the latch pin so that it can recline.

4.2.2 Open the lens and tilt it back.

4.2.3 To remove each lamp, depress down while rotating the lamp counter-clockwise 90 degrees.

4.2.4 Install the new lamps by depressing down while rotating the lamp clockwise 90 degrees.

4.2.5 Close the lens and let the latch pin drop in the recessed slot.

4.2.6 Tighten the wing nut snug, then 1/4 turn more.

4.3 L-810 LAMP REPLACEMENT

4.3.1 Unclasp the two (2) latches and let the bail recline back.

4.3.2 Lift the lens up and over the lamp, letting the lens hang from the safety cable.

4.3.3 Unscrew the lamp counter-clockwise and remove.

4.3.4 Install the new lamp by screwing the lamp clockwise.

AA3-TSS CONTROLLER

4.3.5 Reinstall the lens; making sure it is seated properly on the base.

4.3.6 Reclasp the two (2) latches.

4.4 L-864 CONTROLLER

No scheduled maintenance is required. Perform on an as needed basis.

4.5 PHOTOCELL

The photocell is a sealed unit. No maintenance is needed or required other than replacement as necessary.

AA3-TSS CONTROLLER

5.0 MAJOR COMPONENTS PARTS LIST

QTY	PART NUMBER	DESCRIPTION
1	6390-FAA (This replaces the 102-FAA photocell)	120-240V AC Photocell
1	PF-250 (This replaces the FS15530T module)	Solid State Flasher
1	B12J2K5	2500 OHM 12W Resistor
2	SF-250 (This replaces the FA155-2 module)	Solid State Load Contractor
1	PM17AY120V	Mechanical Load Contractor PRD
2	S261D20	20 amp Breaker
3	8WA1204	Single Pole Terminal Block

AA3-TSS CONTROLLER

6.0 SUGGESTED SPARE PARTS LIST

QTY	PART NUMBER	DESCRIPTION
1	6390-FAA (This replaces the 102-FAA photocell)	120-240V AC Photocell
1	PF-250 (This replaces the FS15530T module)	Solid State Flasher
1	SF-250 (This replaces the FA155-2 module)	Solid State Load Contractor
2	S261D20	20 amp Breaker

TWR Lighting[®], Inc. HARK[®]

Enlightened Technology[®]

AA3-TSS CONTROLLER

Warranty & Return Policy

TWR Lighting[®], Inc. (“TWR[®]”) warrants its products (other than “LED Product”) against defects in design, material (excluding incandescent bulbs) and workmanship for a period ending on the earlier of two (2) years from the date of shipment or one (1) year from the date of installation.

TWR Lighting[®], Inc. (“TWR[®]”) warrants its “LED Product” against defects in design, material and workmanship for a period of five (5) years from the date of shipment. TWR[®], at its sole option, will, itself, or through others, repair, replace or refund the purchase price paid for “LED Product” that TWR[®] verifies as being inoperable due to original design, material, or workmanship. All warranty replacement “LED Product” is warranted only for the remainder of the original warranty of the “LED Product” replaced. Replacement “LED Product” will be equivalent in function, but not necessarily identical, to the replaced “LED Product.”

TWR Lighting[®], Inc. (“TWR[®]”) warrants its “LED Product” against light degradation for a period of five (5) years from the date of installation. TWR[®], at its sole option, will, itself, or through others, repair, replace, or refund the purchase price paid for “LED Product” that TWR[®] verifies as failing to meet 75% of the minimum intensity requirements as defined in the FAA Advisory Circular 150/5345-43G dated 09/26/12. All warranty replacement “LED Product” is warranted only for the remainder of the original warranty of the “LED Product” replaced. Replacement “LED Product” will be equivalent in function, but not necessarily identical, to the replaced “LED Product.”

Replacement parts (other than “LED Product”) are warranted for 90 days from the date of shipment.

Conditions not covered by this Warranty, or which might void this Warranty are as follows:

- x Improper Installation or Operation
- x Misuse
- x Abuse
- x Unauthorized or Improper Repair or Alteration
- x Accident or Negligence in Use, Storage, Transportation, or Handling
- x Any Acts of God or Nature
- x **Non-OEM Parts**

The use of Non-OEM parts or modifications to original equipment design will void the manufacturer warranty and could invalidate the assurance of complying with FAA requirements as published in Advisory Circular 150/5345-43.

TWR Lighting, Inc. HARK[®]

Enlightened Technology[®]

AA3-TSS CONTROLLER

Warranty & Return Policy (continued)

Field Service – Labor, Travel, and Tower Climb are not covered under warranty. Customer shall be obligated to pay for all incurred charges. An extensive network of certified and insured Service Representatives is available if requested.

Return Terms – You must first contact our Customer Service Department at **713-973-6905** to acquire a Return Merchandise Authorization (RMA) number in order to return the product(s). Please have the following information available when requesting an RMA number:

- x The contact name and phone number of the tower owner
- x The contact name and phone number of the contractor
- x The site name and number
- x The part number(s)
- x The serial number(s) (if any)
- x A description of the problem
- x The billing information
- x The Ship To address

This RMA number must be clearly visible on the outside of the box. If the RMA number is not clearly labeled on the outside of the box, your shipment will be refused. Please ensure the material you are returning is packaged carefully. **The warranty is null and void if the product(s) are damaged in the return shipment.**

All RMAs must be received by TWR LIGHTING[®], INC., 4300 WINDFERN RD #100, HOUSTON TX 77041-8943, within 30 days of issuance.

Upon full compliance with the Return Terms, TWR[®] will replace, repair and return, or credit product(s) returned by the customer. It is TWR[®]'s sole discretion to determine the disposition of the returned item(s).

TWR Lighting, Inc. HARK[®]

Enlightened Technology[®]

AA3-TSS CONTROLLER

Warranty & Return Policy (continued)

Replacements – Replacement part(s) will be shipped and billed to the customer for product(s) considered as Warranty, pending return of defective product(s). When available, a certified reconditioned part is shipped as warranty replacement with a Return Merchandise Authorization (RMA) number attached. Upon receipt of returned product(s), inspection, testing, and evaluation will be performed to determine the cause of defect. The customer is then notified of the determination of the testing.

- x Product(s) that is deemed defective and/or unrepairable and covered under warranty - a credit will be issued to the customer's account.
- x Product(s) found to have no defect will be subject to a **\$75.00 per hour testing charge (1 hour minimum), which will be invoiced to the customer.** At this time the customer may decide to have the tested part(s) returned and is responsible for the return charges.
- x Product(s) under warranty, which the customer does not wish returned, the customer will be issued a credit against the replacement invoice.

Repair & Return – A Return Merchandise Authorization (RMA) will be issued for all part(s) returned to TWR[®] for repair. Upon receipt of returned product(s), inspection, testing, and evaluation will be performed to determine the cause of defect. The customer is then notified of the determination of the testing. If the returned part(s) is deemed unrepairable, or the returned part(s) is found to have no defect, the customer will be subject to a **\$75.00 per hour testing charge (1 hour minimum), which will be invoiced to the customer.** Should the returned parts be determined to be repairable, a written estimated cost of repair will be sent to the customer for their written approval prior to any work being performed. In order to have the tested part(s) repaired and/or returned, the customer must issue a purchase order and is responsible for the return shipping charges.

Return to Stock – Any order that is returned to TWR[®] for part(s) ordered incorrectly by the customer, or unneeded upon receipt, the customer is required to pay a **20% restocking fee.** A credit will be issued once it is determined that the Return Terms are met.

Credits – Credits are issued once it is determined that all of the Warranty and Return Terms are met. All credits are processed on Fridays. In the event a Friday falls on a Holiday, the credit will be issued on the following Friday.

Freight – All warranty replacement part(s) will be shipped via ground delivery and paid for by TWR[®]. Delivery other than ground is the responsibility of the customer.

TWR Lighting, Inc. HARK[®]

Enlightened Technology[®]

AA3-TSS CONTROLLER

Warranty & Return Policy (continued)

REMEDIES UNDER THIS WARRANTY ARE LIMITED TO PROVISIONS OF REPLACEMENT PARTS AND REPAIRS AS SPECIFICALLY PROVIDED. IN NO EVENT SHALL TWR[®] BE LIABLE FOR ANY OTHER LOSSES, DAMAGES, COSTS, OR EXPENSES INCURRED BY THE CUSTOMER, INCLUDING, BUT NOT LIMITED TO, LOSS FROM FAILURE OF THE PRODUCT(S) TO OPERATE FOR ANY TIME, AND ALL OTHER DIRECT, INDIRECT, SPECIAL, INCIDENTAL, OR CONSEQUENTIAL DAMAGES, INCLUDING ALL PERSONAL INJURY OR PROPERTY DAMAGE DUE TO ALLEGED NEGLIGENCE, OR ANY OTHER LEGAL THEORY WHATSOEVER. THIS WARRANTY IS MADE BY TWR[®] EXPRESSLY IN LIEU OF ALL OTHER WARRANTIES, WHETHER EXPRESSED OR IMPLIED. WITHOUT LIMITING THE GENERALITY OF THE FORGOING, TWR[®] MAKES NO WARRANTY OF MERCHANTABILITY OR FITNESS OF THE PRODUCT(S) FOR ANY PARTICULAR PURPOSE. TWR[®] EXPRESSLY DISCLAIMS ALL OTHER WARRANTIES.

TWR Lighting, Inc. HARK®

Enlightened Technology®

AA3-TSS CONTROLLER

RETURN MERCHANDISE AUTHORIZATION (RMA) FORM

RMA#: _____ **DATE:** _____

CUSTOMER: _____

CONTACT: _____ **PHONE NO.:** _____

ITEM DESCRIPTION (PART NO.): _____

MODEL NO.: _____ **SERIAL NO.:** _____

ORIGINAL TWR INVOICE NO.: _____ **DATED:** _____

DESCRIPTION OF PROBLEM: _____

SIGNED _____ **DATE NEEDED** _____

RETURN ADDRESS: _____

PLEASE RETURN PRODUCT TO: 4300 WINDFERN RD #100 HOUSTON TX 77041-8943

TWR Lighting, Inc. HARK®

Enlightened Technology®

AA3-TSS CONTROLLER

RETURN MERCHANDISE AUTHORIZATION (RMA) FORM

RMA#: _____ **DATE:** _____

CUSTOMER: _____

CONTACT: _____ **PHONE NO.:** _____

ITEM DESCRIPTION (PART NO.): _____

MODEL NO.: _____ **SERIAL NO.:** _____

ORIGINAL TWR INVOICE NO.: _____ **DATED:** _____

DESCRIPTION OF PROBLEM: _____

SIGNED _____ **DATE NEEDED** _____

RETURN ADDRESS: _____

PLEASE RETURN PRODUCT TO: 4300 WINDFERN RD #100 HOUSTON TX 77041-8943

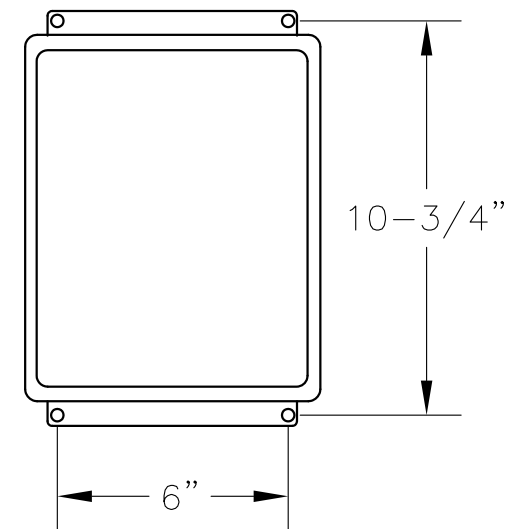
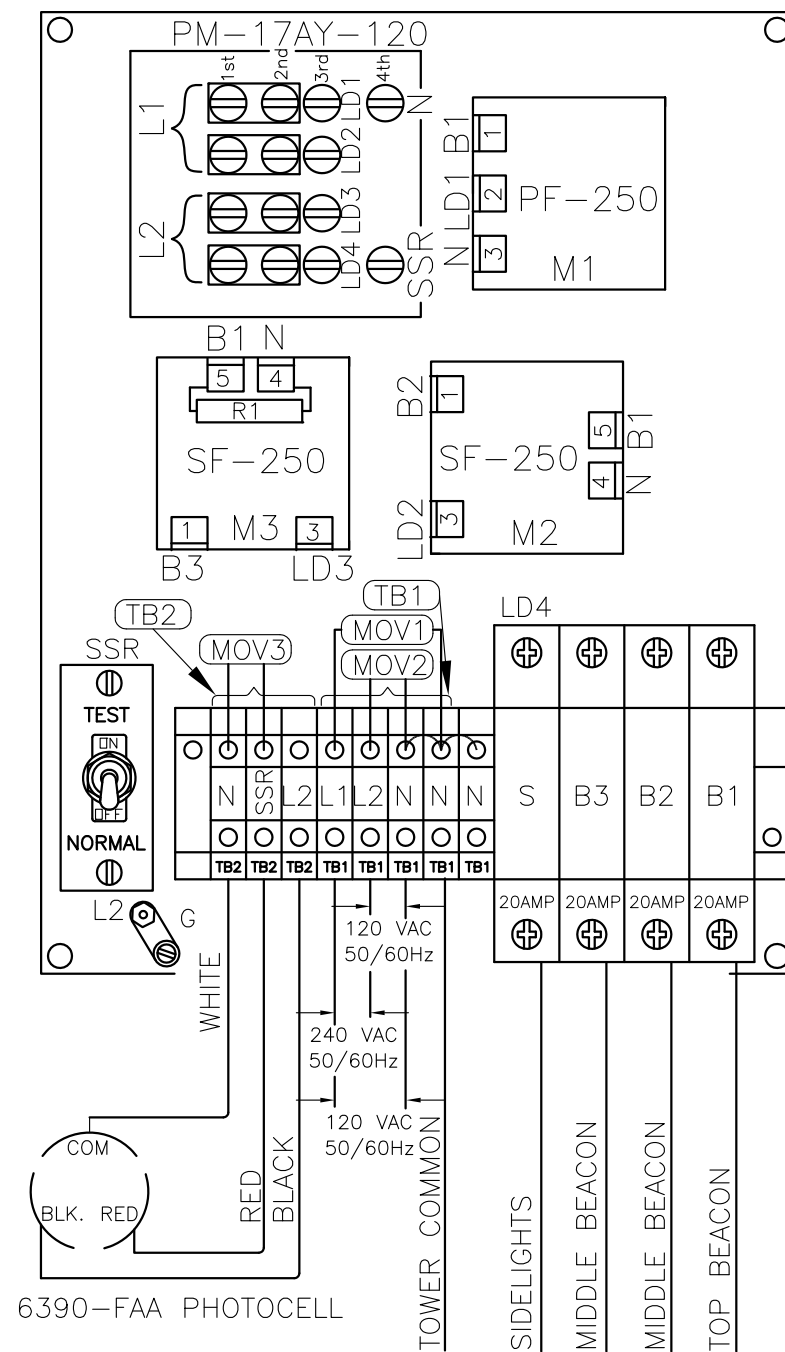

MOUNTING DIMENSIONS
(FOR CABINET)

NOTES:

1. WHEN REPLACING MODULES USE HEAT SINK COMPOUND BETWEEN MODULE AND ALUMINUM PLATE.
2. PLUG 6390-FAA PHOTOCCELL INTO 43109 TWIST LOCK RECEPTACLE AND TWIST TO LOCK.
3. WIRES ARE CONNECTED LETTER TO LETTER. (EXAMPLE) S TO S TO S.

AA3-TSS CHASSIS COMPONENT LAYOUT			
PROD DEPT	TWR Lighting, Inc. <i>Enlightened Technology</i>		
SERV DEPT			
ENGINEER			
DRAWN BY	G.D. SEBEK	SHEET SIZE	B
DATE	05/26/93	SCALE	N.T.S.
		DWG. NO.	1098-R
<small>The use of non-OEM parts or modifications to original equipment design will void the manufacturer warranty and could invalidate the assurance of complying with FAA requirements as published in Advisory Circular 150/5345-43.</small>			
<small>NOTICE: The drawings and photographic images contained herein are the sole property of TWR Lighting, Inc. All information contained herein that is not generally known shall be considered confidential except to the extent the information has been previously established. The drawings and photographic images contained herein may not be reproduced, copied or used as the basis for manufacture or sale or promotion or any other purpose without the expressed written permission of TWR Lighting, Inc.</small>			

10/22/09	(B)	MODULES, PHOTC.
DATE:	LTR.	REVISION

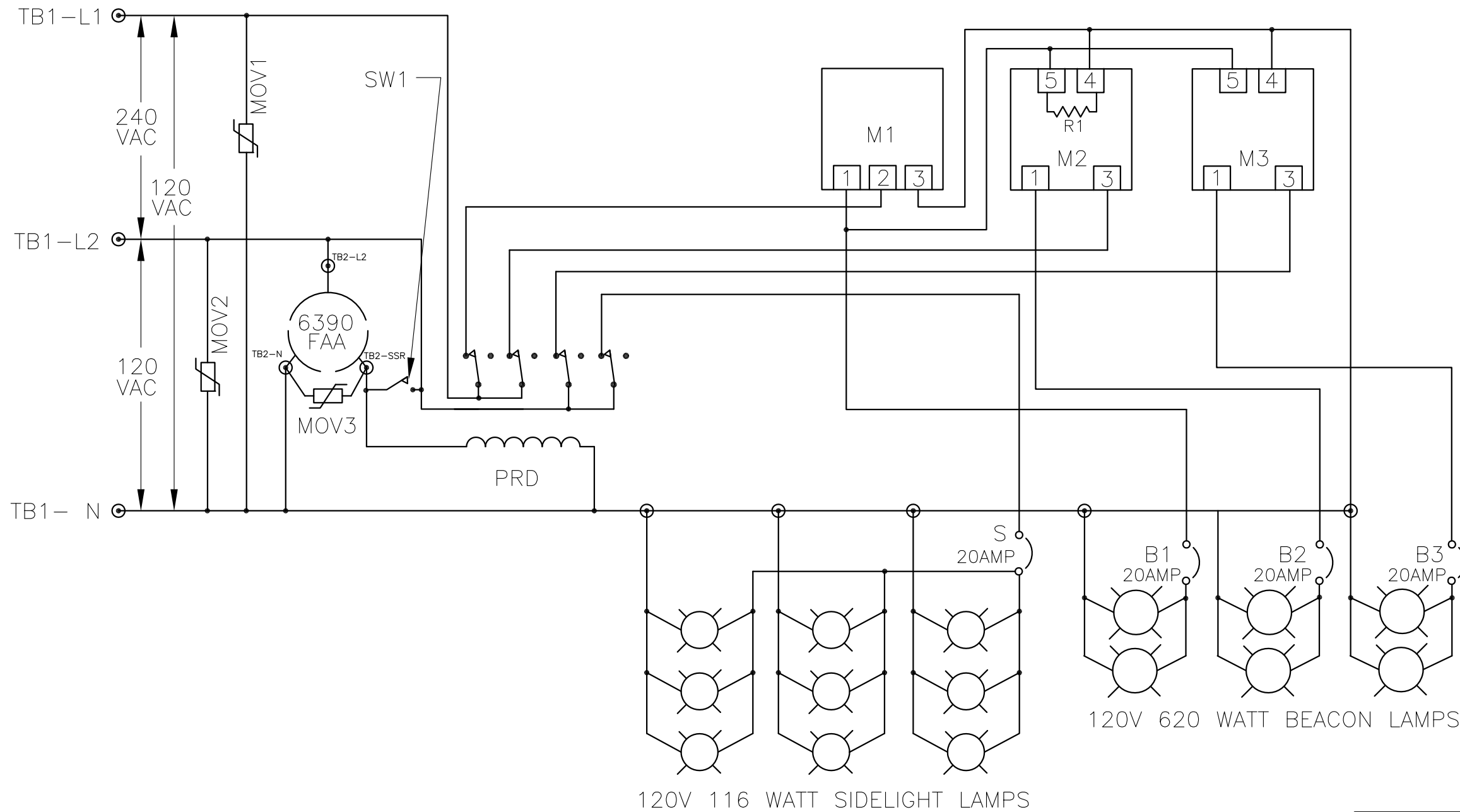

AA3-TSS SCHEMATIC

ENGINEER	TWR Lighting, Inc. <i>Enlightened Technology®</i>		
APPROVED			
APPROVED			
APPROVED	DRAWN BY G.D. SEBEK	SHEET SIZE B	SHEET QTY. 1 OF 1
APPROVED	DATE 05/27/1993	SCALE N.T.S.	DWG. NO. 1098-S

10/22/09	PHOTOCELL
DATE:	REVISION

The use of non-OEM parts or modifications to original equipment design will void the manufacturer warranty and could invalidate the assurance of complying with FAA requirements as published in Advisory Circular 150/5345-43.
NOTICE: The drawings and photographic images contained herein are the sole property of TWR Lighting, Inc. All information contained herein that is not generally known shall be considered confidential except to the extent the information has been previously established. The drawings and photographic images contained herein may not be reproduced, copied or used as the basis for manufacture or sale or promotion or any other purpose without the expressed written permission of TWR Lighting, Inc.

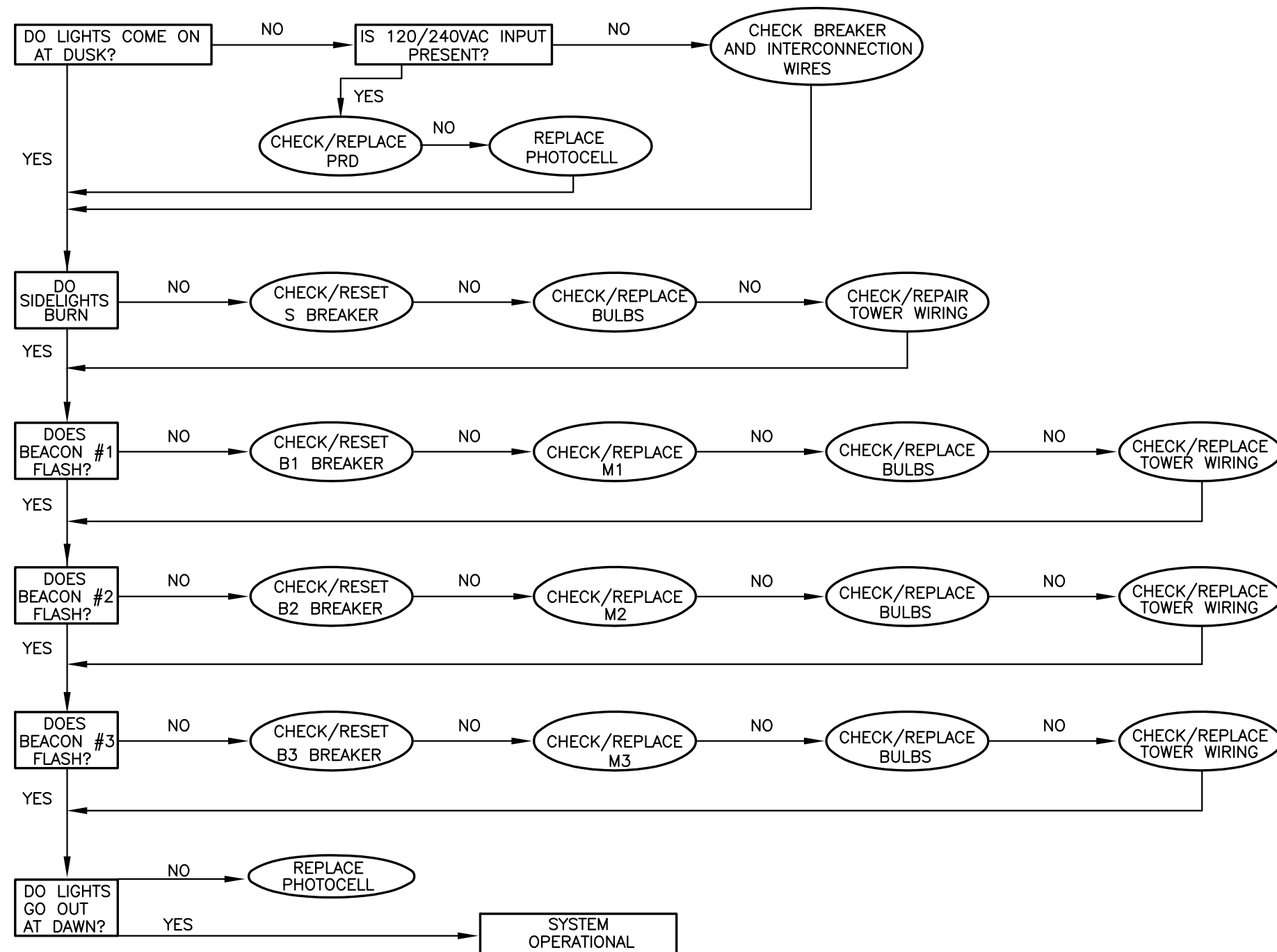

TROUBLESHOOTING FLOW CHART			
AA3-TSS			
ENGINEER	TWR Lighting, Inc. <i>Enlightened Technology®</i>		
APPROVED			
APPROVED			
APPROVED	DRAWN BY G.D. SEBEK	SHEET SIZE B	SHEET QTY. 1 OF 1
APPROVED	DATE 02/27/1993	SCALE N.T.S.	DWG. NO. 1098-F

05/19/03	(A)	CHG. TO BREAKERS
DATE:	LTR.	REVISION

The use of non-OEM parts or modifications to original equipment design will void the manufacturer warranty and could invalidate the assurance of complying with FAA requirements as published in Advisory Circular 150/5345-43.
 NOTICE: The drawings and photographic images contained herein are the sole property of TWR Lighting, Inc. All information contained herein that is not generally known shall be considered confidential except to the extent the information has been previously established. The drawings and photographic images contained herein may not be reproduced, copied or used as the basis for manufacture or sale or promotion or any other purpose without the expressed written permission of TWR Lighting, Inc.

BILL OF MATERIALS

ITEM NO.	QTY.	TWR PART NO.	DESCRIPTION
1	3	BEACON	300 MM BEACON RED
2	6	620PS40P	620 WATT 120 VOLT LAMP
3	6	OL1	3/4" OBSTRUCTION LIGHT
4	6	116A21TS	116 WATT 120 VOLT LAMP
5	3	CGB295SA	3/4" CORD CONNECTOR
6	2	JB5	3/4" JUNCTION BOX
7	3	JB8	1" JUNCTION BOX
8	5	UNY205	3/4" UNION
9	3	UNY305	1" UNION
10	4	T27CG	3/4" CONDULET W/COVER AND GASKET
11	2	T37CG	1" CONDULET W/COVER AND GASKET
12	1	EL3490	3/4" 90° SHORT ELBOW
13	2	EL3430	3/4" 30° ELBOW
14	2	EL190	1" 90° ELBOW
15	3	5012902	3/4" BREATHER
16	2	SS10012	WRAPLOCK
17	2	PIPDOP	4 oz. PIPE DOPE
18	16	A314	3/4" CONDUIT LOCKNUTS
19	9	A315	1" CONDUIT LOCKNUTS
20	3	RE32	1" TO 3/4" REDUCER
21	16	CPLG34	3/4" GALVANIZED COUPLING
22	2	N34T3	3/4" x 3" NIPPLE
23	6	HC402	3/4" NO THREAD CONNECTOR
24	60'	CONDUIT34	3/4" CONDUIT (FOR OL)
25	6	SLPIGTAIL25	25' SIDELIGHT PIGTAIL
26	1	AA2/3	AA2/3 CONTROLLER

ITEM NUMBERS #27-#35 ARE NOT INCLUDED IN THE KIT BUT ARE AVAILABLE UPON REQUEST, AND REQUIRED FOR INSTALLATION.

27	-	CONDUIT34	3/4" CONDUIT (1/2 TOWER HT.)
28	-	CONDUIT1	1" CONDUIT (1/2 TOWER HT. + 30'/9M)
29	-	4THHNWHT	#4 THHN WHT. WIRE (TOWER HT.+40'/12M)
30	-	6THHNBLK	#6 THHN BLK. WIRE (TOWER HT.+40'/12M)
31	-	8THHNWHT	#8 THHN WHT. WIRE (1/2 TOWER HT.+40'/12M)
32	-	8THHNBLUE	#8 THHN BLUE WIRE (1/2 TOWER HT.+40'/12M)
33	-	8THHNBLUE	#8 THHN BLUE WIRE (1/2 TOWER HT.+40'/12M)
34	-	12THHNRED	#12 THHN RED WIRE (3/4 TWR HT.+40'/12M)
35	-	12THHNYLW	#12 THHN YLW. WIRE (1/4 TWR HT.+40'/12M)

* = ITEMS NOT SHOWN

NOTES:

- 1) PART #CONDUIT34 CUT TO LENGTH FOR PROPER EXTENSION OF OL1 (6"-12") FROM STRUCTURE. ATTACH PART #HC402 TO UNTHREADED CONDUIT TO COMPLETE ASSEMBLY.
- 2) CONDUIT SIZE BASED ON USING TYPE THHN WIRE.
- 3) USE RIGID GALVANIZED STEEL CONDUIT.
- 4) BREATHERS ALLOW FOR CIRCULATION OF AIR TO PREVENT CONDENSATION.
- 5) USE COUPLING THAT IS PROVIDED WITH PART #CONDUIT34 TO ATTACH ITEM EL3430 TO PART #HC402.
- 6) MIDDLE LEVEL BEACON CAN NOT BE MOUNTED AT LESS THAN 200'/61M

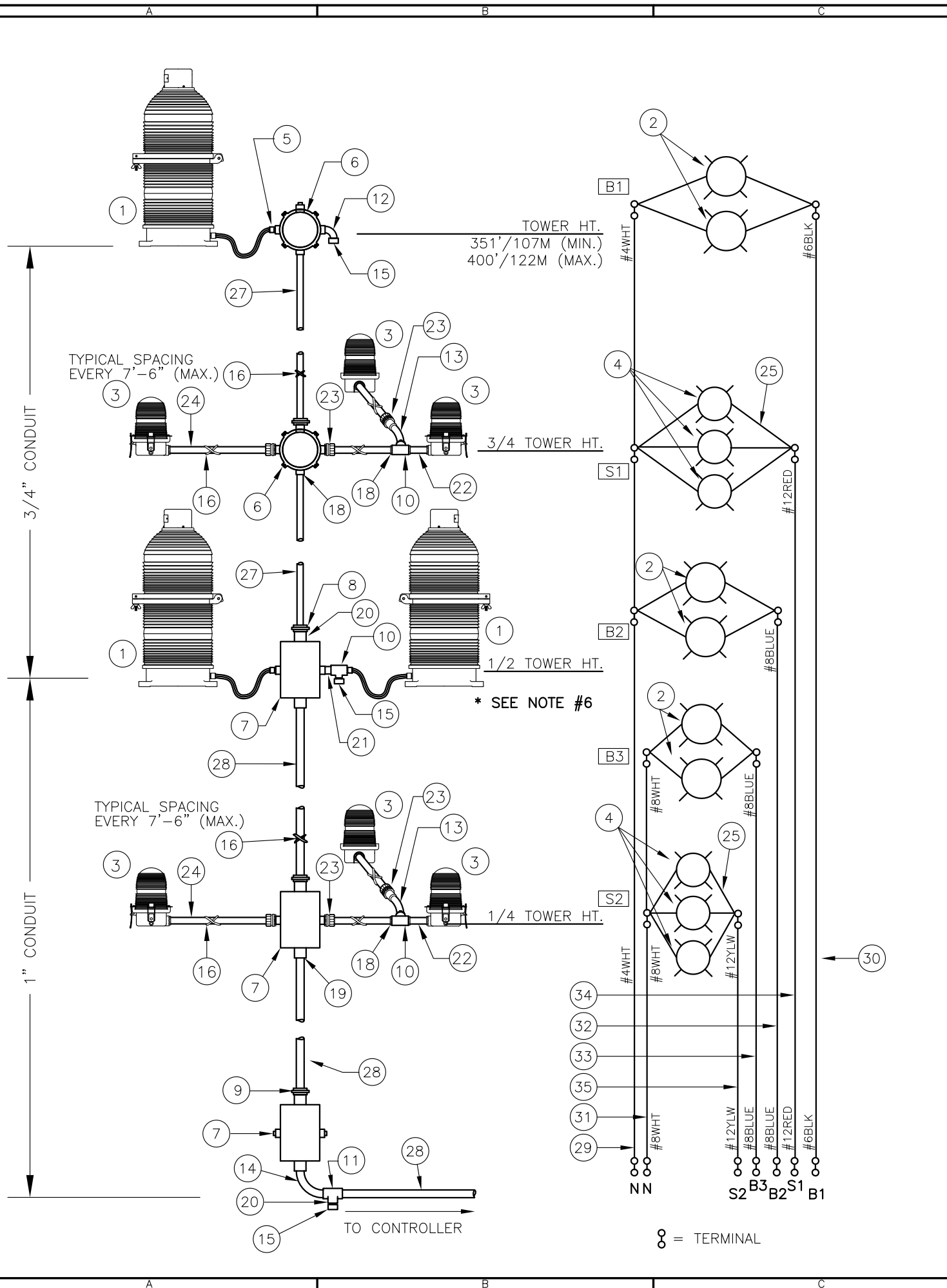
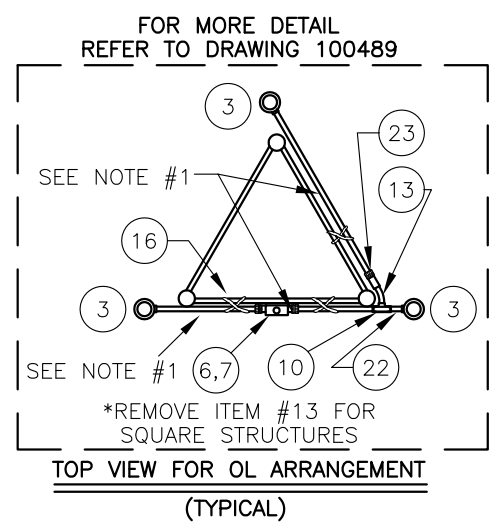

12/04/07	(E)	CHG OL ARRANGEMENT
DATE:	LTR.	REVISION

LK1A2/3 TOWER LIGHTING KIT W/NO BOOST
(TOWERS 351'/107M TO 400'/122M)

PROD DEPT	TWR Lighting, Inc. Enlightened Technology®	
SERV DEPT		
ENGINEER		
DRAWN BY E.A.SALAZAR	SHEET SIZE B	SHEET QTY. 1 OF 1
DATE 04/16/93	SCALE N.T.S.	DWG. NO. 261-31

The use of non-OEM parts or modifications to original equipment design will void the manufacturer warranty and could invalidate the assurance of complying with FAA requirements as published in Advisory Circular 150/5345-43.
NOTICE: The drawings and photographic images contained herein are the sole property of TWR Lighting, Inc. All information contained herein that is not generally known shall be considered confidential except to the extent the information has been previously established. The drawings and photographic images contained herein may not be reproduced, copied or used as the basis for manufacture or sale or promotion or any other purpose without the expressed written permission of TWR Lighting, Inc.

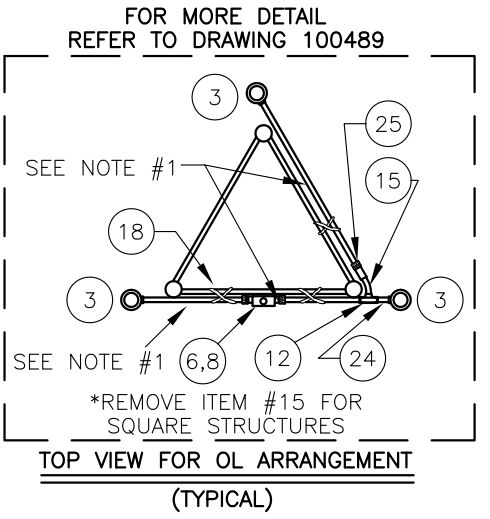
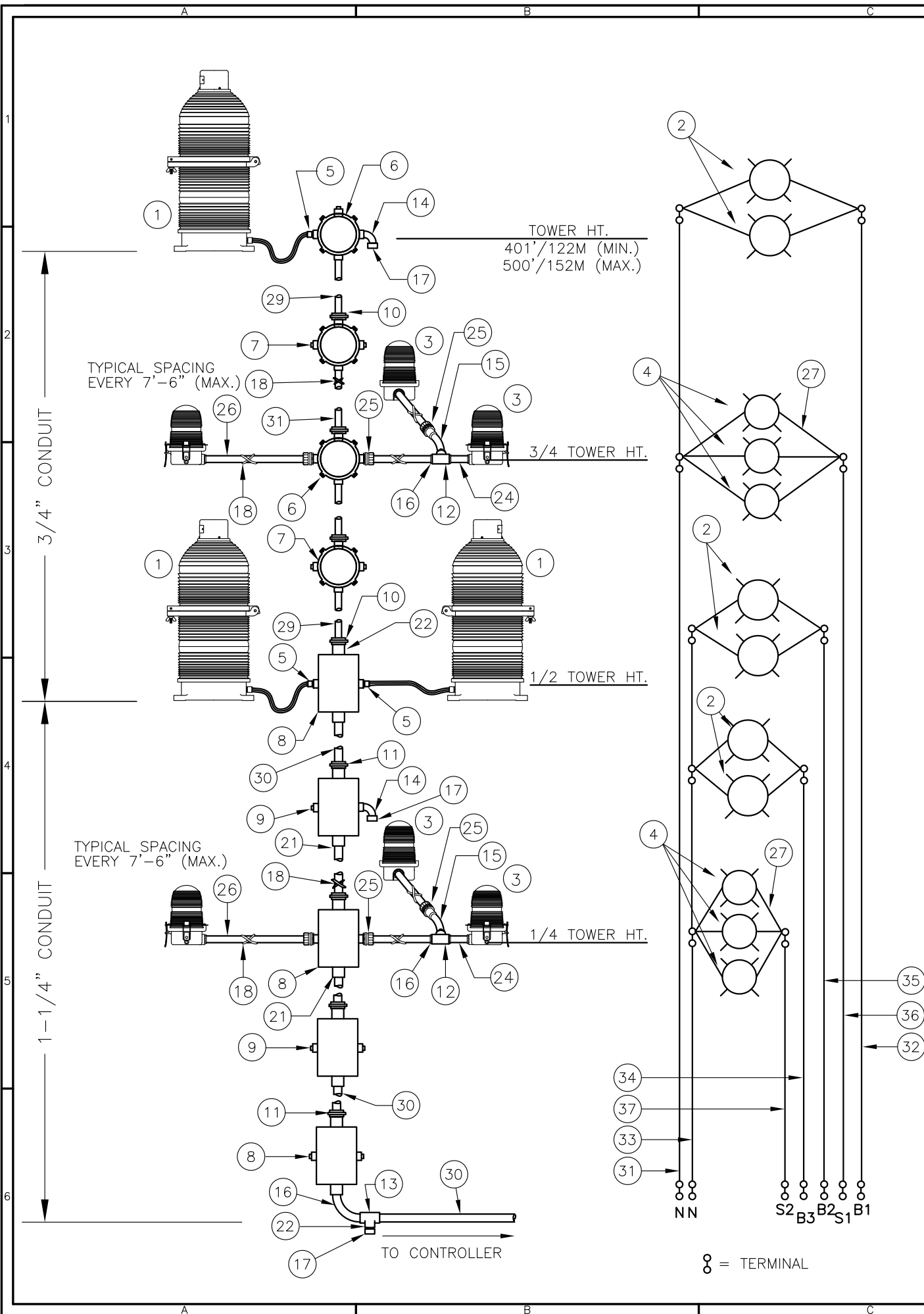

- NOTES:
- 1) PART #CONDUIT34 CUT TO LENGTH FOR PROPER EXTENSION OF OL1 (6"-12") FROM STRUCTURE. ATTACH PART #HC402 TO UNTHREADED CONDUIT TO COMPLETE ASSEMBLY.
 - 2) CONDUIT SIZE BASED ON USING TYPE THHN WIRE.
 - 3) USE RIGID GALVANIZED STEEL CONDUIT.
 - 4) BREATHERS ALLOW FOR CIRCULATION OF AIR TO PREVENT CONDENSATION.
 - 5) USE COUPLING THAT IS PROVIDED WITH PART #CONDUIT34 TO ATTACH ITEM EL3430 TO PART #HC402.

BILL OF MATERIALS

ITEM NO.	QTY.	TWR PART NO.	DESCRIPTION
1	3	BEACON	300 MM BEACON RED
2	6	620PS40P	620 WATT 120 VOLT LAMP
3	6	OL1	3/4" OBSTRUCTION LIGHT
4	6	116A21TS	116 WATT 120 VOLT LAMP
5	3	CGB295SA	3/4" CORD CONNECTOR
6	2	JB5	3/4" JUNCTION BOX
7	2	JB0	3/4" STRAIN RELIEF BOX
8	3	JB8114	1-1/4" JUNCTION BOX
9	2	JB8SR114	1-1/4" STRAIN RELIEF BOX
10	5	UNY205	3/4" UNION
11	5	UNY405	1-1/4" UNION
12	3	T27CG	3/4" CONDULET W/COVER AND GASKET
13	2	T47CG	1-1/4" CONDULET W/COVER AND GASKET
14	2	EL3490	3/4" 90° SHORT ELBOW
15	2	EL3430	3/4" 30° ELBOW
16	2	EL11490	1-1/4" 90° ELBOW
17	3	5012902	3/4" BREATHER
18	2	SS10012	WRAPLOCK
* 19	2	PIPDOP	4 oz. PIPE DOPE
20	19	A314	3/4" CONDUIT LOCKNUTS
21	13	A316	1-1/4" CONDUIT LOCKNUTS
22	3	RE42	1-1/4" TO 3/4" REDUCER
* 23	16	CPLG34	3/4" GALVANIZED COUPLING
24	2	N34T3	3/4" x 3" NIPPLE
25	6	HC402	3/4" NO THREAD CONNECTOR
26	60'	CONDUIT34	3/4" CONDUIT (FOR OL)
27	6	SLPIGTAIL25	25' SIDELIGHT PIGTAIL
* 28	1	AA3	AA3 CONTROLLER
29	-	CONDUIT34	3/4" CONDUIT (1/2 TOWER HT.)
30	-	CONDUIT114	1-1/4" CONDUIT (1/2 TOWER HT. + 30'/9M)
31	-	4THHNWHT	#4 THHN WHT. WIRE (TOWER HT.+40'/12M)
32	-	4THHNBLK	#4 THHN BLK. WIRE (TOWER HT.+40'/12M)
33	-	4THHNWHT	#4 THHN WHT. WIRE (1/2 TOWER HT.+40'/12M)
34	-	6THHNBLUE	#6 THHN BLUE WIRE (1/2 TOWER HT.+40'/12M)
35	-	6THHNBLUE	#6 THHN BLUE WIRE (1/2 TOWER HT.+40'/12M)
36	-	12THHNRED	#12 THHN RED WIRE (3/4 TWR HT.+40'/12M)
37	-	12THHNYLW	#12 THHN YLW. WIRE (1/4 TWR HT.+40'/12M)

ITEM NUMBERS #29-#37 ARE NOT INCLUDED IN THE KIT BUT ARE AVAILABLE UPON REQUEST, AND REQUIRED FOR INSTALLATION.

* = ITEMS NOT SHOWN

LK2A2/3 TOWER LIGHTING KIT W/NO BOOST
(TOWERS 401'/122M TO 500'/152M)

PROD DEPT	TWR Lighting, Inc. Enlightened Technology®	SHEET SIZE	SHEET QTY.
SERV DEPT		B	1 OF 1
ENGINEER			
DRAWN BY	E.A.SALAZAR	SCALE	N.T.S.
DATE	02/02/93	DWG. NO.	261-32

The use of non-OEM parts or modifications to original equipment design will void the manufacturer warranty and could invalidate the assurance of complying with FAA requirements as published in Advisory Circular 150/5345-43.
NOTICE: The drawings and photographic images contained herein are the sole property of TWR Lighting, Inc. All information contained herein that is not generally known shall be considered confidential except to the extent the information has been previously established. The drawings and photographic images contained herein may not be reproduced, copied or used as the basis for manufacture or sale or promotion or any other purpose without the expressed written permission of TWR Lighting, Inc.

12/03/07	D	CHG OL ARRANGEMENT
DATE:	LTR.	REVISION

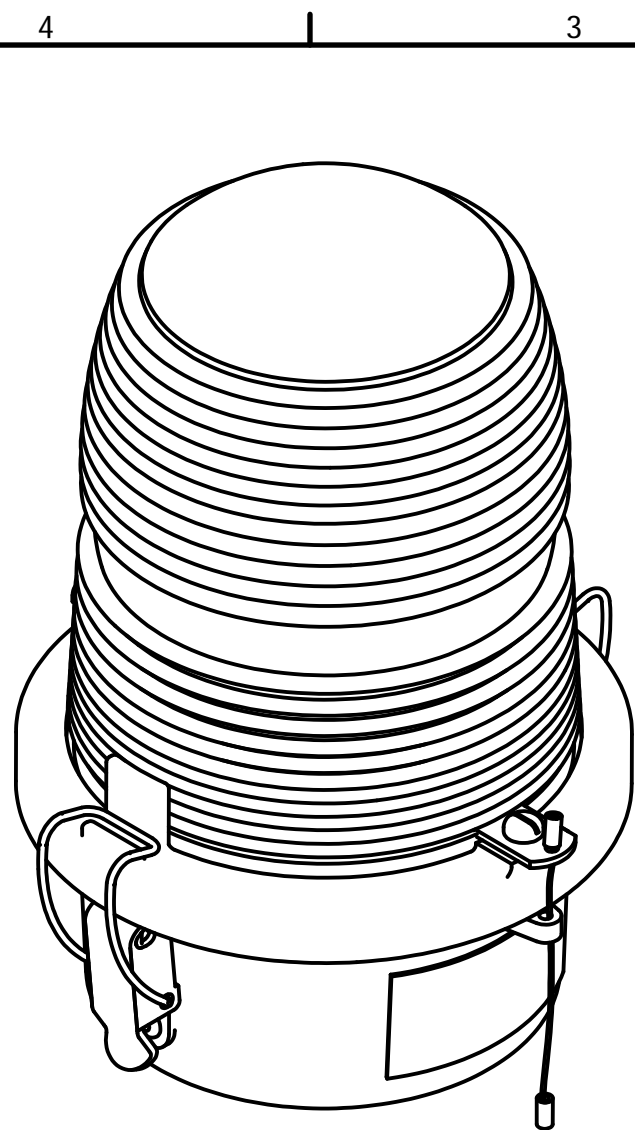

PARTS LIST			
ITEM	QTY	PART NUMBER	DESCRIPTION
1	1	AP35222	RED SIDELIGHT GLASS
2	1	105C	SINGLE SIDELIGHT BODY
3	1	106C	LENS HOLDER RING
4	2	12V245	OL LENS CLIP
5	2	832X14PH	8-32 X 1/4" PH SS SLOT SCREW
6	2	HC255SS	SIDELIGHT LATCH
7	1	7X7SS	1/16 HOL 7X7 S.S. WIRE
8	2	A1A	STAKON CRIMP
9	1	OLG	OL GASKET
10	1	TWR19062	SIDELIGHT RECEPTACLE
11	4	18PRSS	1/8 X .40 SS POP RIVET
12	1	A314	3/4" CONDUIT LOCKNUT GALV.
*	2	104G	WHITE TEFLON WASHER
14	2	832X34PH	8-32 X 3/4" S.S. RH SLOT
15	1	100327	OL1 SERIAL NUMBER LABEL
~	1	116A21TS	116W-120V LAMP (TYP.)

* = PART NOT SHOWN
 ~ = PART SOLD SEPARATELY

NOTE:
 1. FAA APPROVED LIGHT USES THE 116A21TS LAMP.
 OTHER LAMPS ARE AVAILABLE TO MEET YOUR APPLICATION.

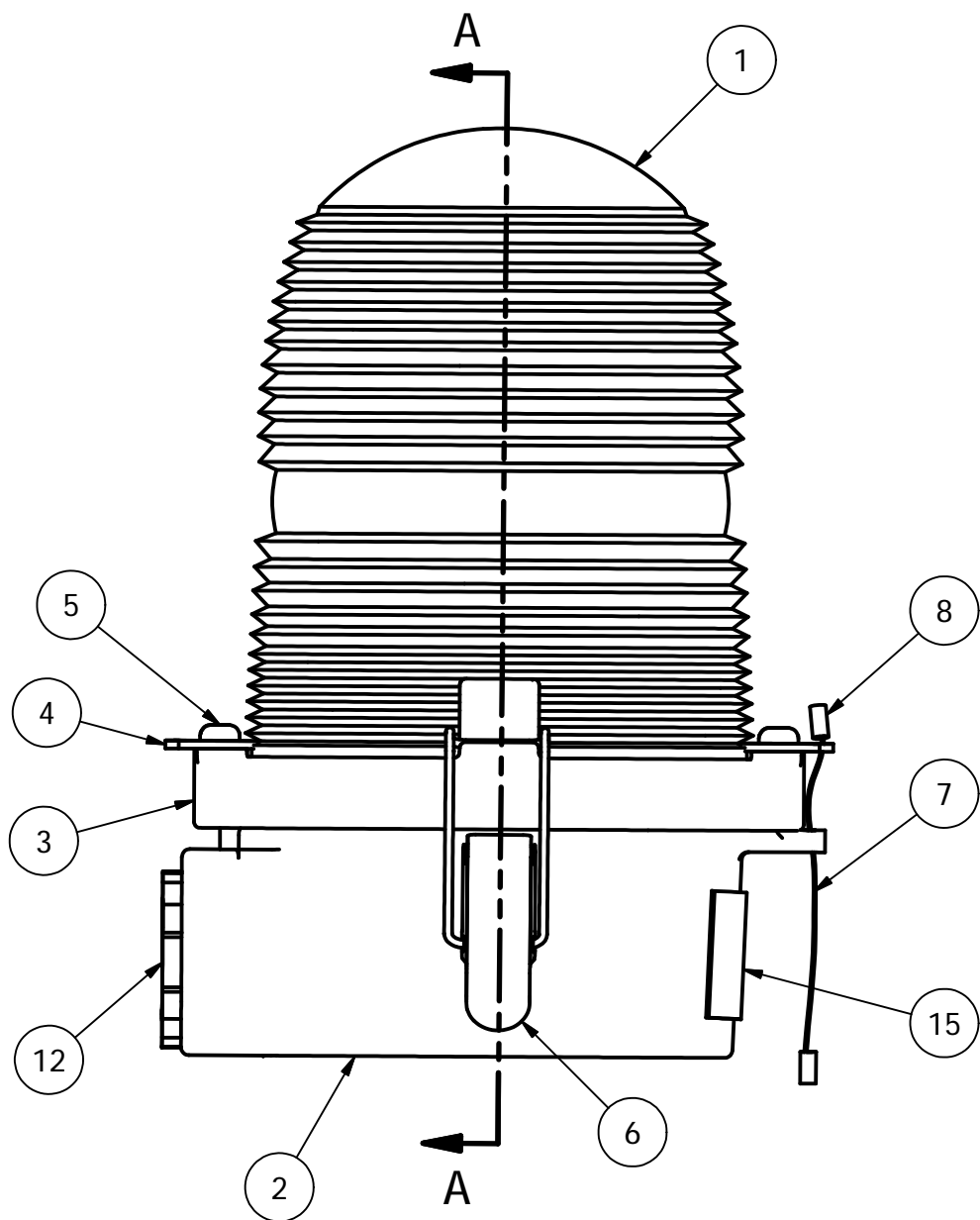

SECTION A-A

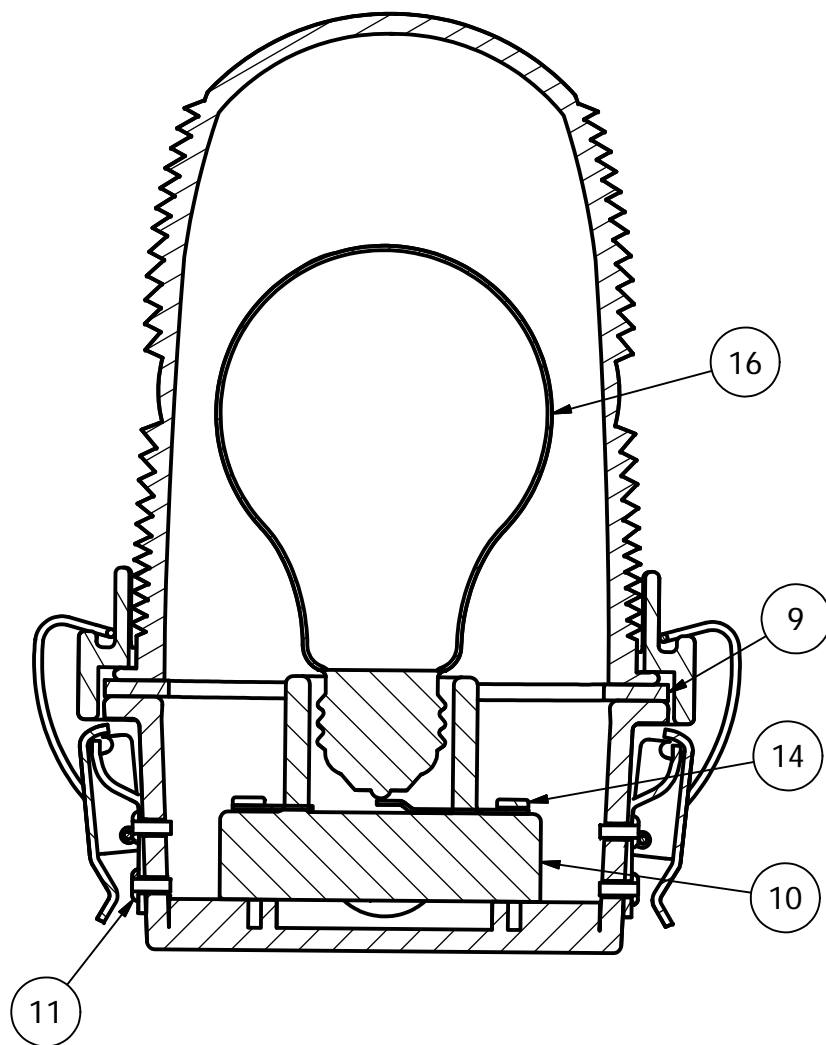

DRAWN	vhernandez	2/13/2012
CHECKED		
QA		
MFG		
APPROVED		

TWR Lighting, Inc.
Enlightened Technology

TITLE
 3/4" OL1 SIDE HUB
 ASSEMBLY DETAIL (PART#OL1)

SIZE	B	DWG NO	279-OL	REV	C
SCALE	2/3	SHEET 1 OF 1			

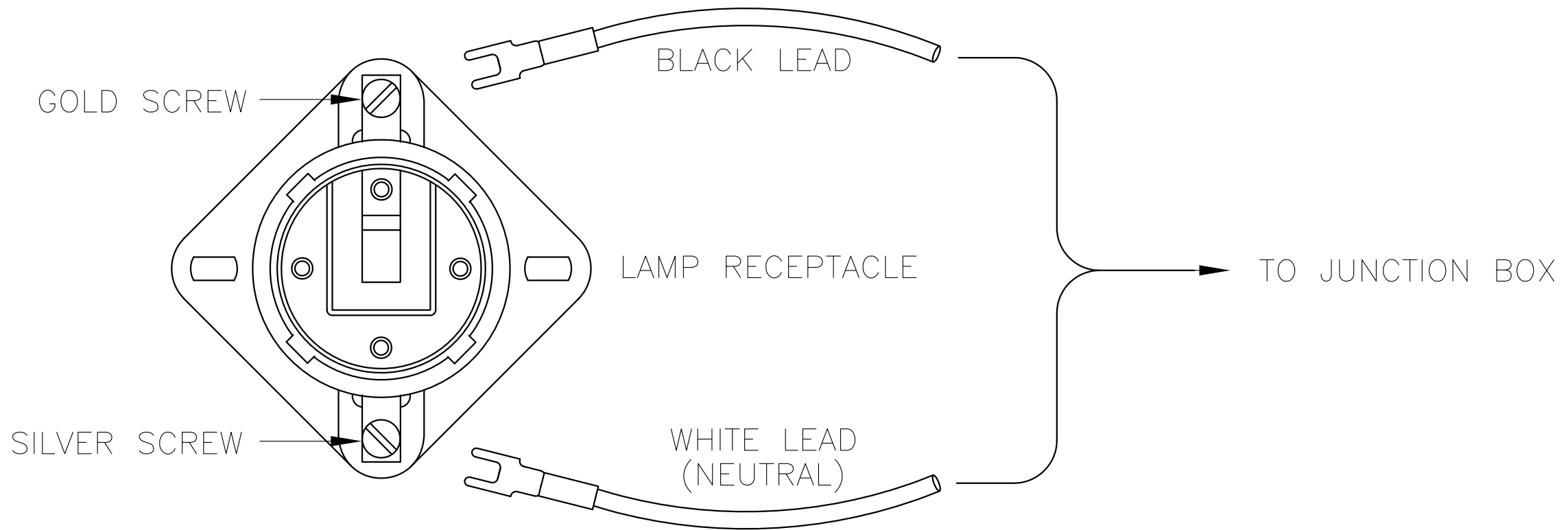

SIDELIGHT RECEPTACLE WIRING			
PROD DEPT	TWR Lighting, Inc. <i>Enlightened Technology</i> WORK		
SERV DEPT			
ENGINEER			
DRAWN BY	G.D. SEBEK	SHEET SIZE	SHEET QTY.
DATE	06/08/91	B	1 OF 1
		SCALE	DWG. NO.
		N.T.S.	274-S

7/2/98	(A)	CHANGED LABEL
DATE:	LTR.	REVISION

NOTICE: The use of non-OEM parts or modifications to original equipment design will void the manufacturer warranty and could invalidate the assurance of complying with FAA requirements as published in Advisory Circular 150/5345-43. The drawings and photographic images contained herein are the sole property of TWR Lighting, Inc. All information contained herein that is not generally known shall be considered confidential except to the extent the information has been previously established. The drawings and photographic images contained herein may not be reproduced, copied or used as the basis for manufacture or sale or promotion or any other purpose without the expressed written permission of TWR Lighting, Inc.

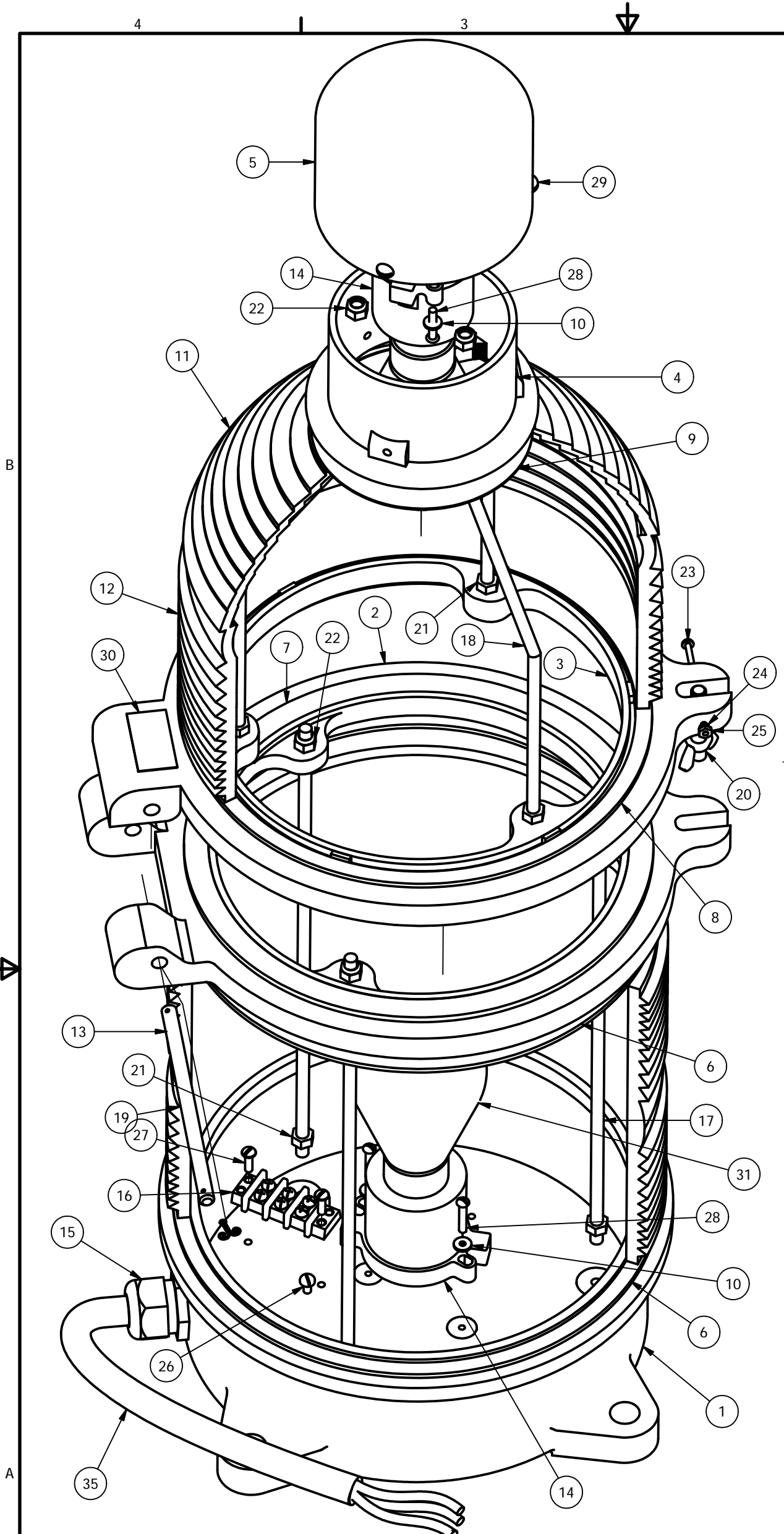

Parts List			
ITEM	QTY	PART NUMBER	DESCRIPTION
1	1	100C	BEACON BASE
2	1	101C	LOWER HINGE
3	1	102C	UPPER HINGE
4	1	103C	CANOPY CAP
5	1	104C	CANOPY FLANGE
6	2	100G	GASKET BEACON BASE
7	1	101G	GASKET MIDDLE BEACON
8	1	102G	GASKET, TOP HINGE
9	1	103G	GASKET TEFLON, TOP
10	4	104G	WHITE TEFLON WASHER
11	1	AP3557	CAP LENS RED
12	1	AP3556	MIDDLE LENS RED
13	2	AP3555	BOTTOM LENS RED
14	2	TWR23-546	BEACON LAMP RECEPTACLE
15	1	CGB295SA	3/4" CORD CONNECTOR .62 TO .75
16	1	TERMBLK3	TERMINAL BLOCK 3-PART
17	3	BTRS-1	BEACON TIE ROD STRAIGHT
18	3	BTRB	BEACON TIE ROD BENT
19	1	BHP	BEACON HINGE PIN W/ COTTER PIN
20	1	BLP	BEACON LATCH PIN
21	6	516NUT	5/16-15 HEX NUT
22	6	516NUTN	5/16-18 NUT W/NYLON INSERT
23	1	632X2RH	6-32 X 2 SS RH SLOT SCREW
24	1	632LW	6-32 LOCK WASHER
25	1	632NUT	6-32 NUT HEX
26	1	1032x38BH	10-32 X 3/8 PILLIPS PAN HEAD
27	2	1032x58PH	10-32 X 5/8 PH SLOT SCREW
28	4	1032X1RH	10-32 X 1 SS RH SCREW
29	3	1420X58RH	14-20 X 5/8 RH SLOT SCREW
30	1	100328	BEACON SERIAL NUMBER LABEL
31	2	---	BEACON LAMP
*	32	7	TYZ23M HI TEMP TY WRAPS T&B TEFZEL
*	33	4'	16HTWH #16 HI-TEMP WIRE SRML WHITE
*	34	4'	16HTBL #16 HI-TEMP WIRE SRML BLACK
35	5'	CSO14/3	S.O. CORD 14AWG/3 CONDUCTOR
*	36	11	YAV14-H34F (STAKON) BURNDY HEAVY DUTY

* = ITEMS NOT SHOWN
 ~ = PART SOLD SEPARATELY

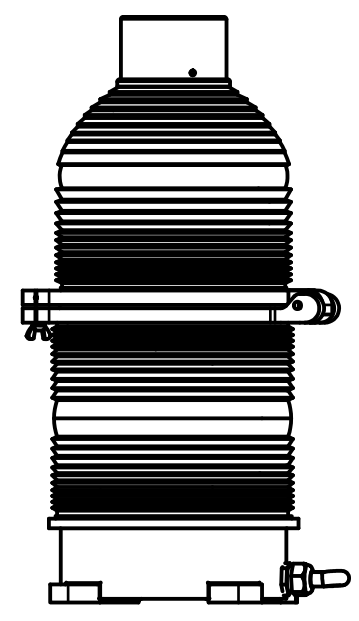

DRAWN J.L.BUSTAMANTE	11/27/07	TWR Lighting, Inc. <i>Enlightened Technology®</i>		
CHECKED				
QA		TITLE		
MFG		300 MM BEACON ASSEMBLY DETAIL		
APPROVED		SIZE B	DWG NO 275-B	REV E
		SCALE	SHEET 1 OF 1	

The use of non-OEM parts or modifications to original equipment design will void the manufacturer warranty and could invalidate the assurance of complying with FAA requirements as published in Advisory Circular 150/5345-43. NOTICE: The drawings and photographic images contained herein are the sole property of TWR Lighting, Inc. All information contained herein that is not generally known shall be considered confidential except to the extent the information has been previously established. The drawings and photographic images contained herein may not be reproduced, copied or used as the basis for manufacture or sale or promotion or any other purpose without the expressed written permission of TWR Lighting, Inc.

- 1) WHITE WIRE IS NEUTRAL TO BOTH LAMPS.
- 2) BLACK WIRE IS LINE TO BOTH LAMPS.
- 3) GREEN WIRE IS EARTH GROUND.

300 MM BEACON

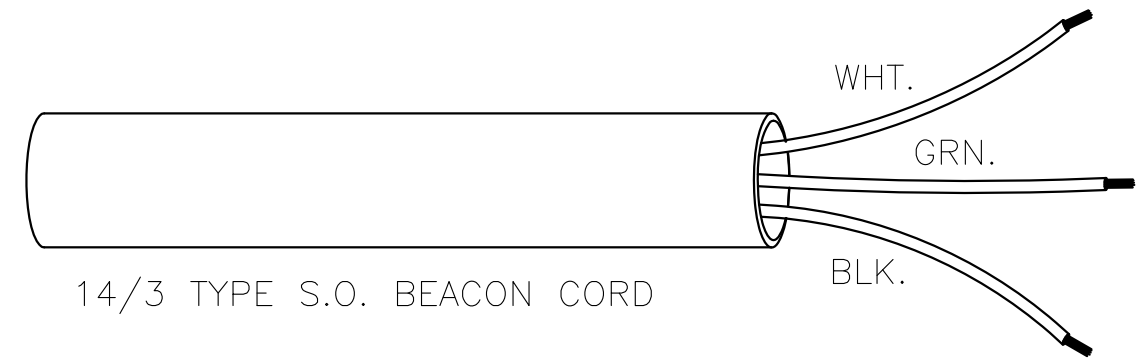
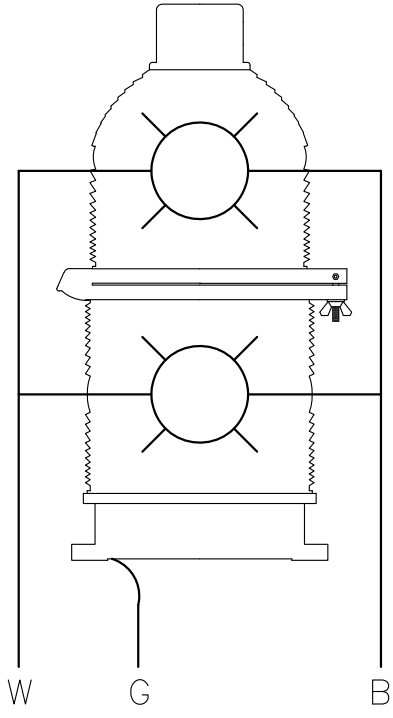

300 MM BEACON WIRE

PROD DEPT	TWR Lighting, Inc. <i>Enlightened Technology®</i>				
SERV DEPT					
ENGINEER					
DRAWN BY	G.D. SEBEK	SHEET SIZE	B	SHEET QTY.	1 OF 1
DATE	6/10/91	SCALE	N.T.S.	DWG. NO.	273-B

The use of non-OEM parts or modifications to original equipment design will void the manufacturer warranty and could invalidate the assurance of complying with FAA requirements as published in Advisory Circular 150/5345-43.
 NOTICE: The drawings and photographic images contained herein are the sole property of TWR Lighting, Inc. All information contained herein that is not generally known shall be considered confidential except to the extent the information has been previously established. The drawings and photographic images contained herein may not be reproduced, copied or used as the basis for manufacture or sale or promotion or any other purpose without the expressed written permission of TWR Lighting, Inc.

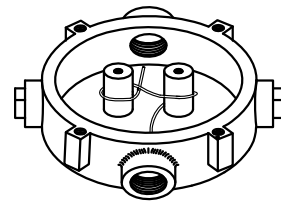
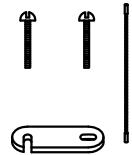
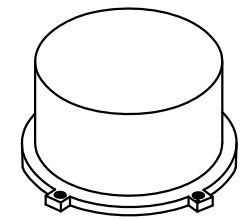
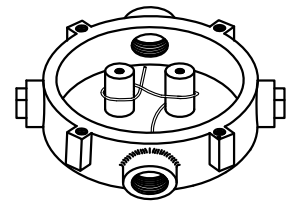
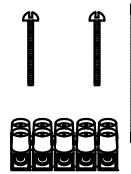
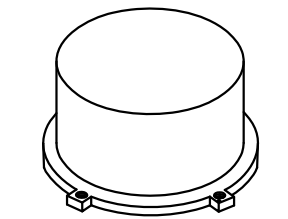

JB-5 AND JB-0
3/4" JUNCTION BOX

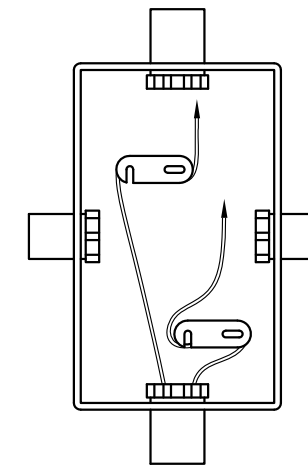
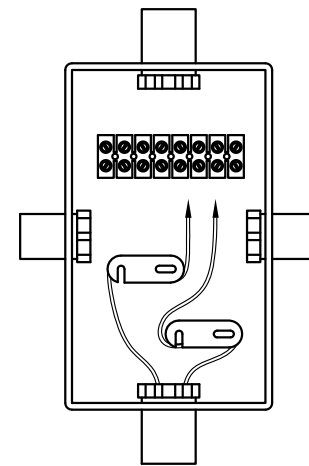

JB-8 AND JB-8SR
1" JUNCTION BOX

NOTES:

- 1) DRAWING ILLUSTRATES METHOD OF STRAIN RELIEVING WIRE. USE THIS METHOD ON ALL JUNCTION BOXES.
- 2) THE NATIONAL ELECTRICAL CODE-ARTICLE 300-19-B3 REQUIRES CONDUCTORS IN A VERTICAL CONDUIT BE SUPPORTED TO RELIEVE STRAIN ON TERMINAL BLOCK CONNECTIONS.
- 3) SKETCH ILLUSTRATES METHOD OF STRAIN RELIEVING A SINGLE CONDUCTOR. SEVERAL CONDUCTORS MAY BE GROUPED TOGETHER.
- 4) CONDUCTORS MAY BE MIXED BUT SHOULD NOT TAKE UP MORE THAN 40% OF CONDUIT'S INSIDE AREA.

USING THIS JUNCTION BOX METHOD SPACING IS 100 FEET MAXIMUM.

AWG WIRE SIZE	MAX. NUMBER WIRES IN 3/4" CONDUIT	MAX. NUMBER WIRES IN 1" CONDUIT	WIRE AREA SQ. INCHES	WEIGHT PER 100 FEET
12 THHN	16	26	0.0117	2.50
10 THHN	10	17	0.0184	4.10
8 THHN	6	9	0.0373	6.70
6 THHN	4	7	0.0519	10.30
4 THHN	2	4	0.0845	16.20

<u>JUNCTION AND STRAIN RELIEF BOXES</u>					
PROD DEPT	TWR Lighting, Inc. <i>Enlightened Technology®</i>				
SERV DEPT					
ENGINEER					
DRAWN BY	G.D. SEBEK	SHEET SIZE	B	SHEET QTY.	1 OF 1
DATE	07/26/93	SCALE	N.T.S.	DWG. NO.	100089

9/29/00	(A)	UPDATED NOTES
DATE:	LTR.	REVISION

The use of non-OEM parts or modifications to original equipment design will void the manufacturer warranty and could invalidate the assurance of complying with FAA requirements as published in Advisory Circular 150/5345-43.
NOTICE: The drawings and photographic images contained herein are the sole property of TWR Lighting, Inc. All information contained herein that is not generally known shall be considered confidential except to the extent the information has been previously established. The drawings and photographic images contained herein may not be reproduced, copied or used as the basis for manufacture or sale or promotion or any other purpose without the expressed written permission of TWR Lighting, Inc.

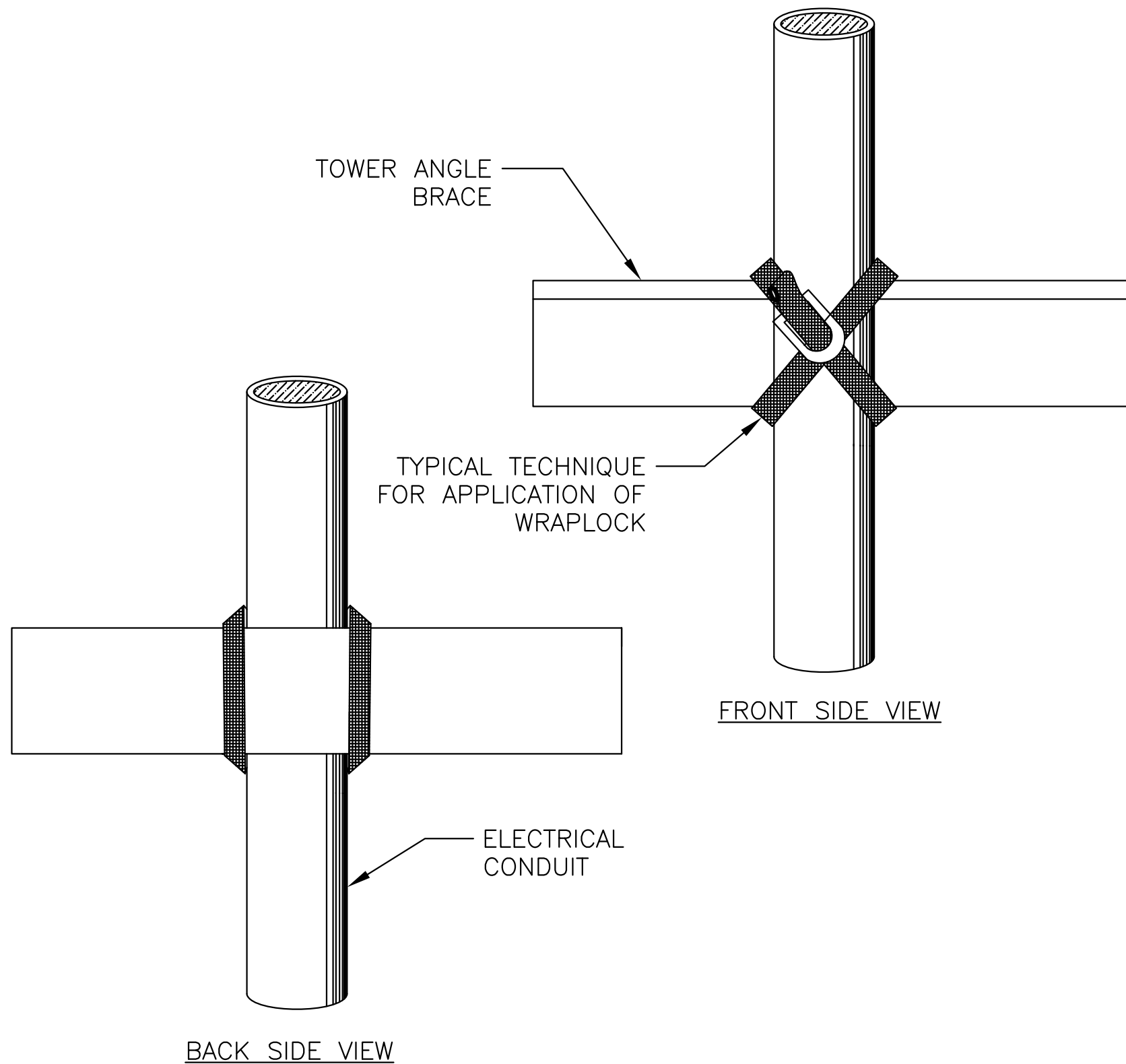

DIRECTIONS FOR USING WrapLock

CUT OFF BAND TO PROPER LENGTH.
(SEE TABLE ON COVER OF BOX)

- 1.— PASS ONE END THROUGH YOKE AND BEND BACK ABOUT 1 1/2" AND FLATTEN DOWN.
- 2.— PASS BAND AROUND WORK AND THROUGH YOKE.
- 3.— REPEAT AND PASS END THROUGH A SECOND TIME, DRAW UP FREE END SNUGLY WITH PLIERS.



TO REMOVE WrapLock
UNCOIL END WITH RATCHET. PRESS DOWN AT POINT WHERE BAND METAL HAS BEEN FORCED THROUGH CURVED PART OF YOKE.

WRAPLOCK FASTENING DETAIL

ENGINEER	TWR Lighting, Inc. <i>Enlightened Technology®</i>		
APPROVED			
APPROVED			
APPROVED	DRAWN BY M. PETERMAN	SHEET SIZE B	SHEET QTY. 1 OF 1
APPROVED	DATE 05/01/2014	SCALE N.T.S.	DWG. NO. 100984

The use of non-OEM parts or modifications to original equipment design will void the manufacturer warranty and could invalidate the assurance of complying with FAA requirements as published in Advisory Circular 150/5345-43.
NOTICE: The drawings and photographic images contained herein are the sole property of TWR Lighting, Inc. All information contained herein that is not generally known shall be considered confidential except to the extent the information has been previously established. The drawings and photographic images contained herein may not be reproduced, copied or used as the basis for manufacture or sale or promotion or any other purpose without the expressed written permission of TWR Lighting, Inc.