

# **TWR Lighting, Inc.** **HARK**<sup>®</sup>

*Enlightened Technology*<sup>®</sup>

10810 W. LITTLE YORK RD. STE. 130 - HOUSTON, TX 77041-4051  
VOICE (713) 973-6905 - FAX (713) 973-9352  
web: [www.twrlighting.com](http://www.twrlighting.com)

## **IMPORTANT!!!**

**PLEASE TAKE THE TIME TO FILL OUT THIS FORM COMPLETELY. FILE IT IN A SAFE PLACE. IN THE EVENT YOU EXPERIENCE PROBLEMS WITH OR HAVE QUESTIONS CONCERNING YOUR CONTROLLER, THE FOLLOWING INFORMATION IS NECESSARY TO OBTAIN PROPER SERVICE AND PARTS.**

MODEL # AA2/3MLED

SERIAL # \_\_\_\_\_

PURCHASE DATE \_\_\_\_\_

PURCHASED FROM \_\_\_\_\_

# **TWR Lighting, Inc.** **MARK**

*Enlightened Technology*

## **AA2/3MLED CONTROLLER**

---

### **TABLE OF CONTENTS**

<b>1.0</b>	<b>GENERAL INFORMATION.....</b>	<b>1</b>
<b>2.0</b>	<b>INSTALLATION INSTRUCTIONS .....</b>	<b>2</b>
2.1	<b>MOUNTING THE CONTROL CABINET.....</b>	<b>2</b>
2.2	<b>EXTERNAL PHOTOCELL WIRING .....</b>	<b>2</b>
2.3	<b>POWER WIRING.....</b>	<b>3</b>
2.4	<b>LED BEACONS AND LED SIDELIGHTS WIRING .....</b>	<b>3</b>
2.5	<b>LED BEACONS AND LED SIDELIGHTS ALARM WIRING .....</b>	<b>4</b>
<b>3.0</b>	<b>THEORY OF OPERATION .....</b>	<b>6</b>
3.1	<b>POWER SUPPLY.....</b>	<b>6</b>
3.2	<b>LED SIDELIGHTS .....</b>	<b>6</b>
3.3	<b>LED BEACONS.....</b>	<b>6</b>
<b>4.0</b>	<b>MAINTENANCE .....</b>	<b>7</b>
4.1	<b>RED OBSTRUCTION LIGHTING.....</b>	<b>7</b>
4.2	<b>L-864 LED BEACON REPLACEMENT.....</b>	<b>7</b>
4.3	<b>L-864 CONTROLLER.....</b>	<b>7</b>
4.4	<b>PHOTOCELL.....</b>	<b>7</b>
<b>5.0</b>	<b>MAJOR COMPONENTS PARTS LIST .....</b>	<b>8</b>
<b>6.0</b>	<b>SUGGESTED SPARE PARTS LIST.....</b>	<b>9</b>

**WARRANTY & RETURN POLICY**

**RETURN MERCHANDISE AUTHORIZATION (RMA) FORMS**

# **TWR Lighting, Inc.** **HARK**

*Enlightened Technology*

## **AA2/3MLED CONTROLLER**

---

### **APPENDIX**

CHASSIS COMPONENT LAYOUT .....	1204-R (REV F)
SCHEMATIC LAYOUT .....	1204-S (REV G)
TROUBLESHOOTING FLOW CHART .....	1204-F
PHOTOCELL HOUSING DETAIL.....	100239 (REV H)
LK1A2/3LED TOWER LIGHTING KIT CABLE RUN 351' TO 700' ....	801-01 (REV B)
LK2A2/3LED TOWER LIGHTING KIT CABLE RUN 351' TO 700' ...	801-02 (REV C)
LED SIDELIGHT/LEDBEACON CURRENT SENSOR RELAY.....	101088 (REV B)
LED BEACON2 ASSEMBLY.....	100761 (REV C)
OL1VLED2 (L810 SINGLE OBSTRUCTION LIGHT).....	100656 (REV E)
JUNCTION AND STRAIN RELIEF BOXES.....	100089 (REV A)
WRAPLOCK FASTENING DETAIL.....	100984

# **TWR Lighting, Inc.** HARK<sup>®</sup>

*Enlightened Technology<sup>®</sup>*

## **AA2/3MLED CONTROLLER**

---

### **1.0 GENERAL INFORMATION**

The TWR Lighting<sup>®</sup>, Inc. (TWR<sup>®</sup>), Model AA2/3MLED, Controller is for A2 lighting of towers 351' to 700' above ground level (AGL) in accordance with the FAA Advisory Circular 70/7460-1K. One (1) LED beacon should be placed at the top and two (2) LED beacons at mid-level. Obstruction lights should be placed at the  $\frac{3}{4}$  and  $\frac{1}{4}$  intervals with respect to overall tower height.

The flash rate of the LED beacons is 30 per minute. The LED beacons flash synchronized to one another. The LED sidelights burn steady.

A by-pass switch (SW1) allows the controller to be turned on during daylight hours without covering the photocell. This is particularly helpful since the controller can be mounted indoors while the photocell is outdoors. SW1 can be operated by turning the switch up to "On" position.

The photocell is the three (3) blade, twist to lock, type.

Power supplied to the controller shall be 120V AC single phase.

The controller housing is rated at NEMA 4X. It is suitable for indoor or outdoor mounting.

Controller functions that are monitored by remote alarms in the form of dry contact closures (Form C) are as follows:

<b>POWER FAILURE</b>	Monitors 120V AC to the controller. Alarms in the event of power failure or tripped circuit breaker.
<b>LIGHTS "ON"</b>	Gives an indication whenever the controller is activated.
<b>LED BEACONS</b>	Will give an alarm in the event any of the LED beacons fail, along with visual indicator for that circuit.
<b>FLASHER FAILURE</b>	Will give an alarm in the event of failure of flasher.
<b>OBSTRUCTION LIGHTS</b>	Will give an alarm when one (1) of three (3) LED sidelights fails.

# **TWR Lighting, Inc.** HARK®

*Enlightened Technology®*

## **AA2/3MLED CONTROLLER**

---

### **2.0 INSTALLATION INSTRUCTIONS**

#### **2.1 MOUNTING THE CONTROL CABINET**

(Refer to Drawing 1204-R)

The power supply control cabinet can be located at the base of the structure or in an equipment building. Mounting footprints are shown on drawing 1204-R. Power wiring to the control cabinet should be in accordance with local methods and National Electrical Codes (NEC).

2.1.1 If the control cabinet is mounted inside an equipment building, the photocell should be mounted vertically on ½” conduit outside the building above the eaves facing north. Wiring from the photocell socket to the control cabinet should consist of one (1) each, red, black, and white wires. The white wire is connected to the socket terminal marked “N,” the black wire is connected to the socket terminal marked “Li,” and the red wire is connected to the socket terminal marked “Lo.” Care must be taken to assure that the photocell does not “see” any ambient light that would prevent it from switching into the nightmode.

2.1.2 If the control cabinet is mounted outside an equipment building, the photocell should be mounted vertically on ½” conduit so the photocell is above the control cabinet. As above, the photocell should be positioned so that it does not “see” ambient light, which would prevent it from switching to the nightmode. The photocell wiring is the same as in 2.1.1.

2.1.3 The wiring from the photocell, the service breaker, the red incandescent beacons, and the sidelights should enter the control cabinet through the watertight connectors in the bottom of the cabinet. Inside the cabinet, the connections will be made on the terminal strips and circuit breakers located at the bottom of the chassis. These connections are made as follows:

#### **2.2 EXTERNAL PHOTOCCELL WIRING**

(Refer to Drawing 1204-R)

2.2.1 Connect the **BLACK** wire from the photocell to terminal block TB2 marked “L.”

## **AA2/3MLED CONTROLLER**

---

2.2.2 Connect the **RED** wire from the photocell to terminal block TB2 marked “SSR.”

2.2.3 Connect the **WHITE** wire from the photocell to terminal block TB2 marked “N.”

### **2.3 POWER WIRING**

(Refer to Drawing 1204-R)

2.3.1 Power wiring to the control cabinet should be in accordance with local methods and National Electrical Codes.

2.3.2 Circuit breaker needs to be a one (1) pole common trip rated at 10 amps.

2.3.3 Connect incoming 120V AC “Hot” to terminal block TB1 marked “L.”

2.3.4 Connect the neutral wire(s) to one (1) of the terminal blocks on TB1 marked “N.”

2.3.5 Connect the AC ground to the aluminum mounting plate.

### **2.4 LED BEACONS AND LED SIDELIGHTS WIRING**

(Refer to Drawings 1204-R, 801-01, or 801-02)

2.4.1 Connect the **BLACK** wire from LED Beacon #1 to the circuit breaker marked “B1.”

2.4.2 Connect the **BLUE** wire from LED Beacon #2 and LED Beacon #3 to the circuit breaker marked “B2-B3.”

2.4.3 Connect the **RED** wire from LED sidelight group #1 to the circuit breaker marked “S1.”

2.4.4 Connect the **YELLOW** wire from LED sidelight group #2 to the circuit breaker marked “S2.”

2.4.5 Connect the **WHITE** neutral wire(s) to one (1) or more of the terminals marked “N.”

## **AA2/3MLED CONTROLLER**

---

2.4.6 Connect the ground wires to the ground lug located to the left of "TB2."

### **2.5 LED BEACONS AND LED SIDELIGHTS ALARM WIRING**

(Refer to Drawings 1204-R and 1204-S)

2.5.1 Alarm relays K1-K3, and alarm Modules M2-M5, are provided for independent contact closures for: Power Failure, Lights "On," Flasher Failure, B1 Burnout, B2-B3 Burnout, S1 Lamp Burnout, and S2 Lamp Burnout.

2.5.2 Alarm Wiring: To utilize all of the red light alarms, the customer will need seven (7) pairs of wires to interface with his alarm device. One (1) wire from each of the seven (7) pairs will terminate at the points marking common (C). The remaining wire from each pair will terminate as follows:

**Power Failure Alarm:** Connect to relay K1, terminal #3, for normally open (OR) terminal #6, for normally closed monitoring.

**Lights "On" Alarm:** Connect to relay K2, terminal #3, for normally open (OR) terminal #6, for normally closed monitoring.

**Flasher Failure:** Connect to relay K3, terminal #6, for normally open (OR) terminal #3, for normally closed monitoring.

**B1 Burnout:** Connect to module M4, terminal #24, for normally open (OR) terminal #22, for normally closed monitoring.

**B2 and B3 Burnout:** Connect to module M5, terminal #24, for normally open (OR) terminal #22, for normally closed monitoring.

**S1 Lamp Burnout:** Connect to module M2, terminal #24, for normally open (OR) terminal #22, for normally closed monitoring.

# **TWR Lighting, Inc.** HARK<sup>®</sup>

*Enlightened Technology<sup>®</sup>*

## **AA2/3MLED CONTROLLER**

---

- S2 Lamp Burnout:** Connect to module M3, terminal #24, for normally open ( OR) terminal #22, for normally closed monitoring.
- 2.5.3 Alarm Testing: To test alarms, follow the procedures using an “ohm” meter between alarm common and alarm points.
- Power Failure:** Pull circuit breaker at electrical panel.
- Lights “On”:** Operate photocell by-pass switch SW1 or cover the photocell.
- LED Beacons and LED Sidelights:**  
Trip breakers on the controller panel.



# **TWR Lighting, Inc.** HARK®

*Enlightened Technology®*

## **AA2/3MLED CONTROLLER**

---

### **3.0 THEORY OF OPERATION**

#### **3.1 POWER SUPPLY**

120V AC enters the controller from the circuit breaker panel. Line “L” sits at the PRD, waiting to be switched, and also keeps the power failure relay K1 energized. When the 6390-FAA photocell is activated, Line “SSR” energizes the coil of the PRD and K2 “Lights On” relay. This also can be accomplished by using the photocell by-pass switch (SW1).

#### **3.2 LED SIDELIGHTS**

Line LDS is sent to Modules M2 and M3, which are current sensing modules for LED sidelights. Each RM22JA31MR monitors one (1) level of LED sidelights, and will provide a contact closure along with a visual indication if one (1) or more lamps fail.

#### **3.3 LED BEACONS**

Line LDB is sent to Modules M1, M4, and M5. M1 is the primary flasher for all of the LED beacons. The output of this module is sent through the current sensing Modules M4, and M5, then to the circuit breaker outputs B1, and B2-B3. If Modules M4, or M5, detect an LED beacon burnout, then that particular module would provide a contact closure along with a visual indication for that circuit.

Relay K3 is a flasher failure relay for all the LED beacons. If Relay K3 detects a flasher failure, it would then provide a contact closure for the flasher circuit.

# **TWR Lighting, Inc.** HARK<sup>®</sup>

*Enlightened Technology<sup>®</sup>*

## **AA2/3MLED CONTROLLER**

---

### **4.0 MAINTENANCE**

#### **4.1 RED OBSTRUCTION LIGHTING**

No scheduled maintenance is required. Perform on an “as needed” basis only.

TOOLS REQUIRED: NONE

#### **4.2 L-864 LED BEACON REPLACEMENT**

No scheduled maintenance is required. Perform on an “as needed” basis only.

#### **4.3 L-864 CONTROLLER**

No scheduled maintenance is required. Perform on an “as needed” basis only.

#### **4.4 PHOTOCELL**

The photocell is a sealed unit. No maintenance is needed or required other than replacement as necessary.

# TWR Lighting, Inc. HARK®

Enlightened Technology®

## AA2/3MLED CONTROLLER

### 5.0 MAJOR COMPONENTS PARTS LIST

QTY	PART NUMBER	DESCRIPTION
1	6390-FAA (This replaces the 102-FAA Photocell)	120 – 240V Photocell
1	PF-250 (This replaces the FS155-30T Module)	Solid State Flasher (M1)
1	STA08015	3,500 ohm 20 watt Resistor (R1)(rev-6/21)
1	PRD7AG0	Mechanical Load Contactor (PRD)
3	PB27E122	Octal Sockets
2	KRPA5AG120V	SPDT Relay (K1 & K2)
1	SPEC 224	Time Delay Relay (K3)
1	STJ01002	Switch (SW1)
1	VJ1412HWPL2	Enclosure
6	8WA1204	Terminal Block (TB1 & TB2)
2	8WA1802	Rail Link
2	8WA1808	Terminal Block End Stop
1	S261D2	2 amp Circuit Breaker (B2-B3)
4	RM22JA31MRSP01	LED Sidelight Current Sensors (M2, and M3), and LED Beacon Current Sensors (M4, and M5)
3	S261D1	1 amp Circuit Breakers (B1, S1-S2)

## **AA2/3MLED CONTROLLER**

---

### **6.0 SUGGESTED SPARE PARTS LIST**

<b>QTY</b>	<b>PART NUMBER</b>	<b>DESCRIPTION</b>
1	6390-FAA (This replaces the 102-FAA Photocell)	120 – 240V Photocell
1	PF-250 (This replaces the FS155-30T Module)	Solid State Flasher (M1)
1	KRPA5AG120V	SPDT Relay (K1 & K2)
1	SPEC 224	Time Delay Relay (K3)
1	RM22JA31MRSP01	LED Sidelight Current Sensors (M2, and M3), and LED Beacon Current Sensors (M4, and M5)

# **TWR Lighting, Inc.** **MARK**

*Enlightened Technology*

## **AA2/3MLED CONTROLLER**

---

### **Warranty & Return Policy**

**TWR Lighting**, Inc. (“**TWR**”) warrants its products (other than “**LED Product**”) against defects in design, material (excluding incandescent bulbs) and workmanship for a period ending on the earlier of two (2) years from the date of shipment or one (1) year from the date of installation.

**TWR Lighting**, Inc. (“**TWR**”) warrants its “**LED Product**” against defects in design, material and workmanship for a period of five (5) years from the date of shipment. **TWR**, at its sole option, will, itself, or through others, repair, replace or refund the purchase price paid for “**LED Product**” that **TWR** verifies as being inoperable due to original design, material, or workmanship. All warranty replacement “**LED Product**” is warranted only for the remainder of the original warranty of the “**LED Product**” replaced. Replacement “**LED Product**” will be equivalent in function, but not necessarily identical, to the replaced “**LED Product**.”

**TWR Lighting**, Inc. (“**TWR**”) warrants its “**LED Product**” against light degradation for a period of five (5) years from the date of installation. **TWR**, at its sole option, will, itself, or through others, repair, replace, or refund the purchase price paid for “**LED Product**” that **TWR** verifies as failing to meet 75% of the minimum intensity requirements as defined in the FAA Advisory Circular 150/5345-43G dated 09/26/12. All warranty replacement “**LED Product**” is warranted only for the remainder of the original warranty of the “**LED Product**” replaced. Replacement “**LED Product**” will be equivalent in function, but not necessarily identical, to the replaced “**LED Product**.”

**Replacement parts (other than “LED Product”) are warranted for 90 days from the date of shipment.**

Conditions not covered by this Warranty, or which might void this Warranty are as follows:

- x Improper Installation or Operation
- x Misuse
- x Abuse
- x Unauthorized or Improper Repair or Alteration
- x Accident or Negligence in Use, Storage, Transportation, or Handling
- x Any Acts of God or Nature
- x **Non-OEM Parts**

**The use of Non-OEM parts or modifications to original equipment design will void the manufacturer warranty and could invalidate the assurance of complying with FAA requirements as published in Advisory Circular 150/5345-43.**

# **TWR Lighting, Inc.** HARK®

*Enlightened Technology®*

## **AA2/3MLED CONTROLLER**

---

### **Warranty & Return Policy** (continued)

**Field Service** – Labor, Travel, and Tower Climb are not covered under warranty. Customer shall be obligated to pay for all incurred charges. An extensive network of certified and insured Service Representatives is available if requested.

**Repair, Replacement or Product Return RMA Terms** – You must first contact our Customer Service Department at **713-973-6905** to acquire a Return Merchandise Authorization (RMA) number in order to return the product(s). Please have the following information available when requesting an RMA number:

- x The contact name and phone number of the tower owner or
- x The contact name and phone number of the contractor
- x The site name and number
- x The part number(s)
- x The serial number(s) (if any)
- x A description of the problem
- x The billing information
- x The Ship To address

**This RMA number must be clearly visible on the outside of the box.** If the RMA number is not clearly labeled on the outside of the box, your shipment will be refused. Please ensure the material you are returning is packaged carefully. **The warranty is null and void if the product(s) are damaged in the return shipment.**

**All RMAs must be received by TWR LIGHTING®, INC., 10810 W. LITTLE YORK RD. #130, HOUSTON, TX 77041-4051, within 30 days of issuance.**

Upon full compliance with the Return Terms, TWR® will replace, repair and return, or credit product(s) returned by the customer. It is TWR®'s sole discretion to determine the disposition of the returned item(s).

# **TWR Lighting, Inc.** HARK®

*Enlightened Technology®*

## **AA2/3MLED CONTROLLER**

---

### **Warranty & Return Policy** (continued)

**RMA Replacements** – Replacement part(s) will be shipped and billed to the customer for product(s) considered as Warranty, pending return of defective product(s). When available, a certified reconditioned part is shipped as warranty replacement with a Return Merchandise Authorization (RMA) number attached. Upon receipt of returned product(s), inspection, testing, and evaluation will be performed to determine the cause of defect. The customer is then notified of the determination of the testing.

- x Product(s) that is deemed defective and/or unrepairable and covered under warranty - a credit will be issued to the customer's account.
- x Product(s) found to have no defect will be subject to a **\$75.00 per hour testing charge (1 hour minimum), which will be invoiced to the customer.** At this time the customer may decide to have the tested part(s) returned and is responsible for the return charges.
- x Product(s) under warranty, which the customer does not wish returned, the customer will be issued a credit against the replacement invoice.

**RMA Repair & Return** – A Return Merchandise Authorization (RMA) will be issued for all part(s) returned to TWR® for repair. Upon receipt of returned product(s), inspection, testing, and evaluation will be performed to determine the cause of defect. The customer is then notified of the determination of the testing. If the returned part(s) is deemed unrepairable, or the returned part(s) is found to have no defect, the customer will be subject to a **\$75.00 per hour testing charge (1 hour minimum), which will be invoiced to the customer.** Should the returned parts be determined to be repairable, a written estimated cost of repair will be sent to the customer for their written approval prior to any work being performed. In order to have the tested part(s) repaired and/or returned, the customer must issue a purchase order and is responsible for the return shipping charges.

**RMA Return to Stock** – Any product order that is returned to TWR® for part(s) ordered incorrectly or found to be unneeded upon receipt by the customer, the customer may be required to pay a minimum **20% restocking fee.** Product returned for credit must be returned within 60-days of original purchase, be in new and resalable condition, and in original packaging. Once the product is received by TWR it's condition will be evaluated and a credit will be issued only once it is determined that the RMA Return Terms have been met.

**Credits** – Credits are issued once it is determined that all of the Warranty and Return Terms are met. All credits are processed on Fridays. In the event a Friday falls on a Holiday, the credit will be issued on the following Friday.

# **TWR Lighting, Inc.** **HARK**

*Enlightened Technology*

## **AA2/3MLED CONTROLLER**

---

### **Warranty & Return Policy** (continued)

**Freight** – All warranty replacement part(s) will be shipped via ground delivery and paid for by TWR®. Delivery other than ground is the responsibility of the customer.

REMEDIES UNDER THIS WARRANTY ARE LIMITED TO PROVISIONS OF REPLACEMENT PARTS AND REPAIRS AS SPECIFICALLY PROVIDED. IN NO EVENT SHALL TWR® BE LIABLE FOR ANY OTHER LOSSES, DAMAGES, COSTS, OR EXPENSES INCURRED BY THE CUSTOMER, INCLUDING, BUT NOT LIMITED TO, LOSS FROM FAILURE OF THE PRODUCT(S) TO OPERATE FOR ANY TIME, AND ALL OTHER DIRECT, INDIRECT, SPECIAL, INCIDENTAL, OR CONSEQUENTIAL DAMAGES, INCLUDING ALL PERSONAL INJURY OR PROPERTY DAMAGE DUE TO ALLEGED NEGLIGENCE, OR ANY OTHER LEGAL THEORY WHATSOEVER. THIS WARRANTY IS MADE BY TWR® EXPRESSLY IN LIEU OF ALL OTHER WARRANTIES, WHETHER EXPRESSED OR IMPLIED. WITHOUT LIMITING THE GENERALITY OF THE FORGOING, TWR® MAKES NO WARRANTY OF MERCHANTABILITY OR FITNESS OF THE PRODUCT(S) FOR ANY PARTICULAR PURPOSE. TWR® EXPRESSLY DISCLAIMS ALL OTHER WARRANTIES.



# **TWR Lighting, Inc.** HARK<sup>®</sup>

*Enlightened Technology<sup>®</sup>*

**AA2/3MLED CONTROLLER**

---

---

## **RETURN MERCHANDISE AUTHORIZATION (RMA) FORM**

**RMA#:** \_\_\_\_\_ **DATE:** \_\_\_\_\_

**CUSTOMER:** \_\_\_\_\_

---

**CONTACT:** \_\_\_\_\_ **PHONE NO.:** \_\_\_\_\_

**ITEM DESCRIPTION (PART NO.):** \_\_\_\_\_

---

**MODEL NO.:** \_\_\_\_\_ **SERIAL NO.:** \_\_\_\_\_

**ORIGINAL TWR INVOICE NO.:** \_\_\_\_\_ **DATED:** \_\_\_\_\_

**DESCRIPTION OF PROBLEM:** \_\_\_\_\_

---

---

---

**SIGNED** \_\_\_\_\_ **DATE NEEDED** \_\_\_\_\_

**RETURN ADDRESS:** \_\_\_\_\_

---

PLEASE RETURN PRODUCT TO: 10810 W. LITTLE YORK RD. #130 HOUSTON, TX 77041-4051

# **TWR Lighting, Inc.** HARK<sup>®</sup>

*Enlightened Technology<sup>®</sup>*

**AA2/3MLED CONTROLLER**

---

---

## **RETURN MERCHANDISE AUTHORIZATION (RMA) FORM**

**RMA#:** \_\_\_\_\_ **DATE:** \_\_\_\_\_

**CUSTOMER:** \_\_\_\_\_

---

**CONTACT:** \_\_\_\_\_ **PHONE NO.:** \_\_\_\_\_

**ITEM DESCRIPTION (PART NO.):** \_\_\_\_\_

---

**MODEL NO.:** \_\_\_\_\_ **SERIAL NO.:** \_\_\_\_\_

**ORIGINAL TWR INVOICE NO.:** \_\_\_\_\_ **DATED:** \_\_\_\_\_

**DESCRIPTION OF PROBLEM:** \_\_\_\_\_

---

---

---

**SIGNED** \_\_\_\_\_ **DATE NEEDED** \_\_\_\_\_

**RETURN ADDRESS:** \_\_\_\_\_

---

PLEASE RETURN PRODUCT TO: 10810 W. LITTLE YORK RD. #130 HOUSTON, TX 77041-4051

**\*CUSTOMER ALARM POINTS**

- C = ALARM COMMON
- PFNO/PFNC = POWER FAILURE
- LONO/LONC = LIGHTS "ON"
- FFNO/FFNC = FLASHER FAILURE
- S1NO/S1NC = TOP LEVEL LED SIDELIGHT BURNOUT
- S2NO/S2NC = LOWER LEVEL LED SIDELIGHT BURNOUT
- B1NO/B1NC = TOP LEVEL LED BEACON BURNOUT
- B2NO/B2NC = MID LEVEL LED BEACON BURNOUT
- B3NO/B3NC = MID LEVEL LED BEACON BURNOUT
- \* ALARM OUTPUTS ARE FORM C.

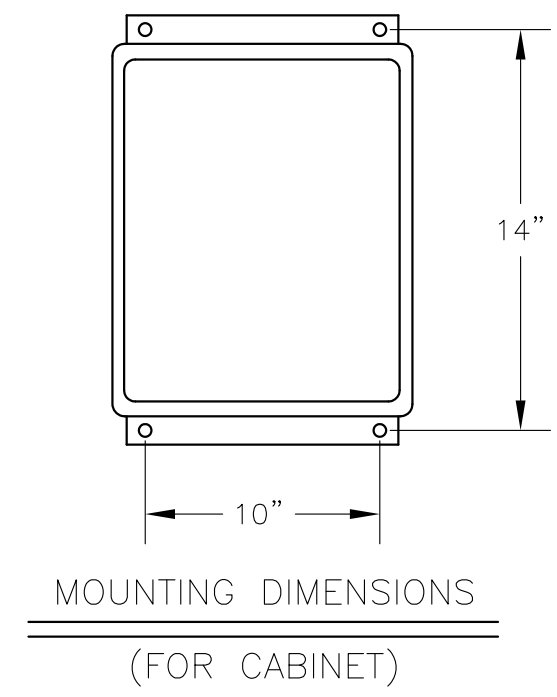
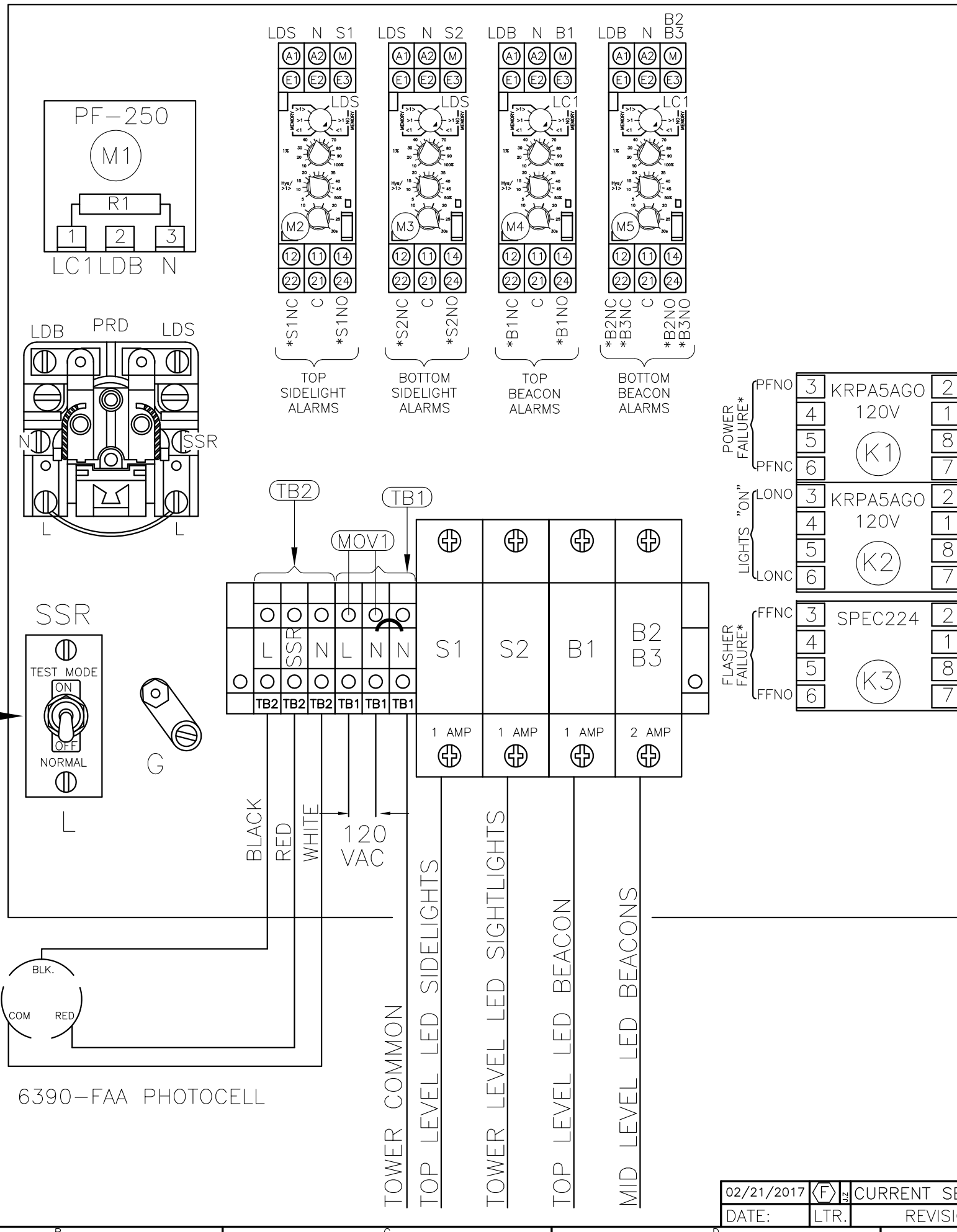

- NOTES:
1. WHEN REPLACING METAL BASE MODULES USE HEAT SINK COMPOUND BETWEEN MODULE AND ALUMINUM PLATE.
  2. PLUG 6390-FAA PHOTOCELL INTO 43109 TWIST LOCK RECEPTACLE AND TWIST TO LOCK.

AA2/3MLED CONTROLLER CHASSIS LAYOUT			
120V 50/60 Hz			
PROD DEPT	<b>TWR Lighting, Inc.</b> <i>Enlightened Technology</i> <b>WARK</b>		
SERV DEPT			
ENGINEER			
DRAWN BY	E.A.SALAZAR	SHEET SIZE	SHEET QTY.
DATE	09/16/04	B	1 OF 1
SCALE	N.T.S.	DWG. NO.	1204-R

02/21/2017	(F)	CURRENT SENSOR
DATE:	LTR.	REVISION

The use of non-OEM parts or modifications to original equipment design will void the manufacturer warranty and could invalidate the assurance of complying with FAA requirements as published in Advisory Circular 150/5345-43.  
NOTICE: The drawings and photographic images contained herein are the sole property of TWR Lighting, Inc. All information contained herein that is not generally known shall be considered confidential except to the extent the information has been previously established. The drawings and photographic images contained herein may not be reproduced, copied or used as the basis for manufacture or sale or promotion or any other purpose without the expressed written permission of TWR Lighting, Inc.

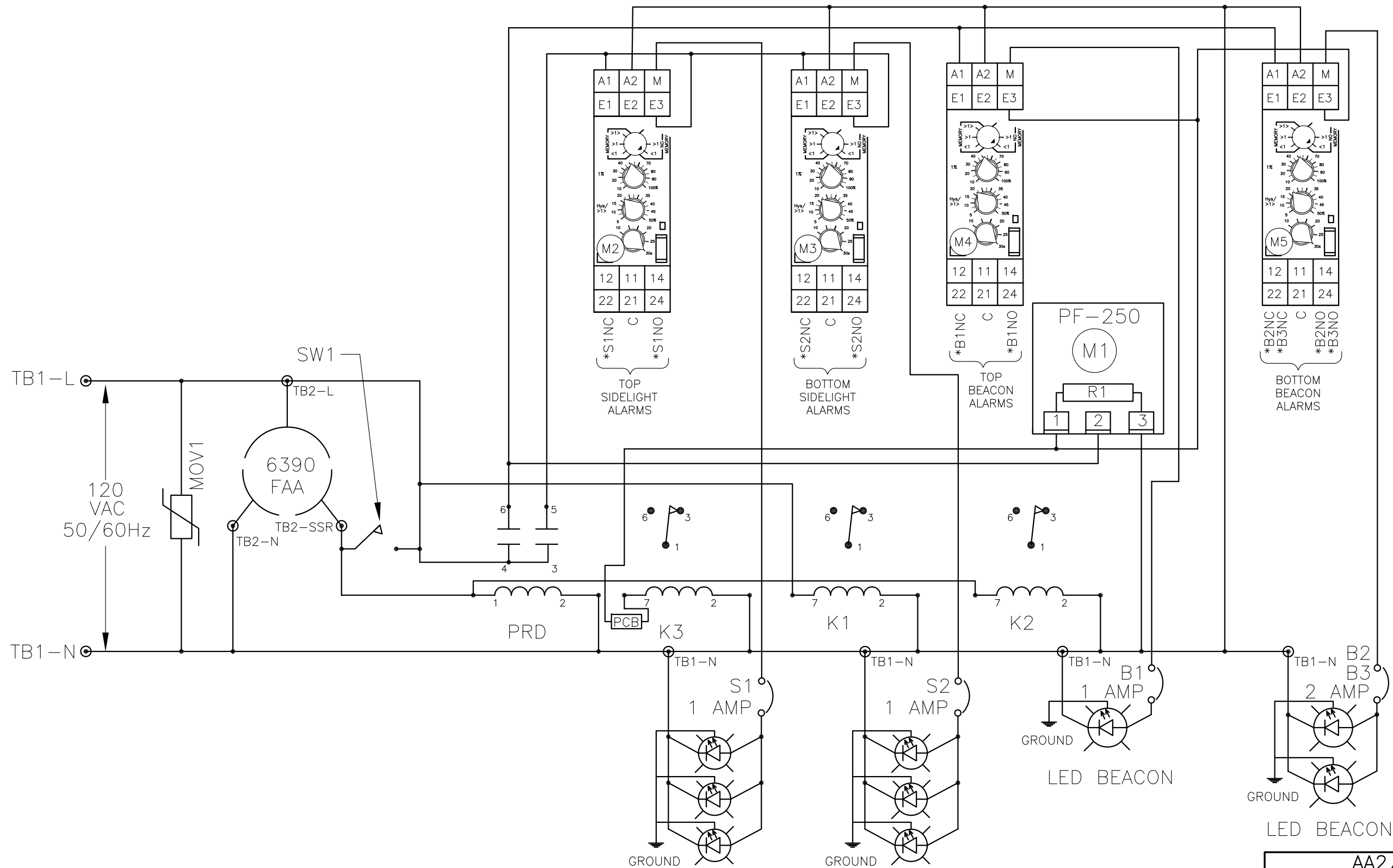

LED SIDELIGHTS

LED BEACON

LED BEACONS

**AA2/3M LED CONTROLLER  
SCHEMATIC LAYOUT**

PROD DEPT	<b>TWR Lighting, Inc.</b> <i>Enlightened Technology</i> <b>WARK</b>		
SERV DEPT			
ENGINEER			
DRAWN BY	E.A.SALAZAR	SHEET SIZE	SHEET QTY.
DATE	09/17/04	SCALE	N.T.S.
		DWG. NO.	1204-S

02/21/2017		JZ	CURRENT SENSOR
DATE:	LTR.		REVISION

The use of non-OEM parts or modifications to original equipment design will void the manufacturer warranty and could invalidate the assurance of complying with FAA requirements as published in Advisory Circular 150/5345-43.  
 NOTICE: The drawings and photographic images contained herein are the sole property of TWR Lighting, Inc. All information contained herein that is not generally known shall be considered confidential except to the extent the information has been previously established. The drawings and photographic images contained herein may not be reproduced, copied or used as the basis for manufacture or sale or promotion or any other purpose without the expressed written permission of TWR Lighting, Inc.

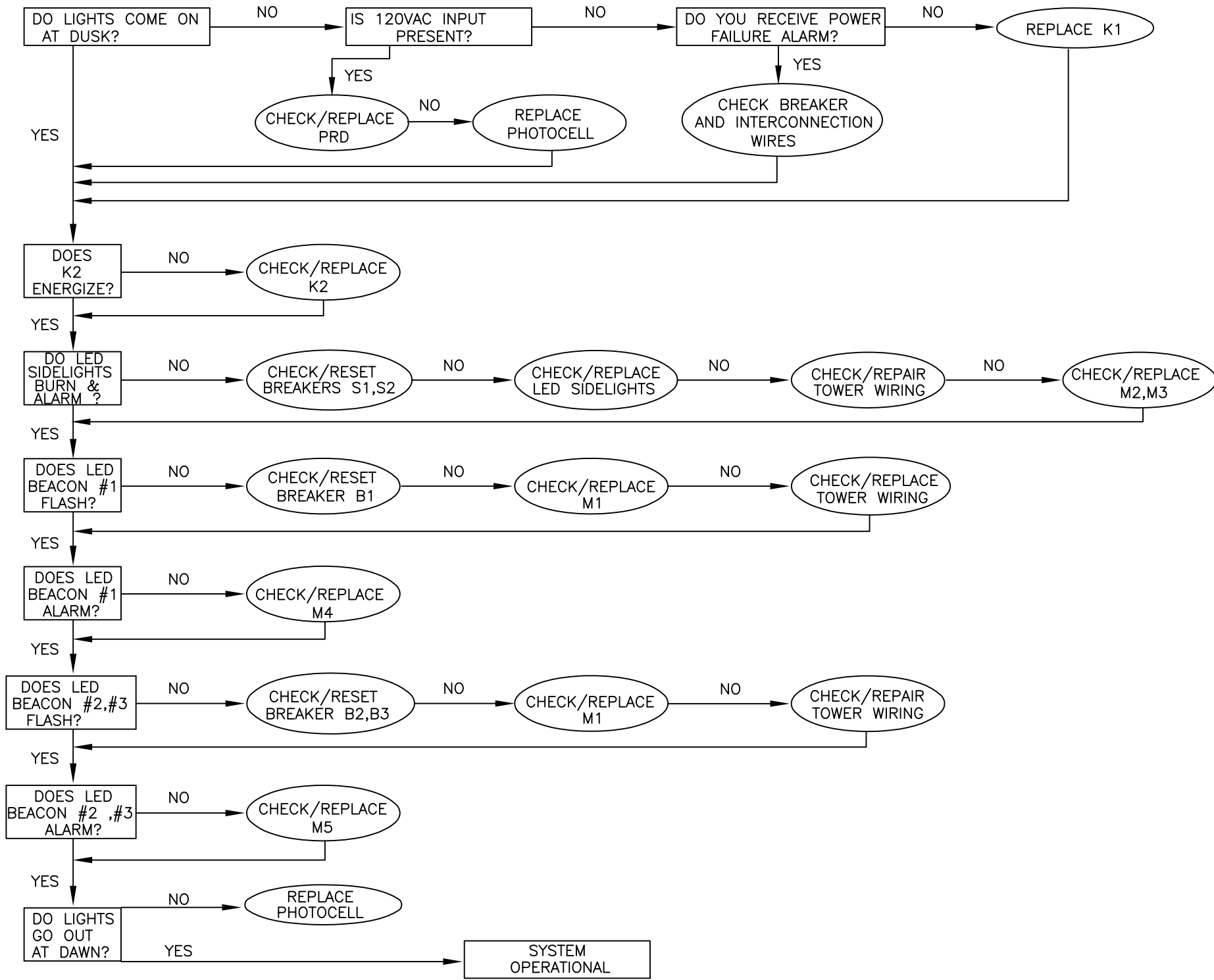

<b>TROUBLESHOOTING FLOW CHART</b>			
<b>AA2/3MLED 50/60HZ DWG.#1204-R</b>			
PROD DEPT	<b>TWR Lighting, Inc.</b> <i>Enlightened Technology®</i>		
SERV DEPT			
ENGINEER			
DRAWN BY E.A.SALAZAR	SHEET SIZE B	SHEET QTY. 1 OF 1	
DATE 09/17/04	SCALE N.T.S.	DWG. NO. 1204-F	
<small>           The use of non-OEM parts or modifications to original equipment design will void the manufacturer warranty and could invalidate the assurance of complying with FAA requirements as published in Advisory Circular 150/5345-43.            NOTICE: The drawings and photographic images contained herein are the sole property of TWR Lighting, Inc. All information contained herein that is not generally known shall be considered confidential except to the extent the information has been previously established. The drawings and photographic images contained herein may not be reproduced, copied or used as the basis for manufacture or sale or promotion or any other purpose without the expressed written permission of TWR Lighting, Inc.         </small>			

4

3

2

1

PARTS LIST		
ITEM	QTY	PART NUMBER
1	1	PHOTOCELL
2	2	6-32 x 1" SCREW
3	1	RECEPTACLE SOCKET
4	1	RECEPTACLE GASKET
5	1	RECEPTACLE HOUSING
6	1	1/2" CONDUIT LOCKNUT
7	1	3/4" TO 1/2" REDUCER

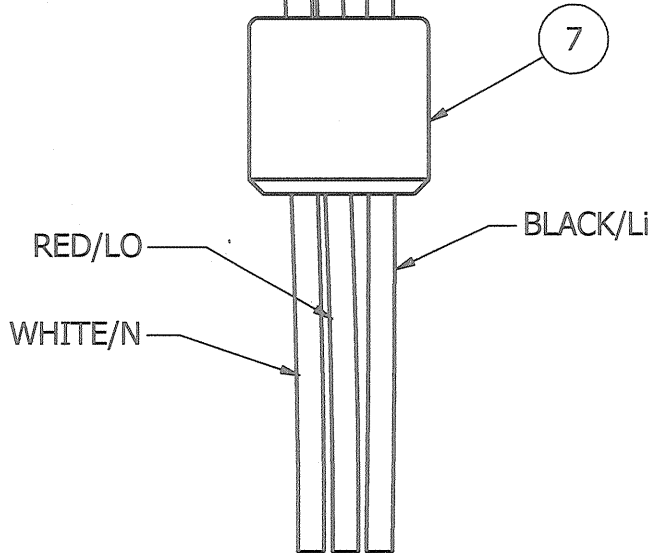
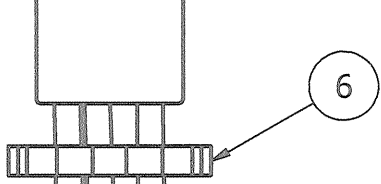
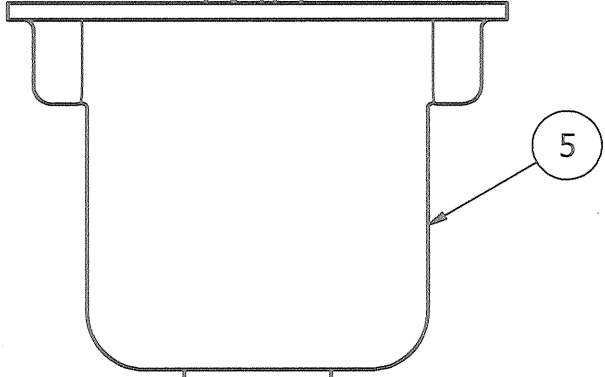
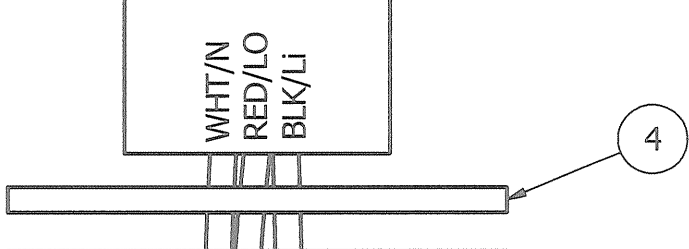
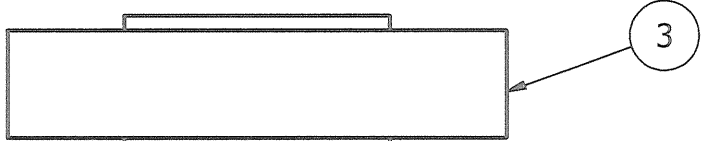
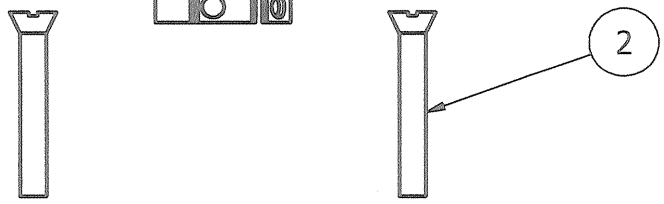
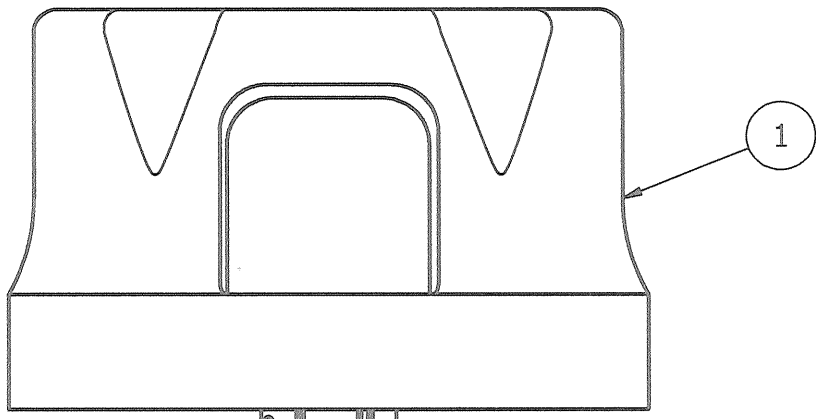

EXPLODED VIEW

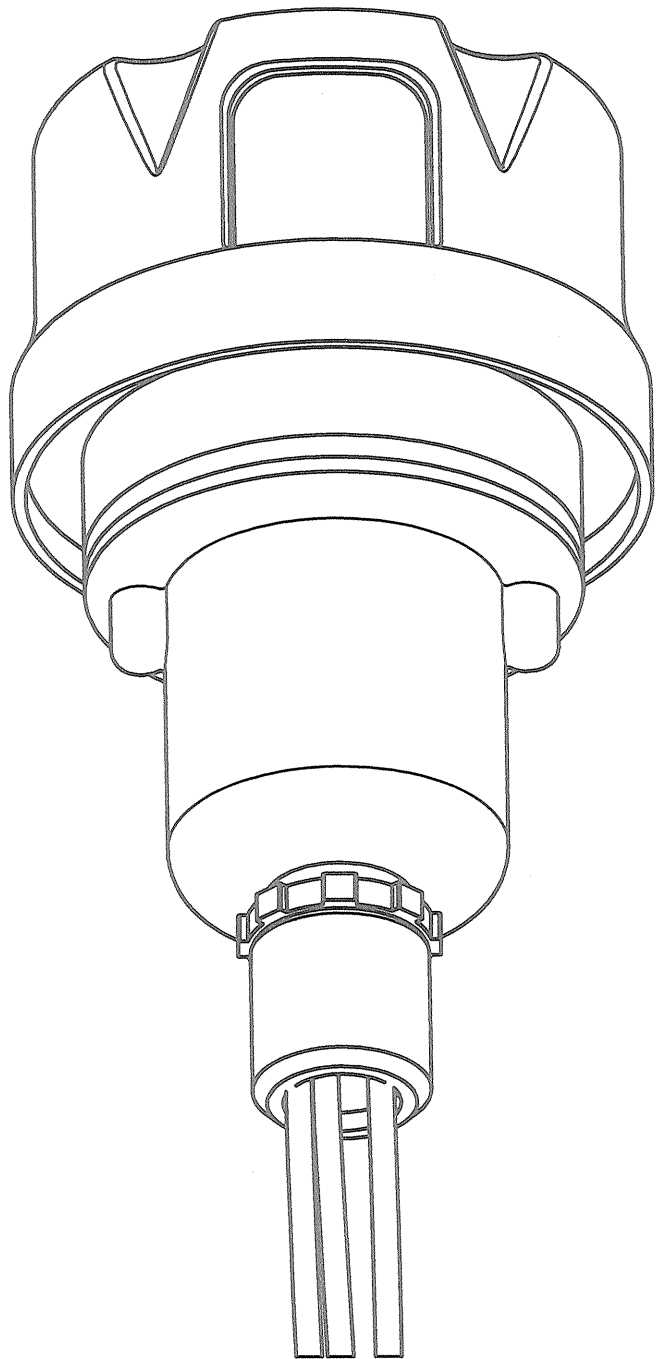

ASSEMBLY

NOTES:

- ITEM #7 CAN BE USED TO REDUCE 3/4" CONDUIT TO 1/2" CONDUIT AT THE HOUSING OR AT THE CONTROLLER ITSELF.
- IF ADDITIONAL WIRE IS REQUIRED OVER THE FACTORY 20', USE THE FOLLOWING CHART.  
 21' TO 300' - 16 AWG TFFN  
 301' TO 500' - 14 AWG TFFN

PHOTOCELL HOUSING DETAIL

PROD. DEPT  
 SERV. DEPT  
 ENGINEER  
**TWR Lighting, Inc. HARK**  
*Enlightened Technology®*

DRAWN BY	vhernandez	SHEET SIZE	B	SHEET QTY.	1 OF 1
DATE	10/18/1995	SCALE	1/1	DWG. NO.	100239i

DATE	REV	AUTHOR	DESCRIPTION
02/03/2015	H	JZAMORANO	UPDATED NOTES

4

3

2

1

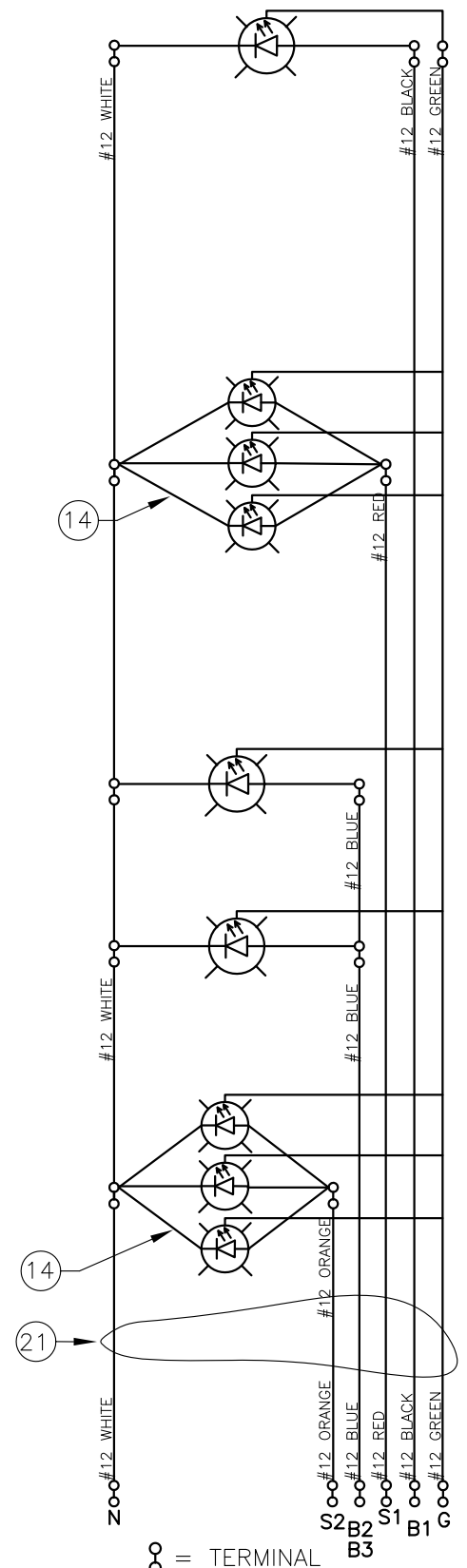
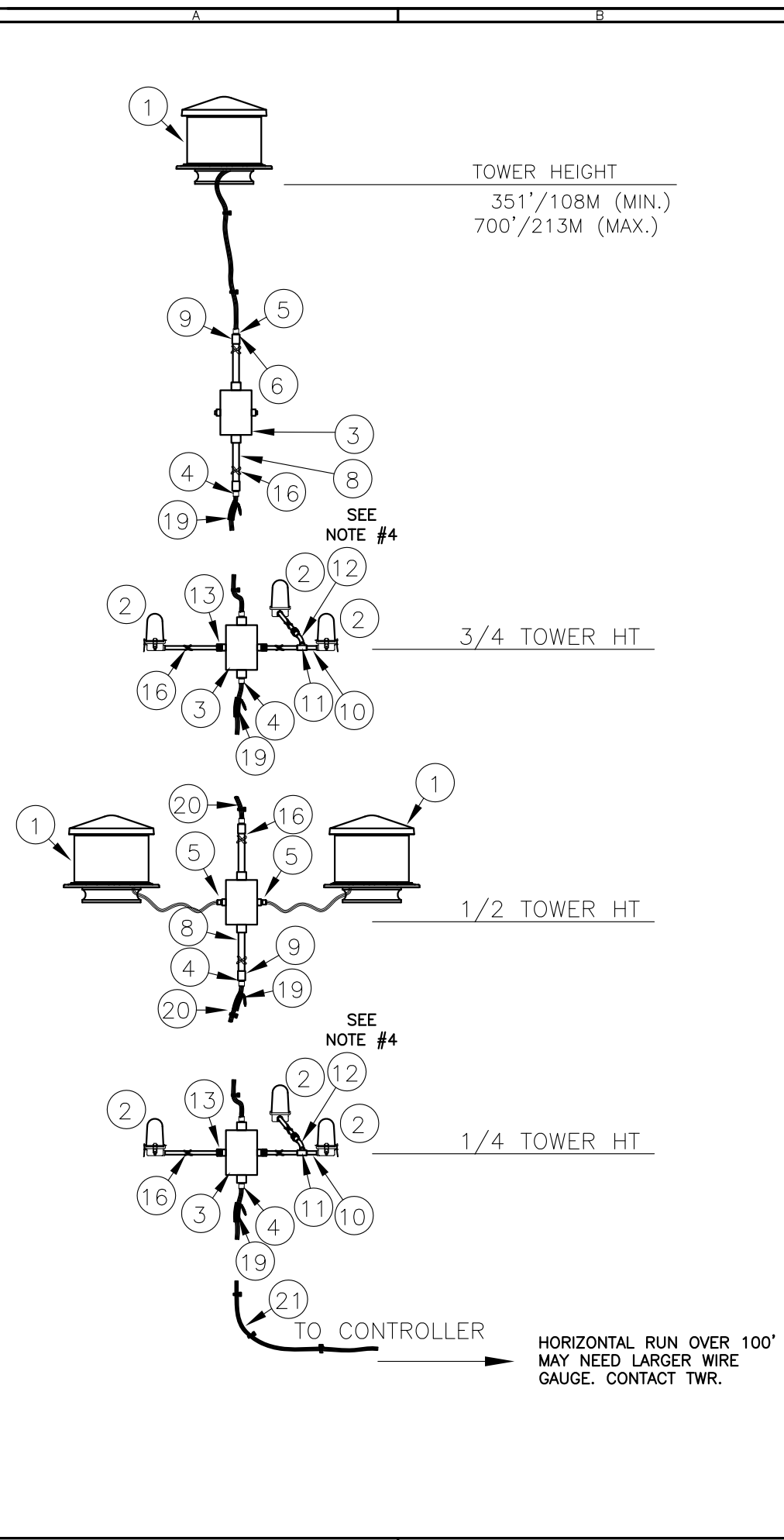

**MILLS CONTROLLER WIRING**  
MILLS = MEDIUM INTENSITY  
LED LIGHTING SYSTEM

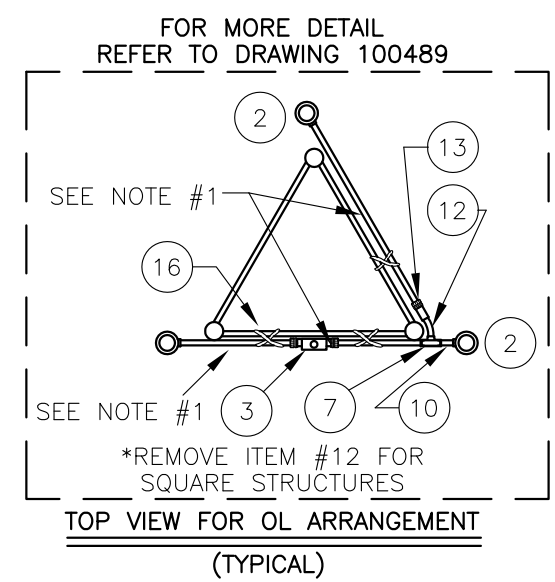

11/18/2014	(B)	UPDATED LEDS
DATE:	LTR.	REVISION

**BILL OF MATERIALS**

ITEM NO.	QTY.	TWR PART NO.	DESCRIPTION
1	3	LEDBEACON	120 VAC L-864 LED BEACON
2	6	OL1-LED	LED SIDELIGHT 3/4"
3	4	JB8C	1" JUNCTION BOX CAST
4	8	CGB396SA	1" CORD CONNECTOR 0.625 - .750
5	3	CGB295SA	3/4" CORD CONNECTOR 0.50 - 0.625
6	1	RE32	1" TO 3/4" REDUCER
7	6	A314	3/4" CONDUIT LOCKNUTS
8	4	N1T18	1" x 18" NIPPLE
9	4	CPLG1	1" GALVANIZED COUPLING
10	2	N34T3	3/4" x 3" NIPPLE
11	2	T27CG	3/4" CONDULET W/COVER & GASKET
12	2	EL3430	3/4" 30° ELBOW
13	6	HC402	3/4" NO THREAD CONNECTOR
14	6	SLPIGTAIL25G	25' SIDELIGHT PIGTAIL WITH GROUND
* 15	1	PIPDOP	4 oz. PIPE DOPE
16	1	SS10012	STAINLESS STEEL WRAPLOCK
17	60'	CONDUIT34	3/4" CONDUIT (FOR OL1 MOUNTING)
* 18	1	AA2/3_LED	AA2/3_LED RED LED LIGHT CONTROLLER
19	4	CABLGRIP6	SINGLE EYE LACE MESH .74-.99
20	-	STCABLTI	STROBE CABLE TIES (TWR HEIGHT +5)
21	-	CSO12/6	S.O. CORD, #12-6 WIRES (TWR HT.+BRIDGE+60'/18M)

\* = ITEMS NOT SHOWN  
~ = ITEMS QUANTITY CALCULATED ACCORDING TO STRUCTURE HEIGHT.

NOTES:  
1) ITEM #17 CUT TO LENGTH FOR PROPER EXTENSION OF OL1 (6"-12") FROM STRUCTURE. ATTACH ITEM #13 TO UNTHREADED CONDUIT TO COMPLETE ASSEMBLY.  
2) MOUNT BEACON HINGE SO LENS WILL OPEN UNOBSTRUCTED BY STRUCTURE.  
3) THIS DRAWING IS PROVIDED AS A GENERAL REFERENCE. TWR LIGHTING, INC. DOCUMENTATION SUPERSEDES THIS DRAWING & SHOULD BE REVIEWED PRIOR TO INSTALLATION OF THIS SYSTEM.  
4) USE COUPLING THAT IS PROVIDED WITH ITEM #17 TO ATTACH ITEM #12 TO ITEM #13.

**LK1A2/3LED TOWER LIGHTING KIT**  
(TOWERS 351'/108M TO 700'/213M)

PROD DEPT	<b>TWR Lighting, Inc.</b> <i>Enlightened Technology</i>	<b>WARK</b>
SERV DEPT		
ENGINEER		
DRAWN BY E.A.SALAZAR	SHEET SIZE B	SHEET QTY. 1 OF 1
DATE 10/26/04	SCALE N.T.S.	DWG. NO. 801-01

The use of non-OEM parts or modifications to original equipment design will void the manufacturer warranty and could invalidate the assurance of complying with FAA requirements as published in Advisory Circular 150/5345-43.  
NOTICE: The drawings and photographic images contained herein are the sole property of TWR Lighting, Inc. All information contained herein that is not generally known shall be considered confidential except to the extent the information has been previously established. The drawings and photographic images contained herein may not be reproduced, copied or used as the basis for manufacture or sale or promotion or any other purpose without the expressed written permission of TWR Lighting, Inc.

**BILL OF MATERIALS**

ITEM NO.	QTY.	TWR PART NO.	DESCRIPTION
1	3	LEDBEACON	LED BEACON
2	6	OL1LED	LED SIDELIGHT 3/4"
3	3	CGB295SA	3/4" CORD CONNECTOR 0.50 - 0.625
4	4	JBO	3/4" STRAIN RELIEF
5	5	JB5/7	3/4" JUNCTION BOX
6	3	T27CG	3/4" CONDULET W/COVER AND GASKET
7	2	EL3430	3/4" 30° ELBOW
8	2	EL3490	3/4" 90° ELBOW
9	24	A314	3/4" CONDUIT LOCKNUTS
* 10	2	PIPDOP	4 oz. PIPE DOPE
11	2	N34T3	3/4" x 3" NIPPLE
12	4	UNY205	3/4" UNION
13	4	5012902	3/4" BREATHER
14	4	N34T18	3/4" x 18" NIPPLE
15	4	EXPJNT34	3/4" EXPANSION JOINT
16	6	HC402	3/4" NO THREAD CONNECTOR
17	6	SLPIGTAIL25G	25' SIDELIGHT PIGTAIL WITH GROUND
18	2	SS10012	STAINLESS STEEL WRAPLOCK 100'
19	60'	CONDUIT34	3/4" CONDUIT
* 20	1	AA2/3	AA2/3 LED CONTROLLER

ITEM NUMBERS #21-#26 ARE NOT INCLUDED IN THE KIT BUT ARE AVAILABLE UPON REQUEST, AND REQUIRED FOR INSTALLATION.

21	-	CONDUIT34	3/4" CONDUIT (TOWER HT. + 40'/12M)
22	-	12THHNWHT	#12 THHN WHT. WIRE (TOWER HT.+60'/19M)
23	-	12THHNBK	#12 THHN BLK. WIRE (TOWER HT.+60'/19M)
24	-	12THHNRED	#12 THHN RED WIRE (3/4 TWR HT.+60'/19M)
25	-	12THHNBLUE	#12 THHN BLUE WIRE (1/2 TOWER HT.+60'/19M)
26	-	12THHNYLW	#12 THHN YLW. WIRE (1/4 TWR HT.+60'/19M)

\* = ITEMS NOT SHOWN

**NOTES:**

- ITEM #19 CUT TO LENGTH FOR PROPER EXTENSION OF OL1 (6"-12") FROM STRUCTURE. ATTACH ITEM #16 TO UNTHREADED CONDUIT TO COMPLETE ASSEMBLY.
- MOUNT BEACON HINGE SO LENS WILL OPEN UNOBSTRUCTED BY STRUCTURE.
- ON AM TOWER APPLICATIONS, KEEP GROUND LUG FROM BEING CONNECTED TO EARTH GROUND. GROUND TO THE TOWER ONLY.
- THIS DRAWING IS PROVIDED AS A GENERAL REFERENCE. TWR LIGHTING, INC. DOCUMENTATION SUPERSEDES THIS DRAWING & SHOULD BE REVIEWED PRIOR TO INSTALLATION OF THIS SYSTEM.
- USE COUPLING THAT IS PROVIDED WITH ITEM #19.
- CONDUIT SIZE BASED ON USING TYPE THHN WIRE.
- USE RIGID GALVANIZED STEEL CONDUIT.
- BREATHERS ALLOW FOR CIRCULATION OF AIR TO PREVENT CONDENSATION.

**LK2A2/3LED TOWER LIGHTING KIT**  
(TOWERS 351'/108M TO 700'/213M)

PROD DEPT	<b>TWR Lighting, Inc.</b> <i>Enlightened Technology®</i>	SHEET SIZE	SHEET QTY.
SERV DEPT		B	1 OF 1
ENGINEER			
DRAWN BY	E.A.SALAZAR	SCALE	N.T.S.
DATE	06/16/04	DWG. NO.	801-02

The use of non-OEM parts or modifications to original equipment design will void the manufacturer warranty and could invalidate the assurance of complying with FAA requirements as published in Advisory Circular 150/5345-43.  
NOTICE: The drawings and photographic images contained herein are the sole property of TWR Lighting, Inc. All information contained herein that is not generally known shall be considered confidential except to the extent the information has been previously established. The drawings and photographic images contained herein may not be reproduced, copied or used as the basis for manufacture or sale or promotion or any other purpose without the expressed written permission of TWR Lighting, Inc.

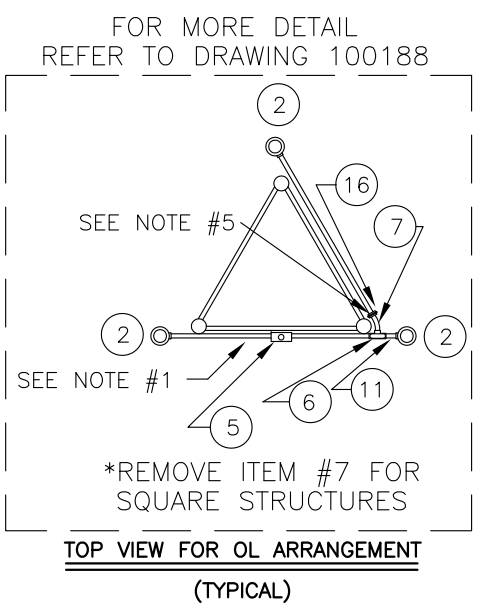
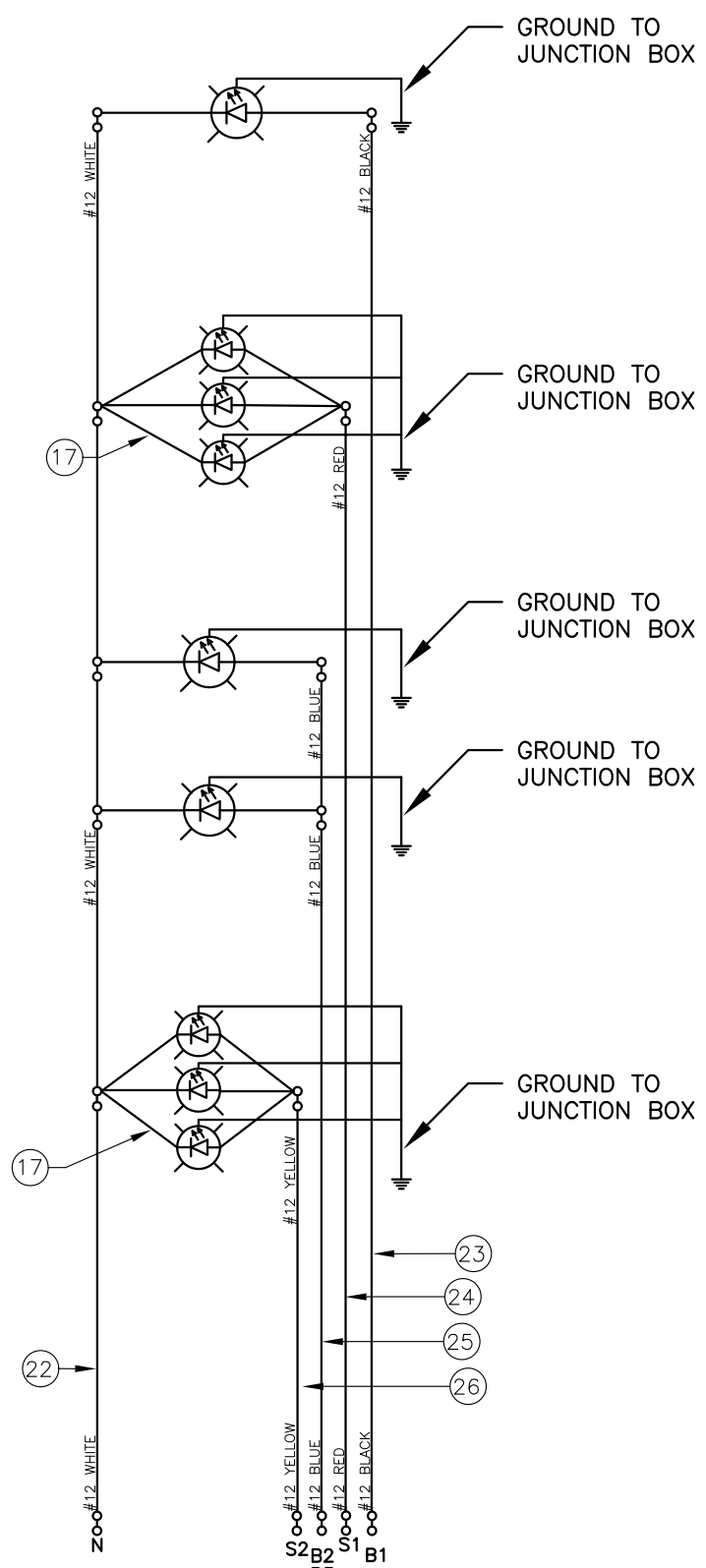
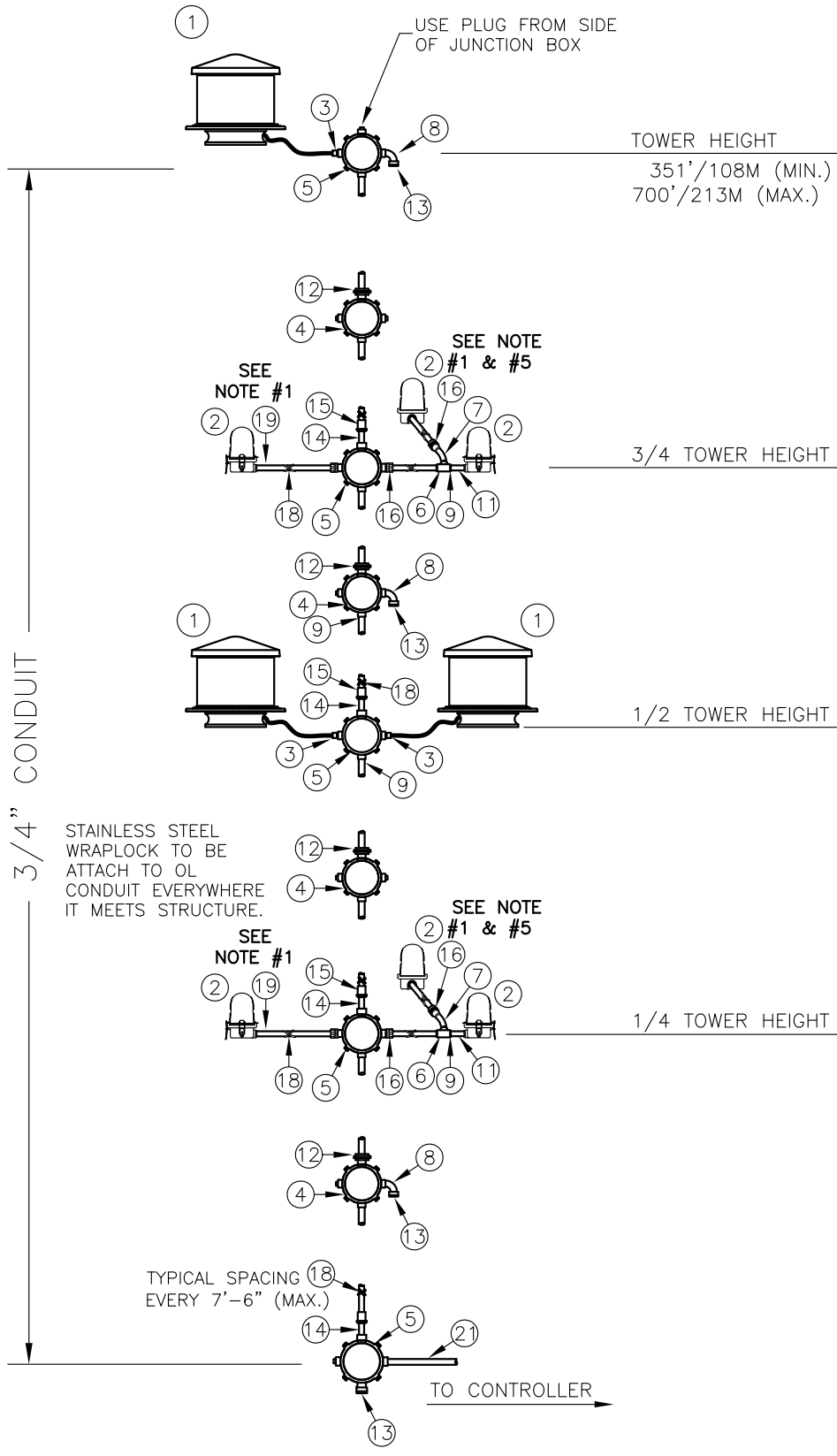

11/18/2014		UPDATED LEDS
DATE:	LTR.	REVISION



# AC UNITS CURRENT MEASUREMENT RM22JA31MRSP01

## 120VAC PRODUCT SPECIFIC SETTINGS

QTY.	PART NO.	INPUT	#1	#2	#3	#4	#5
1	OL1_LED2	E2	*<1	30	20	30	OFF
2	OL1_LED2	E2	*<1	50	20	30	OFF
3	OL1_LED2	E3	*<1	<b>15</b>	20	30	OFF
4	OL1_LED2	E3	*<1	25	20	30	OFF
6	OL1_LED2	E3	*<1	35	20	30	OFF
8	OL1_LED2	E3	*<1	45	15	30	OFF
10	OL1_LED2	E3	*<1	60	10	30	OFF
1	LEDBEAON2	E3	*<1	<b>20</b>	20	30	OFF
1	LEDBEAON2A	E3	*<1	<b>15</b>	20	30	OFF
1	LEDBEAON2(T)	E3	*<1	<b>25</b>	20	30	OFF
1	STLDBEAON2	E3	*<1	<b>20</b>	20	30	OFF
1	STLDBEAON2A	E3	*<1	<b>15</b>	20	30	OFF
2	STLDBEAON2A	E3	*<1	<b>25</b>	20	30	OFF
2	STLDBEAON2A	E3	*<1	<b>25</b>	20	30	OFF

\*NO MEMORY

### FUNCTIONS

- 1) Configuration: Selection of operation mode (<1 / >1 / >1<) with or without memory.
- 2) Adjustment of current threshold as % of setting range.
- 3) Hysteresis adjustment from 5% to 50%.
- 4) Time Delay adjustment from 0.1 to 30sec.
- 5) Diagnostic button.
- 6) Yellow indicator light (**See conditions below**)
- 7) Dial Pointer (Green) LED
  - Steady green LED indicates that supply to the RM22 is present
  - Flashing green LED indicates a setting has been changed that requires a power cycle.

### YELLOW LED CONDITIONS

**NOTE:** ( ) ASTERISK INDICATES LED CONDITIONS OPERATE OPPOSITE FROM RM22JA31MR MODULE

\*

- ➔ Steady Burn Fixtures
  - Yellow light \*off : Normal condition (no alarm)
  - Yellow light flashing : Undercurrent condition detected and time delay initiated
  - Yellow light \*on : Alarm condition
- ➔ Flashing Fixtures
  - Yellow light flashing inconsistent : Normal condition (no alarm)
  - Yellow light flashing consistent : Under current condition detected and time delay initiated

**NOTE :** To help troubleshoot or to set the sense current, turn the time delay to 0sec. Adjusting the current setting should only be done if it is known that all the lights are functioning. For Steady Burn adjust the current until the yellow LED comes \*off, and the relay is not dropping in and out. For Flashing Fixtures adjust the current setting until the yellow light starts to flash. This is the normal condition setting. Return the time delay back to 30sec.

- Yellow light \*on : Alarm condition

\*\* Due to current draw tolerances slight adjustments to setting #2 may be needed for proper alarming.

CONTROL VOLTAGE INPUT

4-40mA INPUT

OUTPUT TO LOAD

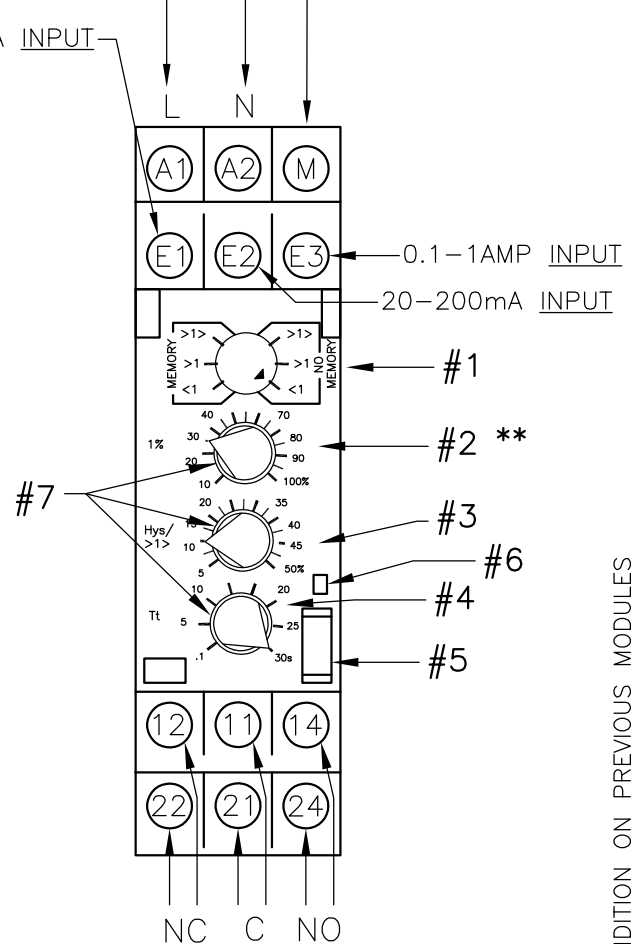

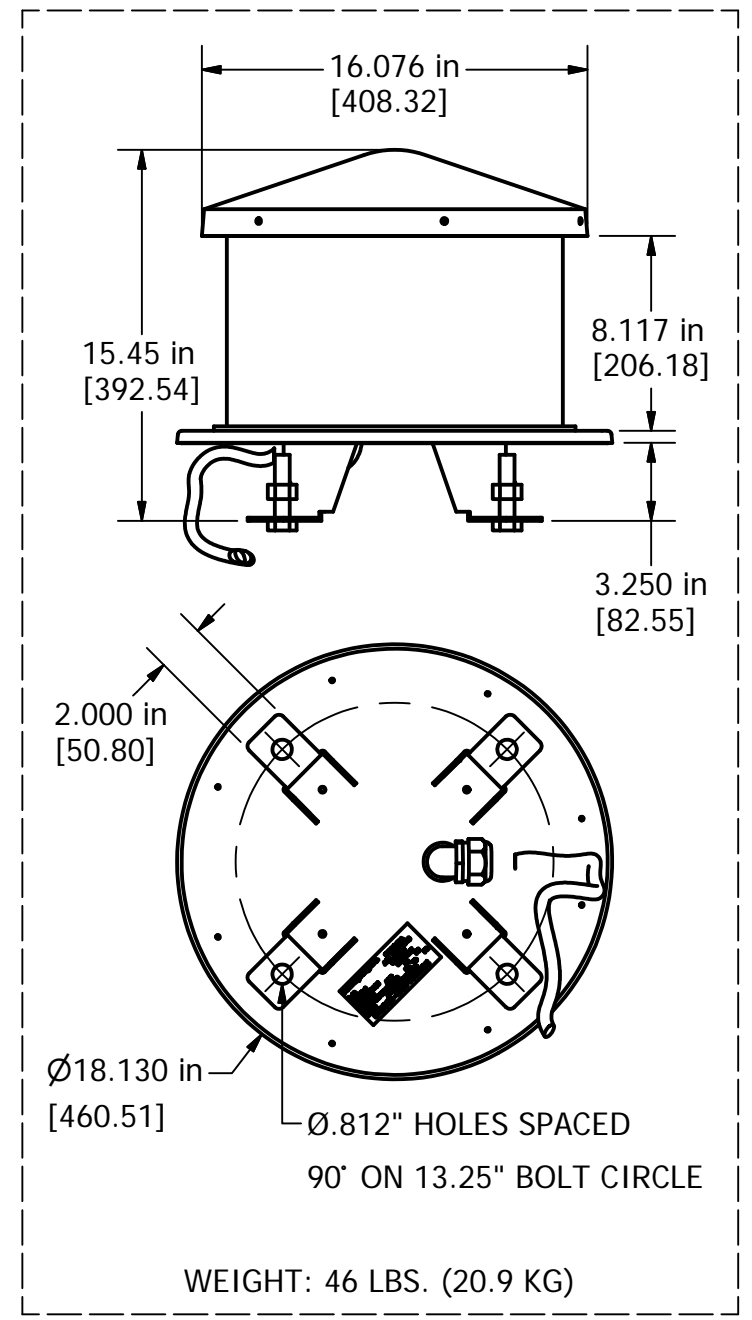
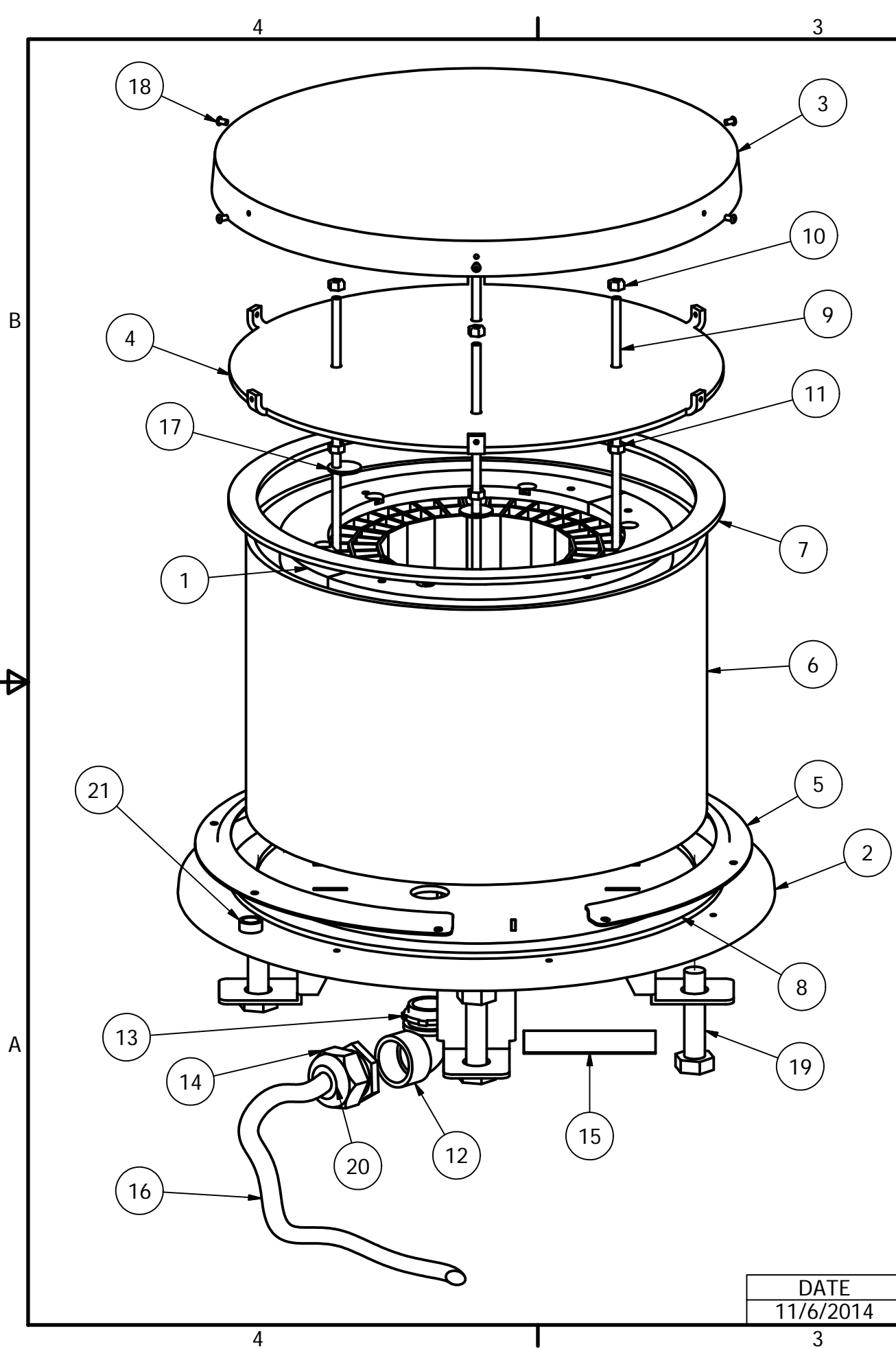

Parts List				
ITEM	QTY	PART NUMBER	DESCRIPTION	
1	1	LEDLITEENG2	ORGA L-864 LED LIGHT ENGINE 120/240VAC	
2	1	100672	LED BEACON BASE PLATE	
3	1	100344	CAP DUAL BEACON	
4	1	100673	LED BEACON LID PLATE	
5	2	100337	LENS RETAINER RING	
6	1	STLDBCTUBE2	CLEAR ACRYLIC TUBE	
7	1	STBEAGSK4	GASKET NEOPRENE 13 1/8 X 15 OD X	
8	1	STBEAGSKT	GASKET NEOPRENE 13 1/4 X 15	
9	4	100727	14-20 X 9.875" DE 304 S.S. ORG	
10	4	1420SSNUTN	1/4-20 NUT W/NYLON INSERT 304	
11	4	1420NUT	1/4-20 NUT 304 S/S	
12	1	EL190S	1" 90 DEGREE SHORT ELBOW GALV.	
13	1	A315	1" CONDUIT LOCKNUT GALV.	
14	1	CC-NPT34-G	3/4" NPT CORD CONNECTOR .500"	
15	1	STCONLAB2	100223 PRODUCT LABEL	
16	21'	CSO14-3	S.O. CORD 14AWG/3 CONDUCTOR	
17	2	100606M	LED LIGHT ENGINE TIE DOWN WASH	
18	6	18PRSS-2	1/8 X .400 SS POP RIVET #44	
19	4	58X112	5/8 X 1-1/2 HEX BOLT	
20	1	RE32	1" TO 3/4" REDUCER, GALV.	
21	1	2-10000	CIRCULAR SPIRIT LEVEL	
*	22	8	1032X38PHW	10-32X3/8 PHILLS HD CAPTIVE SCREW

\* = ITEMS NOT SHOWN

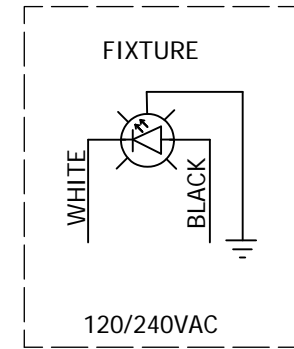

\* GROUND WIRE MUST BE CONNECTED TO PROPERLY PROTECT POWER SUPPLY. FAILURE TO GROUND WILL VOID ALL WARRANTIES.

DATE	AUTHOR	REV	DESCRIPTION
11/6/2014	JZamorano	C	UPDATED BOM

DRAWN VHernandez	9/4/2007	<b>TWR Lighting, Inc. PARK</b> <i>Enlightened Technology®</i>	
CHECKED			
QA		TITLE	
MFG		LED BEACON2 ASSEMBLY	
APPROVED		SIZE B	DWG NO 100761
		SCALE 1/4	REV C
		SHEET 1 OF 1	

4

3

2

1

Parts List

ITEM	QTY	PART NUMBER	DESCRIPTION
1	1	OL1VLED2	L810 OBSTRUCTION LIGHT
* 1.1	1	100588_RE	OL 6LED BASE PLATE
* 1.2	1	100591	OL 6LED STAR DISK
* 1.3	1	100680	OL1/2 SERIAL # LABEL
* 1.4	1	A10290	5/32" ID RUBBER GROMMET
* 1.5	6	STD05008	LED EMITTER
* 1.6	1	OLG	OL GASKET
* 1.7	1	AP100846	SIDELIGHT LENS CLEAR ACYRLIC
* 1.8	1	106V	LENS HOLDER RING
* 1.9	6	STE01-047	LED VERTICAL PCB
* 1.10	16	18PRSS	1/8 X .45 SS POP RIVET
* 1.11	1	PS90-260/24	POWER SUPPLY
* 1.12	1	20RED	#20AWG RED BELDON WIRE
* 1.13	2	WIRENUTBLU	BLUE WIRE NUT
2	2	HC255SS	SIDELIGHT LATCH
3	1	7X7SS	1/16 HOL 7X7 S.S. WIRE
4	2	12V245	OL LENS CLIP
5	1	105V	SINGLE SIDELIGHT BODY
6	2	832X14PH	8-32 X 1/4 PH SS SLOT SCREW
7	2	A1A	STAKON CRIMP
8	1	A314	3/4" CONDUIT LOCKNUT GALV.

\* = ITEMS NOT SHOWN

B

B

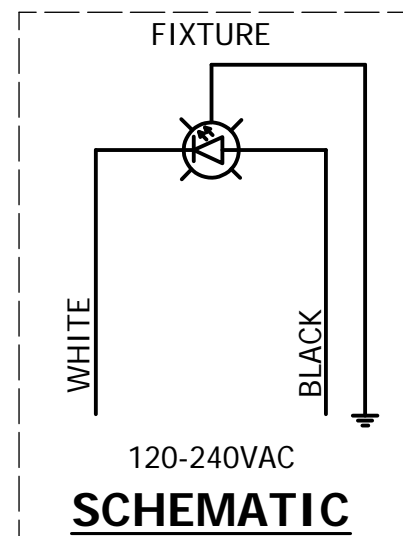
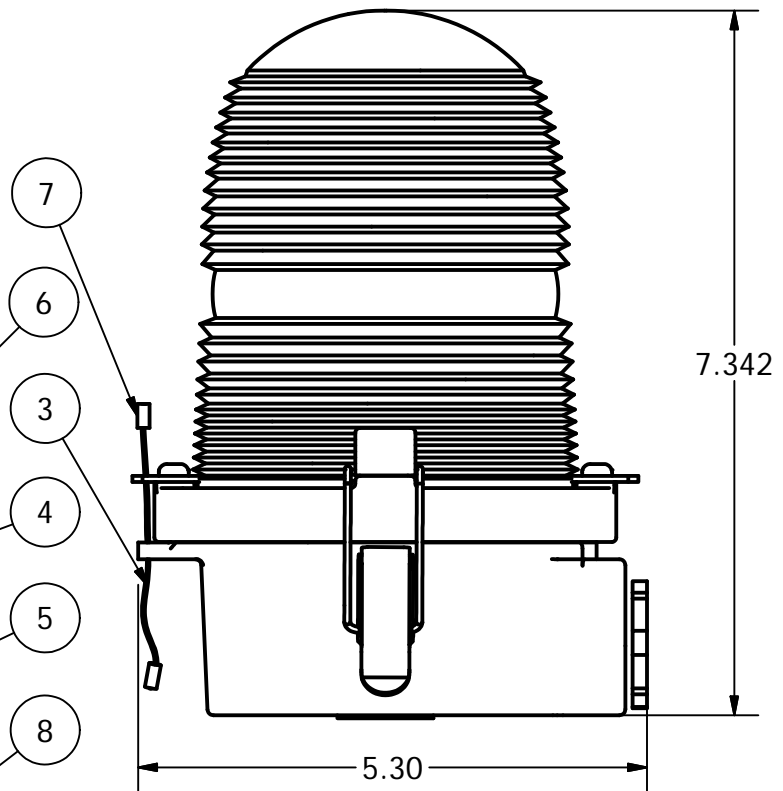
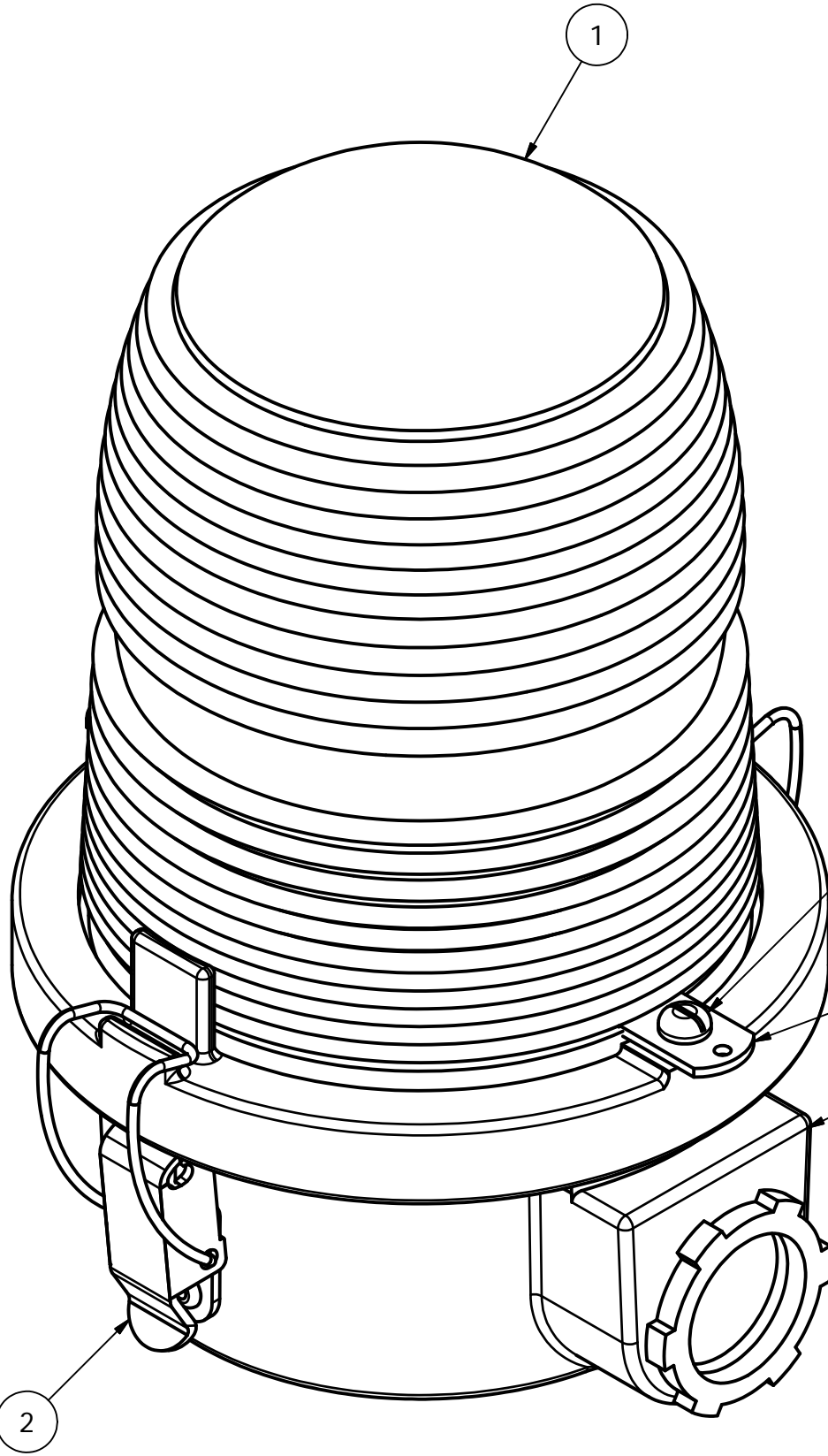

\* GROUND WIRE MUST BE CONNECTED TO PROPERLY PROTECT POWER SUPPLY. FAILURE TO GROUND WILL VOID ALL WARRANTIES.

A

A

DRAWN	gsebek	8/18/2004
CHECKED		
QA		
MFG		
APPROVED		

**TWR Lighting, Inc.** **PARK**  
Enlightened Technology®

TITLE		
OL1VLED2 120-240VAC FAA-OL16LED (L810 OBSTRUCTION LIGHT)		
SIZE	DWG NO	REV
B	100656i	E
SCALE	SHEET 1 OF 1	

DATE	REV	AUTHOR	DESCRIPTION
11/07/14	E	JZAMORANO	REM. WIRE CONNECT

4

3

2

1

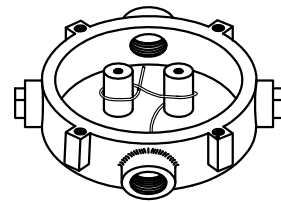
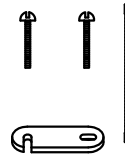
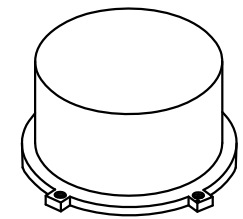
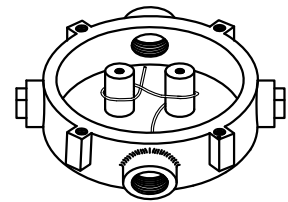
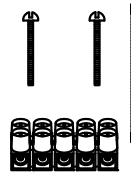
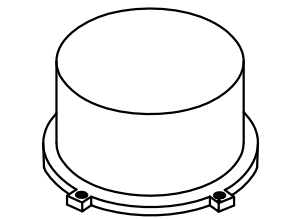

JB-5 AND JB-0  
3/4" JUNCTION BOX

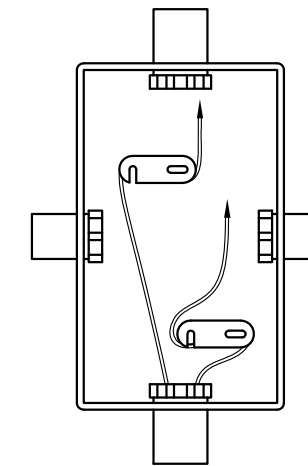
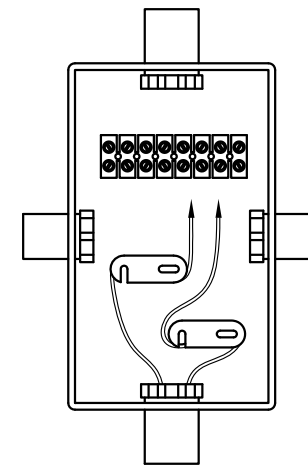

JB-8 AND JB-8SR  
1" JUNCTION BOX

**NOTES:**

- 1) DRAWING ILLUSTRATES METHOD OF STRAIN RELIEVING WIRE. USE THIS METHOD ON ALL JUNCTION BOXES.
- 2) THE NATIONAL ELECTRICAL CODE-ARTICLE 300-19-B3 REQUIRES CONDUCTORS IN A VERTICAL CONDUIT BE SUPPORTED TO RELIEVE STRAIN ON TERMINAL BLOCK CONNECTIONS.
- 3) SKETCH ILLUSTRATES METHOD OF STRAIN RELIEVING A SINGLE CONDUCTOR. SEVERAL CONDUCTORS MAY BE GROUPED TOGETHER.
- 4) CONDUCTORS MAY BE MIXED BUT SHOULD NOT TAKE UP MORE THAN 40% OF CONDUIT'S INSIDE AREA.

USING THIS JUNCTION BOX METHOD SPACING IS 100 FEET MAXIMUM.

AWG WIRE SIZE	MAX. NUMBER WIRES IN 3/4" CONDUIT	MAX. NUMBER WIRES IN 1" CONDUIT	WIRE AREA SQ. INCHES	WEIGHT PER 100 FEET
12 THHN	16	26	0.0117	2.50
10 THHN	10	17	0.0184	4.10
8 THHN	6	9	0.0373	6.70
6 THHN	4	7	0.0519	10.30
4 THHN	2	4	0.0845	16.20

<u>JUNCTION AND STRAIN RELIEF BOXES</u>					
PROD DEPT	<b>TWR Lighting, Inc.</b> <i>Enlightened Technology®</i>				
SERV DEPT					
ENGINEER					
DRAWN BY	G.D. SEBEK	SHEET SIZE	B	SHEET QTY.	1 OF 1
DATE	07/26/93	SCALE	N.T.S.	DWG. NO.	100089

9/29/00	(A)	UPDATED NOTES
DATE:	LTR.	REVISION

The use of non-OEM parts or modifications to original equipment design will void the manufacturer warranty and could invalidate the assurance of complying with FAA requirements as published in Advisory Circular 150/5345-43.  
NOTICE: The drawings and photographic images contained herein are the sole property of TWR Lighting, Inc. All information contained herein that is not generally known shall be considered confidential except to the extent the information has been previously established. The drawings and photographic images contained herein may not be reproduced, copied or used as the basis for manufacture or sale or promotion or any other purpose without the expressed written permission of TWR Lighting, Inc.

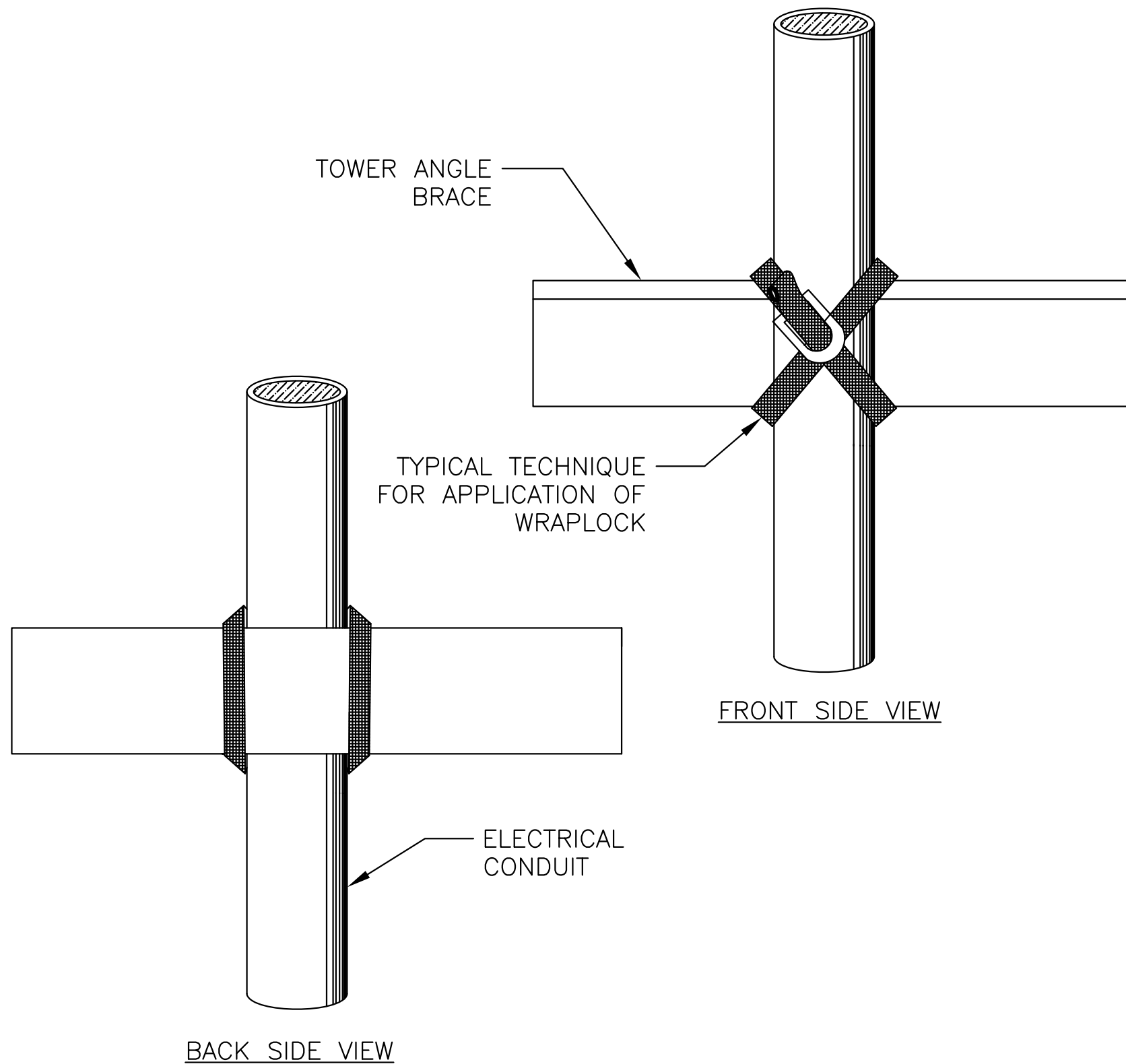

## DIRECTIONS FOR USING WrapLock

CUT OFF BAND TO PROPER LENGTH.  
(SEE TABLE ON COVER OF BOX)

- 1.— PASS ONE END THROUGH YOKE AND BEND BACK ABOUT 1 1/2" AND FLATTEN DOWN.
- 2.— PASS BAND AROUND WORK AND THROUGH YOKE.
- 3.— REPEAT AND PASS END THROUGH A SECOND TIME, DRAW UP FREE END SNUGLY WITH PLIERS.



- 4.— INSERT FREE END IN SLOT OF RATCHET.
- 5.— TURN DOWN UNTIL CLAMP IS TIGHT.
- 6.— BACK OFF SLIGHTLY TO REMOVE RATCHET. CLAMP IS NOW SECURELY LOCKED.

**TO REMOVE WrapLock**  
UNCOIL END WITH RATCHET. PRESS DOWN AT POINT WHERE BAND METAL HAS BEEN FORCED THROUGH CURVED PART OF YOKE.

### WRAPLOCK FASTENING DETAIL

ENGINEER	<b>TWR Lighting, Inc.</b> <i>Enlightened Technology®</i>		
APPROVED			
APPROVED			
APPROVED	DRAWN BY M. PETERMAN	SHEET SIZE B	SHEET QTY. 1 OF 1
APPROVED	DATE 05/01/2014	SCALE N.T.S.	DWG. NO. 100984

The use of non-OEM parts or modifications to original equipment design will void the manufacturer warranty and could invalidate the assurance of complying with FAA requirements as published in Advisory Circular 150/5345-43.  
NOTICE: The drawings and photographic images contained herein are the sole property of TWR Lighting, Inc. All information contained herein that is not generally known shall be considered confidential except to the extent the information has been previously established. The drawings and photographic images contained herein may not be reproduced, copied or used as the basis for manufacture or sale or promotion or any other purpose without the expressed written permission of TWR Lighting, Inc.