

TWR Lighting, Inc. HARK[®]

Enlightened Technology[®]

10810 W. LITTLE YORK RD., #130 HOUSTON, TX 77041-4051
VOICE: (713) 973-6905 FAX: (713) 973-9352
web: www.twrlighting.com

IMPORTANT!!!

PLEASE TAKE THE TIME TO FILL OUT THIS FORM COMPLETELY. FILE IT IN A SAFE PLACE. IN THE EVENT YOU EXPERIENCE PROBLEMS WITH OR HAVE QUESTIONS CONCERNING YOUR CONTROLLER, THE FOLLOWING INFORMATION IS NECESSARY TO OBTAIN PROPER SERVICE AND PARTS.

MODEL # AA2-TSS

SERIAL # _____

PURCHASE DATE _____

PURCHASED FROM _____

TWR Lighting, Inc. **HARK**

Enlightened Technology

AA2-TSS CONTROLLER

TABLE OF CONTENTS

1.0	GENERAL INFORMATION.....	1
2.0	INSTALLATION INSTRUCTIONS	2
2.1	MOUNTING THE CONTROL CABINET	2
2.2	EXTERNAL PHOTOCELL WIRING	3
2.3	POWER WIRING	3
2.4	RED BEACON AND SIDELIGHT WIRING.....	3
3.0	THEORY OF OPERATION	5
3.1	POWER SUPPLY	5
3.2	SIDELIGHTS	5
3.3	BEACONS	5
4.0	TROUBLESHOOTING GUIDE.....	6
4.1	SYMPTOM – BEACON NOT FLASHING.....	6
4.2	SYMPTOM – SIDELIGHT OUT	6
4.3	SYMPTOM – CONTROLLER ALWAYS “ON”	6
5.0	MAINTENANCE GUIDE.....	7
5.1	RED OBSTRUCTION LIGHTING	7
5.2	L-864 LAMP REPLACEMENT	7
5.3	L-810 LAMP REPLACEMENT	8
5.4	L-864 CONTROLLER.....	8
5.5	PHOTOCELL.....	8
6.0	MAJOR COMPONENTS PARTS LIST	9
7.0	SUGGESTED SPARE PARTS LIST	10

WARRANTY & RETURN POLICY

RETURN MERCHANDISE AUTHORIZATION (RMA) FORM

TWR Lighting, Inc. HARK[®]

Enlightened Technology[®]

AA2-TSS CONTROLLER

APPENDIX

CHASSIS COMPONENT LAYOUT	203-R (REV D)
SCHEMATIC LAYOUT	203-S (REV D)
TROUBLESHOOTING FLOW CHART	203-F (REV A)
TOWER LIGHTING KIT 351' TO 700'	361-12
L-810 OL-1 SINGLE OBSTRUCTION LIGHT DETAIL.....	279-OL (REV C)
L-810 OL-1 SINGLE OBSTRUCTION WIRING DETAIL	274-S (REV A)
L-864 FB 300 MM BEACON DETAIL.....	275-B (REV E)
L-864 FB 300 MM BEACON WIRING DETAIL	273-B
JUNCTION BOX DETAIL	100089 (REV A)
WRAPLOCK FASTENING DETAIL.....	100984

TWR Lighting, Inc. **MARK**[®]

Enlightened Technology[®]

AA2-TSS CONTROLLER

1.0 GENERAL INFORMATION

The TWR Lighting[®], Inc. (TWR[®]) Model AA2-TSS Controller is for A1 lighting of towers 351' to 700' AGL (above ground level) in accordance with the Federal Aviation Advisory Circular 70/7460-1K. One (1) beacon should be placed at the top of the structure, and the other beacon put at mid point. Three (3) obstruction lights should be placed at the $\frac{3}{4}$ and $\frac{1}{4}$ levels with respect to overall tower height.

The flash rate of the beacons is 30 per minute. The sidelights burn steady.

A by-pass switch (SW1) allows the controller to be turned on during daylight hours without covering the photocell. This is particularly helpful since the controller can be mounted indoors while the photocell is outdoors. SW1 can be operated by turning the switch to "ON."

The beacon requires two (2) 620 watt, or two (2) 700 watt, 120V bulbs. TWR[®] recommends that you use only these bulbs. Each sidelight requires one (1) 116 watt, 120V bulb (620PS40P, 700PS40P, and 116A21TS).

The photocell is the three (3) blades, twist to lock, type.

Power supplied to the controller shall be 120V AC 50/60 Hz.

The controller housing is rated at NEMA 4X. It is suitable for indoor or outdoor mounting.

AA2-TSS CONTROLLER

2.0 INSTALLATION INSTRUCTIONS

2.1 MOUNTING THE CONTROL CABINET

(Refer to Drawing 203-R)

The power supply control cabinet can be located at the base of the structure or in an equipment building. Mounting footprints are shown on drawing 203-R. Power wiring to the control cabinet should be in accordance with local methods and National Electrical Codes (NEC).

2.1.1 If the control cabinet is mounted inside an equipment building, the photocell should be mounted vertically on ½” conduit outside the building above the eaves facing north. Wiring from the photocell socket to the control cabinet should consist of one (1) each, red, black, and white wires. The white wire is connected to the socket terminal marked “W,” the black wire is connected to the socket terminal marked “B,” and the red wire is connected to the socket terminal marked “R.” The photocell should be positioned so that it does not “see” ambient light, which would prevent it from switching to the nightmode.

2.1.2 If the control cabinet is mounted outside an equipment building, the photocell should be mounted vertically on ½” conduit so the photocell is above the control cabinet. Care must be taken to assure that the photocell does not “see” any ambient light that would prevent it from switching into the nightmode. The photocell wiring is the same as in 2.1.1.

2.1.3 The wiring from the photocell, the service breaker, the red incandescent beacons, and the sidelights should enter the control cabinet through the watertight connectors in the bottom of the cabinet. Inside the cabinet, the connections will be made on the terminal strips and circuit breakers located at the bottom of the chassis. These connections are made as follows:

AA2-TSS CONTROLLER

2.2 EXTERNAL PHOTOCELL WIRING

(Refer to Drawing 203-R)

2.2.1 Connect the **BLACK** wire from the photocell to terminal block TB2 marked "L."

2.2.2 Connect the **RED** wire from the photocell to terminal block TB2 marked "SSR."

2.2.3 Connect the **WHITE** wire from the photocell to terminal block TB2 marked "N."

2.3 POWER WIRING

(Refer to Drawing 203-R)

2.3.1 Power wiring to the control cabinet should be in accordance with local methods and National Electrical Codes (NEC).

2.3.2 Circuit breaker needs to be rated at 30 amps.

2.3.3 Connect incoming 120V AC to terminal block TB1 marked "L."

2.3.4 Connect the neutral wire(s) to one (1) of the terminal blocks on TB1 marked "N."

2.3.5 Connect the AC ground to the aluminum mounting plate.

AA2-TSS CONTROLLER

2.4 RED BEACON AND SIDELIGHT WIRING

(Refer to Drawings 203-R, and 361-12)

- 2.4.1 Connect the **BLACK** wire from beacon # 1 to the circuit breaker marked "B1."
- 2.4.2 Connect the **BLUE** wire from beacon #2 to the circuit breaker marked "B2."
- 2.4.3 Connect the **RED** and **YELLOW** wire from the sidelight group to the circuit breaker marked "S."
- 2.4.3 Connect the neutral wire(s) to one (1) of the terminals on TB1 marked "N."

AA2-TSS CONTROLLER

3.0 THEORY OF OPERATION

3.1 POWER SUPPLY

120V AC enters the controller from the circuit breaker panel. Line sits at the PRD, waiting to be switched on. When the 6390-FAA photocell is activated, line energizes the coil of the PRD relay. This also can be accomplished by using the photocell by-pass switch (SW1).

3.2 SIDELIGHTS

Line (S) is sent to the circuit breaker marked "S," which powers the sidelight circuit.

3.3 BEACONS

Line (LD) is sent to Modules M1 and M2. M1 is the primary flasher and with M2 being the auxiliary flasher, M1 output is sent to Module M2 for control voltage as well as the circuit breaker marked "B1." The output of M2 will be sent to the circuit breaker marked "B2."

AA2-TSS CONTROLLER

4.0 TROUBLESHOOTING GUIDE

4.1 SYMPTOM – BEACON NOT FLASHING

Check for pulsing 120V AC at “B1” and “B2” circuit breakers. If the circuit breaker is tripped, there may have been a surge or a short in the tower wiring. Looking for a short between the circuit breakers and ground can check this. If okay, and 120V AC is not present, then check for voltage on the input of Module M1, and M2. If okay, the flasher module has probably failed and needs to be replaced. If everything appears to be correct but the beacon still does not work, check tower wiring and the lamps within the beacons.

4.2 SYMPTOM – SIDELIGHT OUT

Check for constant 120V AC at “S” circuit breaker. If tripped, check for a short in the tower wiring. If not, and voltage is present, check the tower wiring and the lamp within the sidelights.

4.3 SYMPTOM – CONTROLLER ALWAYS “ON”

If the tower lights stay on in the daytime, check to see that switch SW1 is off. If the switch is off, then remove the photocell out of the socket. If the lights go out, replace the photocell. If not, check for welded contacts on the PRD. Replace if necessary.

AA2-TSS CONTROLLER

5.0 MAINTENANCE GUIDE

5.1 RED OBSTRUCTION LIGHTING

The only required maintenance needed to be performed is replacement of the lamps in the L-864, and L-810 fixtures. Lamps should be replaced after being operated for not more than 75% of the rated life or immediately upon failure as per Federal Aviation Advisory Circular 70/7460-1K. By following these instructions, maximum safety and performance can be achieved.

TOOLS REQUIRED: NONE

5.2 L-864 LAMP REPLACEMENT

5.2.1 Loosen the one (1) wing nut on the latch pin so that it can recline.

5.2.2 Open the lens and tilt it back.

5.2.3 To remove each lamp, depress down while rotating the lamp counter-clockwise 90°.

5.2.4 Install the new lamps by depressing down while rotating the lamp clockwise 90°.

5.2.5 Close the lens and let the latch pin drop in the recessed slot.

5.2.6 Tighten the wing nut snug, then ¼ turn more.

AA2-TSS CONTROLLER

5.3 L-810 LAMP REPLACEMENT

- 5.3.1 Unclasp the two (2) latches and let the bails recline back.
- 5.3.2 Lift the lens up and over the lamp, letting the lens hang from the safety cable.
- 5.3.3 Unscrew the lamp counter-clockwise and remove.
- 5.3.4 Install the new lamp by screwing the lamp clockwise.
- 5.3.5 Reinstall the lens, making sure it is seated properly on the base.
- 5.3.6 Reclasp the two (2) latches.

5.4 L-864 CONTROLLER

No scheduled maintenance is required. Perform on an “as needed” basis only.

5.5 PHOTOCELL

The photocell is a sealed unit. No maintenance is needed or required other than replacement as necessary.

TWR Lighting, Inc. HARK®

Enlightened Technology®

AA2-TSS CONTROLLER

6.0 MAJOR COMPONENTS PARTS LIST

QTY	PART NUMBER	DESCRIPTION
1	6390-FAA (This replaces the 102FAA Photocell)	120 – 240V AC Photocell
1	PF-250 (This replaces the FS15530T)	Solid State Flasher (M1)
1	SF-250 (This replaces the FA1552 Module)	Solid State Load Contactor (M2)
1	PRD7AG0	Mechanical Load Contactor (PRD)
1	VJ1008HWPL1X004	Enclosure-NEMA 4x
2	8WA1808	End Stop
3	S261D20	20 amp Circuit Breaker (B1, B2, S)
6	8WA1204	Terminal Blocks (TB1, TB2)
1	MOV524V15	Metal Oxide Varistor (MOV)
1	SSPIGTAIL	20' Photocell Pigtail
1	B12J2K5	Resistor
12	8WA8-848-2AY	TB1, TB2 Labels
2	8WA1802	Rail Link

AA2-TSS CONTROLLER

7.0 SUGGESTED SPARE PARTS LIST

QTY	PART NUMBER	DESCRIPTION
1	6390-FAA (This replaces the 102FAA Photocell)	120 – 240V AC Photocell
1	PF-250 (This replaces the FS15530T)	Solid State Flasher (M1)
1	SF-250 (This replaces the FA1552 Module)	Solid State Load Contactor (M2)
2	S261D20	20 amp Breaker

TWR Lighting, Inc. **HARK**[®]

Enlightened Technology[®]

AA2-TSS CONTROLLER

Warranty & Return Policy

TWR Lighting[®], Inc. (“TWR[®]”) warrants its products (other than “LED Product”) against defects in design, material (excluding incandescent bulbs) and workmanship for a period ending on the earlier of two (2) years from the date of shipment or one (1) year from the date of installation.

TWR Lighting[®], Inc. (“TWR[®]”) warrants its “LED Product” against defects in design, material and workmanship for a period of five (5) years from the date of shipment. TWR[®], at its sole option, will, itself, or through others, repair, replace or refund the purchase price paid for “LED Product” that TWR[®] verifies as being inoperable due to original design, material, or workmanship. All warranty replacement “LED Product” is warranted only for the remainder of the original warranty of the “LED Product” replaced. Replacement “LED Product” will be equivalent in function, but not necessarily identical, to the replaced “LED Product.”

TWR Lighting[®], Inc. (“TWR[®]”) warrants its “LED Product” against light degradation for a period of five (5) years from the date of installation. TWR[®], at its sole option, will, itself, or through others, repair, replace, or refund the purchase price paid for “LED Product” that TWR[®] verifies as failing to meet 75% of the minimum intensity requirements as defined in the FAA Advisory Circular 150/5345-43G dated 09/26/12. All warranty replacement “LED Product” is warranted only for the remainder of the original warranty of the “LED Product” replaced. Replacement “LED Product” will be equivalent in function, but not necessarily identical, to the replaced “LED Product.”

Replacement parts (other than “LED Product”) are warranted for 90 days from the date of shipment.

Conditions not covered by this Warranty, or which might void this Warranty are as follows:

- x Improper Installation or Operation
- x Misuse
- x Abuse
- x Unauthorized or Improper Repair or Alteration
- x Accident or Negligence in Use, Storage, Transportation, or Handling
- x Any Acts of God or Nature
- x **Non-OEM Parts**

The use of Non-OEM parts or modifications to original equipment design will void the manufacturer warranty and could invalidate the assurance of complying with FAA requirements as published in Advisory Circular 150/5345-43.

TWR Lighting, Inc. **MARK**[®]

Enlightened Technology[®]

AA2-TSS CONTROLLER

Warranty & Return Policy (continued)

Field Service – Labor, Travel, and Tower Climb are not covered under warranty. Customer shall be obligated to pay for all incurred charges. An extensive network of certified and insured Service Representatives is available if requested.

Repair, Replacement or Product Return RMA Terms – You must first contact our Customer Service Department at **713-973-6905** to acquire a Return Merchandise Authorization (RMA) number in order to return the product(s). Please have the following information available when requesting an RMA number:

- x The contact name and phone number of the tower owner or
- x The contact name and phone number of the contractor
- x The site name and number
- x The part number(s)
- x The serial number(s) (if any)
- x A description of the problem
- x The billing information
- x The Ship To address

This RMA number must be clearly visible on the outside of the box. If the RMA number is not clearly labeled on the outside of the box, your shipment will be refused. Please ensure the material you are returning is packaged carefully. **The warranty is null and void if the product(s) are damaged in the return shipment.**

All RMAs must be received by TWR LIGHTING[®], INC., 10810 W. LITTLE YORK RD. #130, HOUSTON, TX 77041-4051, within 30 days of issuance.

Upon full compliance with the Return Terms, TWR[®] will replace, repair and return, or credit product(s) returned by the customer. It is TWR[®]'s sole discretion to determine the disposition of the returned item(s).

TWR Lighting, Inc. **HARK**[®]

Enlightened Technology[®]

AA2-TSS CONTROLLER

Warranty & Return Policy (continued)

RMA Replacements – Replacement part(s) will be shipped and billed to the customer for product(s) considered as Warranty, pending return of defective product(s). When available, a certified reconditioned part is shipped as warranty replacement with a Return Merchandise Authorization (RMA) number attached. Upon receipt of returned product(s), inspection, testing, and evaluation will be performed to determine the cause of defect. The customer is then notified of the determination of the testing.

- x Product(s) that is deemed defective and/or unrepairable and covered under warranty - a credit will be issued to the customer's account.
- x Product(s) found to have no defect will be subject to a **\$75.00 per hour testing charge (1 hour minimum), which will be invoiced to the customer.** At this time the customer may decide to have the tested part(s) returned and is responsible for the return charges.
- x Product(s) under warranty, which the customer does not wish returned, the customer will be issued a credit against the replacement invoice.

RMA Repair & Return – A Return Merchandise Authorization (RMA) will be issued for all part(s) returned to TWR[®] for repair. Upon receipt of returned product(s), inspection, testing, and evaluation will be performed to determine the cause of defect. The customer is then notified of the determination of the testing. If the returned part(s) is deemed unrepairable, or the returned part(s) is found to have no defect, the customer will be subject to a **\$75.00 per hour testing charge (1 hour minimum), which will be invoiced to the customer.** Should the returned parts be determined to be repairable, a written estimated cost of repair will be sent to the customer for their written approval prior to any work being performed. In order to have the tested part(s) repaired and/or returned, the customer must issue a purchase order and is responsible for the return shipping charges.

RMA Return to Stock – Any product order that is returned to TWR[®] for part(s) ordered incorrectly or found to be unneeded upon receipt by the customer, the customer may be required to pay a minimum **20% restocking fee.** Product returned for credit must be returned within 60-days of original purchase, be in new and resalable condition, and in original packaging. Once the product is received by TWR it's condition will be evaluated and a credit will be issued only once it is determined that the RMA Return Terms have been met.

Credits – Credits are issued once it is determined that all of the Warranty and Return Terms are met. All credits are processed on Fridays. In the event a Friday falls on a Holiday, the credit will be issued on the following Friday.

TWR Lighting, Inc. **MARK**[®]

Enlightened Technology[®]

AA2-TSS CONTROLLER

Warranty & Return Policy (continued)

Freight – All warranty replacement part(s) will be shipped via ground delivery and paid for by TWR[®]. Delivery other than ground is the responsibility of the customer.

REMEDIES UNDER THIS WARRANTY ARE LIMITED TO PROVISIONS OF REPLACEMENT PARTS AND REPAIRS AS SPECIFICALLY PROVIDED. IN NO EVENT SHALL TWR[®] BE LIABLE FOR ANY OTHER LOSSES, DAMAGES, COSTS, OR EXPENSES INCURRED BY THE CUSTOMER, INCLUDING, BUT NOT LIMITED TO, LOSS FROM FAILURE OF THE PRODUCT(S) TO OPERATE FOR ANY TIME, AND ALL OTHER DIRECT, INDIRECT, SPECIAL, INCIDENTAL, OR CONSEQUENTIAL DAMAGES, INCLUDING ALL PERSONAL INJURY OR PROPERTY DAMAGE DUE TO ALLEGED NEGLIGENCE, OR ANY OTHER LEGAL THEORY WHATSOEVER. THIS WARRANTY IS MADE BY TWR[®] EXPRESSLY IN LIEU OF ALL OTHER WARRANTIES, WHETHER EXPRESSED OR IMPLIED. WITHOUT LIMITING THE GENERALITY OF THE FORGOING, TWR[®] MAKES NO WARRANTY OF MERCHANTABILITY OR FITNESS OF THE PRODUCT(S) FOR ANY PARTICULAR PURPOSE. TWR[®] EXPRESSLY DISCLAIMS ALL OTHER WARRANTIES.

TWR Lighting, Inc. HARK[®]

Enlightened Technology[®]

AA2-TSS CONTROLLER

RETURN MERCHANDISE AUTHORIZATION (RMA) FORM

RMA#: _____ **DATE:** _____

CUSTOMER: _____

CONTACT: _____ **PHONE NO.:** _____

ITEM DESCRIPTION (PART NO.): _____

MODEL NO.: _____ **SERIAL NO.:** _____

ORIGINAL TWR INVOICE NO.: _____ **DATED:** _____

DESCRIPTION OF PROBLEM: _____

SIGNED: _____ **DATE NEEDED:** _____

RETURN ADDRESS: _____

PLEASE RETURN PRODUCT TO: 10810 W. LITTLE YORK RD., #130 HOUSTON, TX 77041-4051

TWR Lighting, Inc. HARK[®]

Enlightened Technology[®]

AA2-TSS CONTROLLER

RETURN MERCHANDISE AUTHORIZATION (RMA) FORM

RMA#: _____ **DATE:** _____

CUSTOMER: _____

CONTACT: _____ **PHONE NO.:** _____

ITEM DESCRIPTION (PART NO.): _____

MODEL NO.: _____ **SERIAL NO.:** _____

ORIGINAL TWR INVOICE NO.: _____ **DATED:** _____

DESCRIPTION OF PROBLEM: _____

SIGNED: _____ **DATE NEEDED:** _____

RETURN ADDRESS: _____

PLEASE RETURN PRODUCT TO: 10810 W. LITTLE YORK RD., #130 HOUSTON, TX 77041-4051

9"X7" PLATE

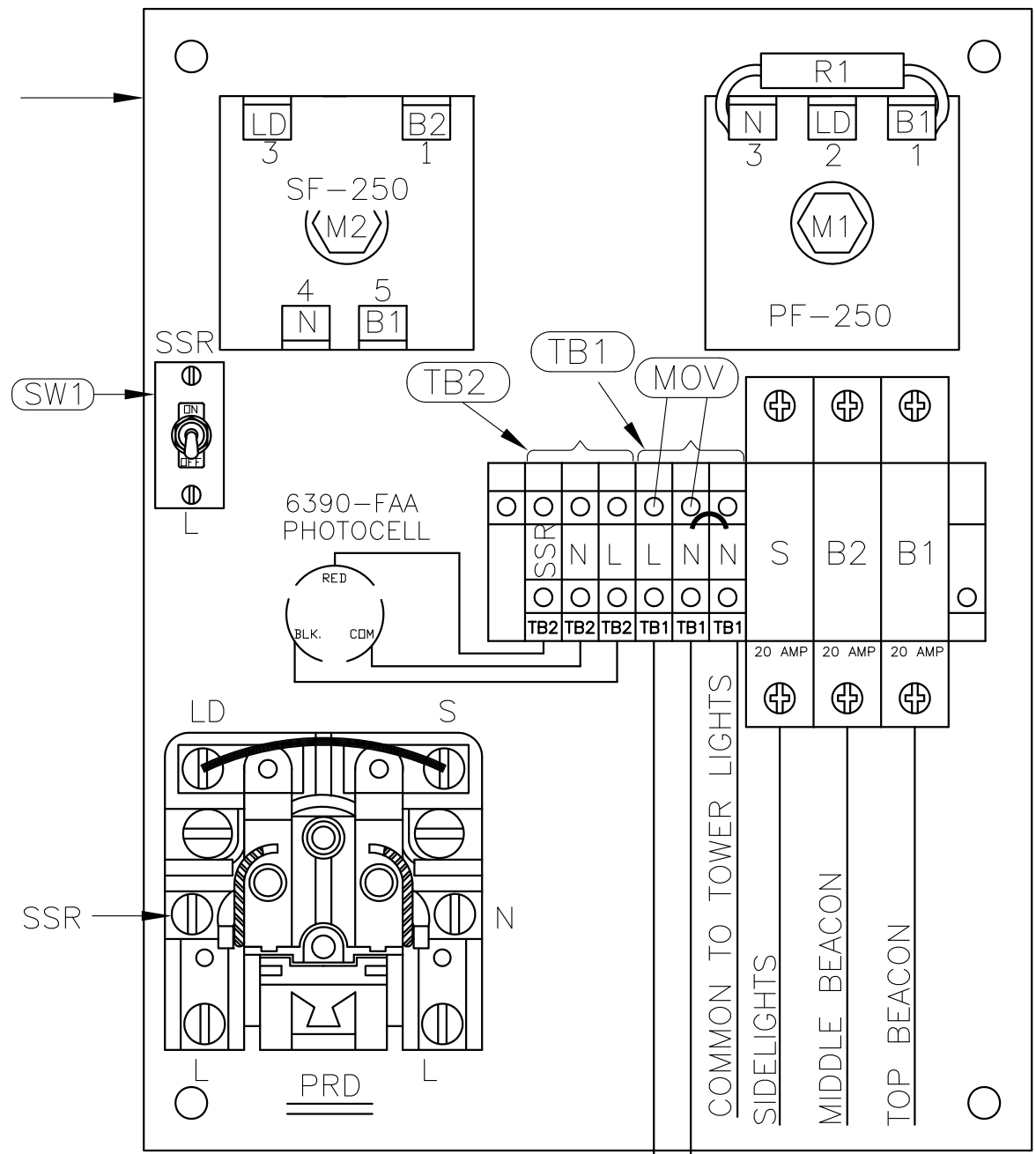

120 VAC
50/60Hz

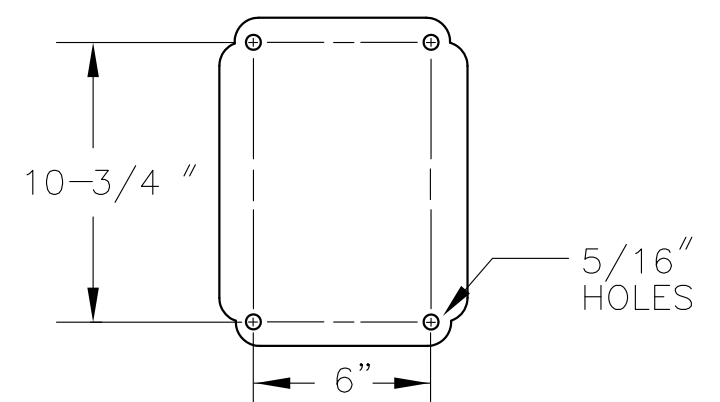

MOUNTING DIMENSIONS
(FOR CABINET)

NOTES:

1. WHEN REPLACING MODULES USE HEAT SINK COMPOUND BETWEEN MODULE AND ALUMINUM PLATE.
2. WIRES ARE CONNECTED LETTER TO LETTER. (EXAMPLE) LD TO LD TO LD.

AA2-TSS CONTROLLER LAYOUT			
PROD DEPT	TWR Lighting, Inc. <i>Enlightened Technology</i> WORK		
SERV DEPT			
ENGINEER			
DRAWN BY E.A.SALAZAR	SHEET SIZE B	SHEET QTY. 1 OF 1	1
DATE 05/08/91	SCALE 3/4" = 1"	DWG. NO.	203-R

3/31/2009		UPDATE CONTROLLER
DATE:	LTR.	REVISION

The use of non-OEM parts or modifications to original equipment design will void the manufacturer warranty and could invalidate the assurance of complying with FAA requirements as published in Advisory Circular 150/5345-43.
NOTICE: The drawings and photographic images contained herein are the sole property of TWR Lighting, Inc. All information contained herein that is not generally known shall be considered confidential except to the extent the information has been previously established. The drawings and photographic images contained herein may not be reproduced, copied or used as the basis for manufacture or sale or promotion or any other purpose without the expressed written permission of TWR Lighting, Inc.

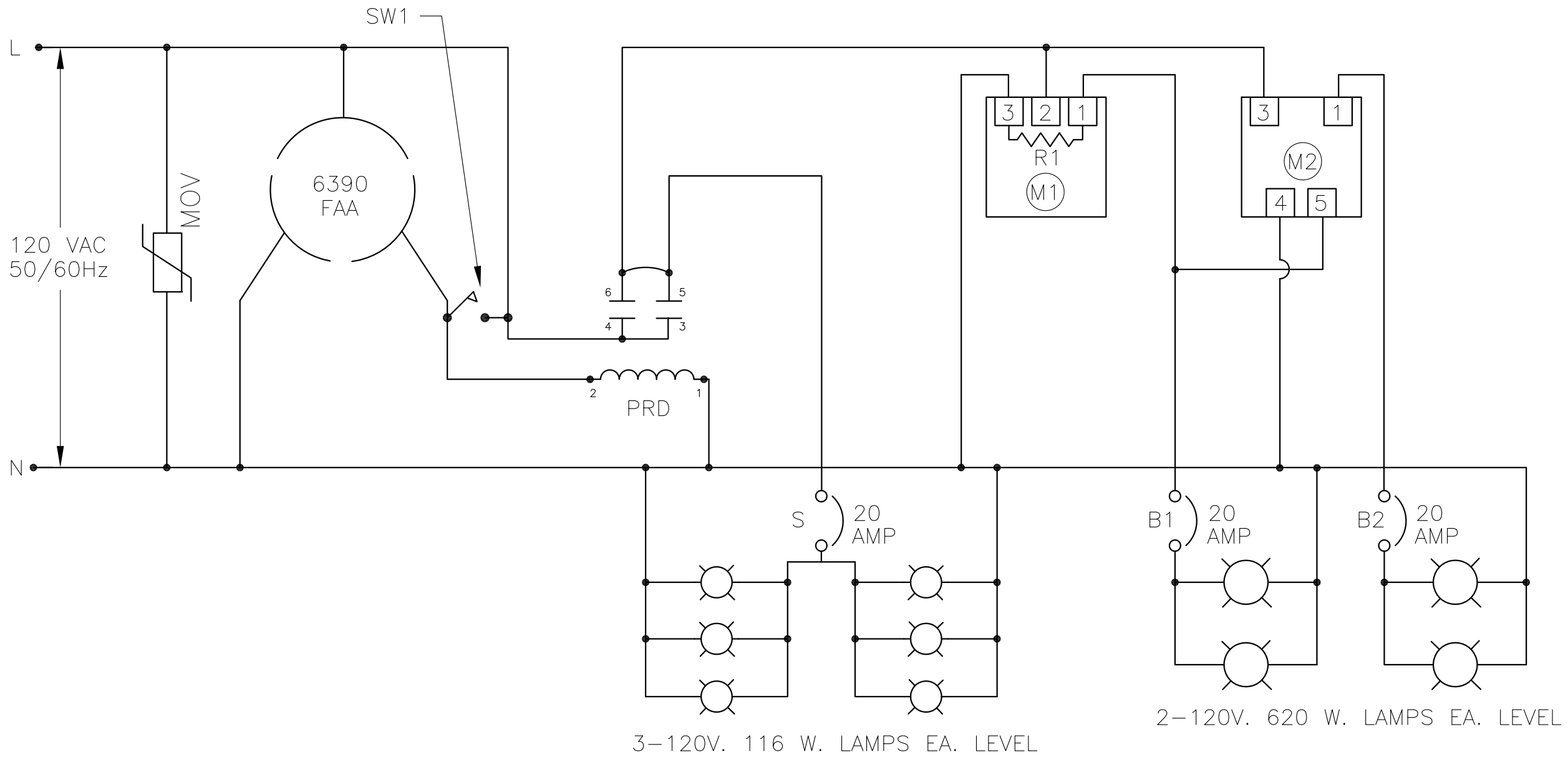

AA2-TSS SCHEMATIC

PROD DEPT	TWR Lighting, Inc. Enlightened Technology®		
SERV DEPT			
ENGINEER			
DRAWN BY E.A.SALAZAR	SHEET SIZE B	SHEET QTY. 1 OF 1	
DATE 06/03/92	SCALE N.T.S.	DWG. NO. 203-S	

3/31/2009		UPDATED DWG.
DATE:	LTR.	REVISION

The use of non-OEM parts or modifications to original equipment design will void the manufacturer warranty and could invalidate the assurance of complying with FAA requirements as published in Advisory Circular 150/5345-43.
NOTICE: The drawings and photographic images contained herein are the sole property of TWR Lighting, Inc. All information contained herein that is not generally known shall be considered confidential except to the extent the information has been previously established. The drawings and photographic images contained herein may not be reproduced, copied or used as the basis for manufacture or sale or promotion or any other purpose without the expressed written permission of TWR Lighting, Inc.

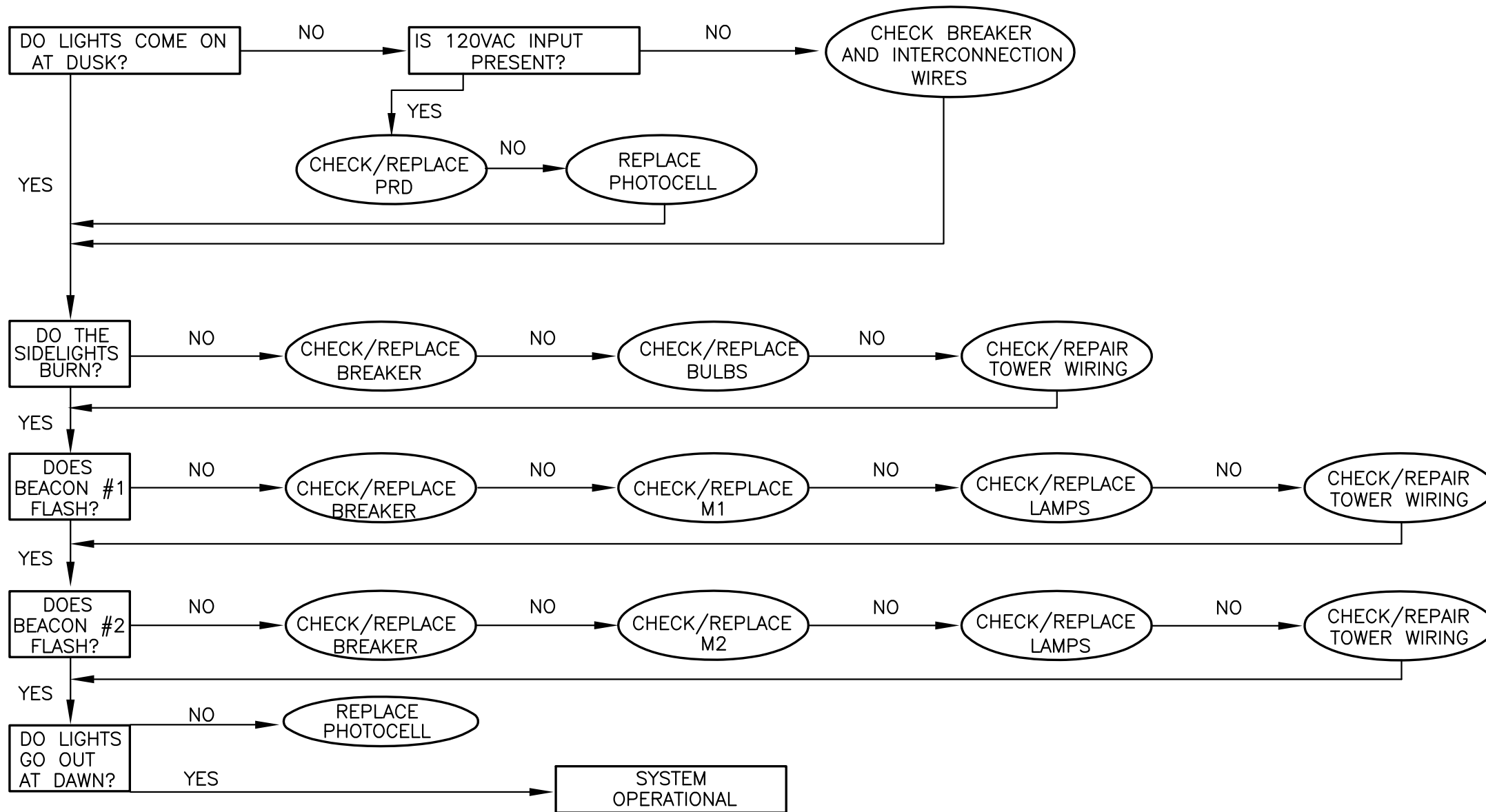

TROUBLESHOOTING FLOW CHART			
AA2-TSS DWG.#203-R			
PROD DEPT	TWR Lighting, Inc. <i>Enlightened Technology®</i>		
SERV DEPT			
ENGINEER			
DRAWN BY	E.A.SALAZAR	SHEET SIZE	SHEET QTY.
DATE	06/09/95	SCALE	N.T.S.
		B	1 OF 1
		DWG. NO.	203-F
<small>The use of non-OEM parts or modifications to original equipment design will void the manufacturer warranty and could invalidate the assurance of complying with FAA requirements as published in Advisory Circular 150/5345-43.</small>			
<small>NOTICE: The drawings and photographic images contained herein are the sole property of TWR Lighting, Inc. All information contained herein that is not generally known shall be considered confidential except to the extent the information has been previously established. The drawings and photographic images contained herein may not be reproduced, copied or used as the basis for manufacture or sale or promotion or any other purpose without the expressed written permission of TWR Lighting, Inc.</small>			

12/14/04	(A)	UPG. TO BREAKERS
DATE:	LTR.	REVISION

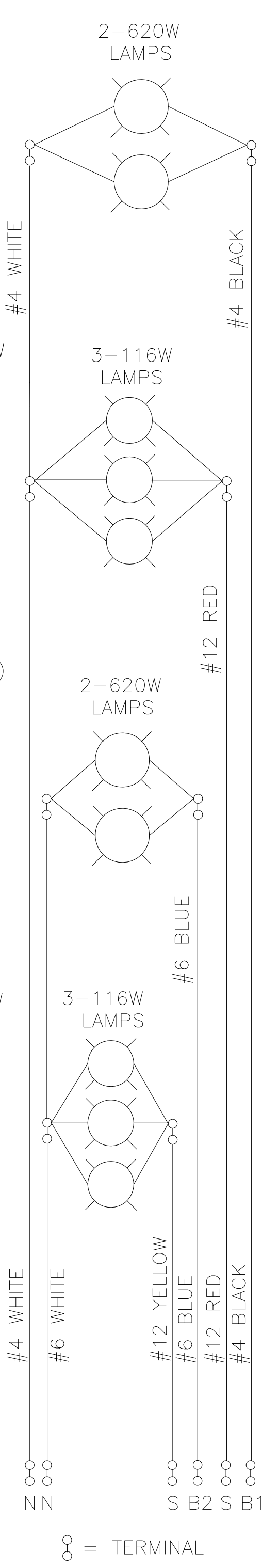
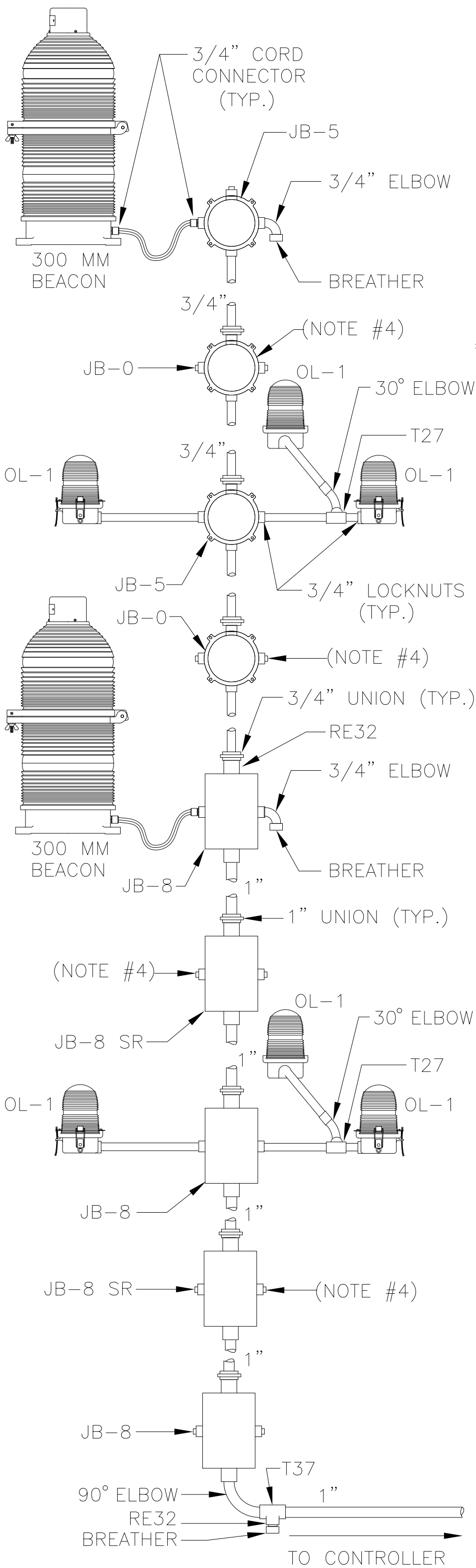

NOTES:

- 1) CONDUIT SIZE BASED ON USING TYPE THHN WIRE.
- 2) USE RIGID GALVANIZED STEEL CONDUIT.
- 3) BREATHERS ALLOW FOR CIRCULATION OF AIR TO PREVENT CONDENSATION.
- 4) USE STRAIN RELIEF BOXES ON TOWERS OVER 400'.

A2 TOWER LIGHTING KIT (FOR 350' TO 500' TOWERS)		DRAWING NO. 361-2	
		MATERIAL	
		SCALE N.T.S.	DATE 10/14/91
DRAWN BY G.D. SEBEK	CHK'D BY	TRACED	APP'D

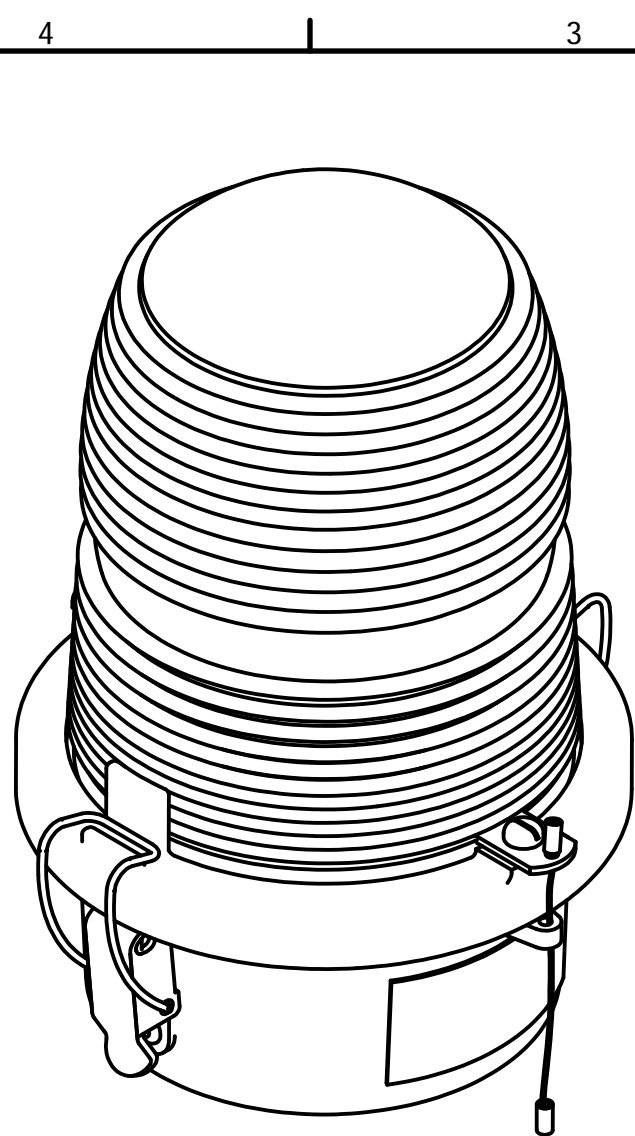

PARTS LIST			
ITEM	QTY	PART NUMBER	DESCRIPTION
1	1	AP35222	RED SIDELIGHT GLASS
2	1	105C	SINGLE SIDELIGHT BODY
3	1	106C	LENS HOLDER RING
4	2	12V245	OL LENS CLIP
5	2	832X14PH	8-32 X 1/4" PH SS SLOT SCREW
6	2	HC255SS	SIDELIGHT LATCH
7	1	7X7SS	1/16 HOL 7X7 S.S. WIRE
8	2	A1A	STAKON CRIMP
9	1	OLG	OL GASKET
10	1	TWR19062	SIDELIGHT RECEPTACLE
11	4	18PRSS	1/8 X .40 SS POP RIVET
12	1	A314	3/4" CONDUIT LOCKNUT GALV.
*	2	104G	WHITE TEFLON WASHER
14	2	832X34PH	8-32 X 3/4" S.S. RH SLOT
15	1	100327	OL1 SERIAL NUMBER LABEL
~	1	116A21TS	116W-120V LAMP (TYP.)

* = PART NOT SHOWN
 ~ = PART SOLD SEPARATELY

NOTE:
 1. FAA APPROVED LIGHT USES THE 116A21TS LAMP.
 OTHER LAMPS ARE AVAILABLE TO MEET YOUR APPLICATION.

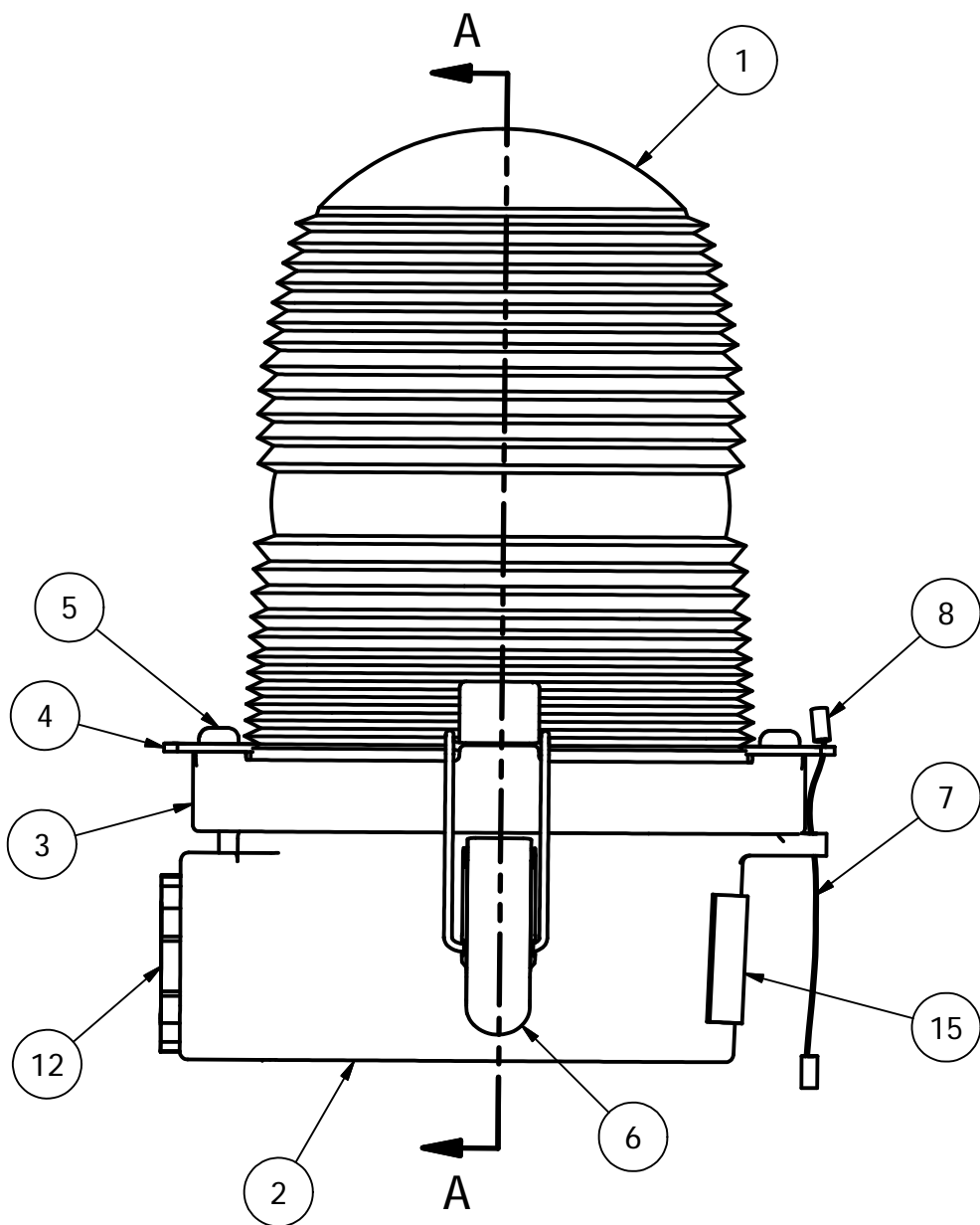

SECTION A-A

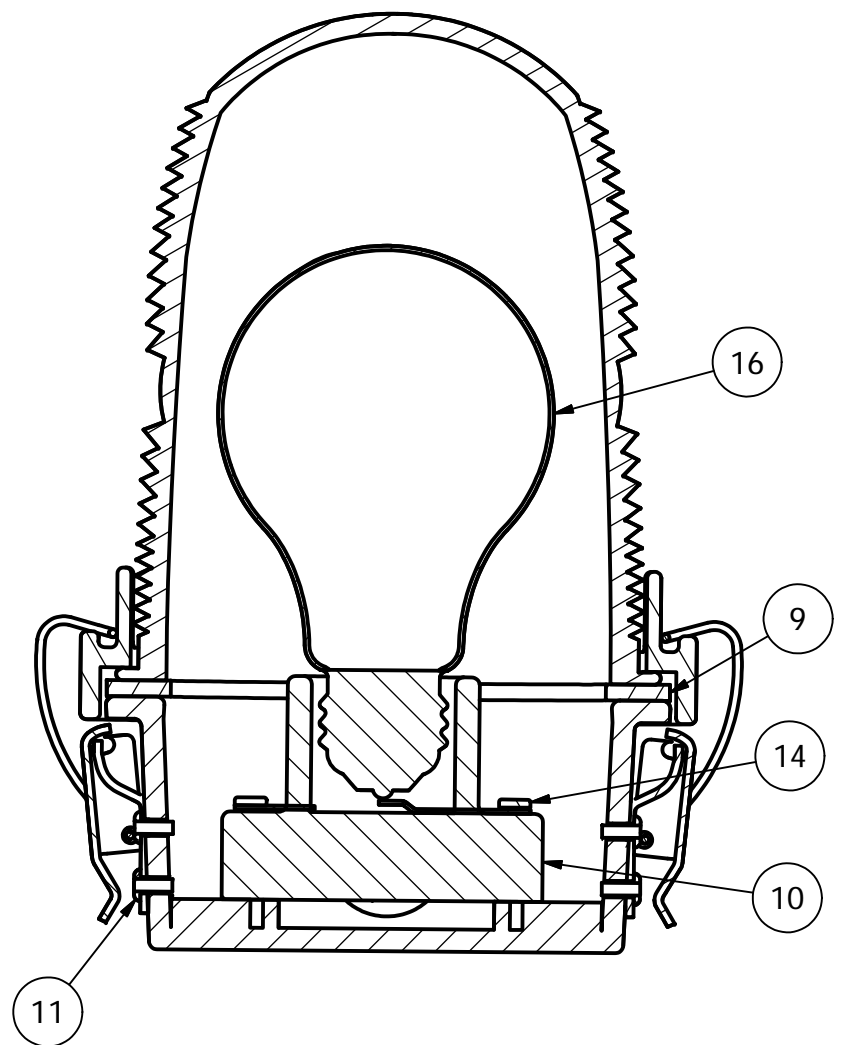

DRAWN	vhernandez	2/13/2012
CHECKED		
QA		
MFG		
APPROVED		

TWR Lighting, Inc.
Enlightened Technology

TITLE
 3/4" OL1 SIDE HUB
 ASSEMBLY DETAIL (PART#OL1)

SIZE	B	DWG NO	279-OL	REV	C
SCALE	2/3	SHEET 1 OF 1			

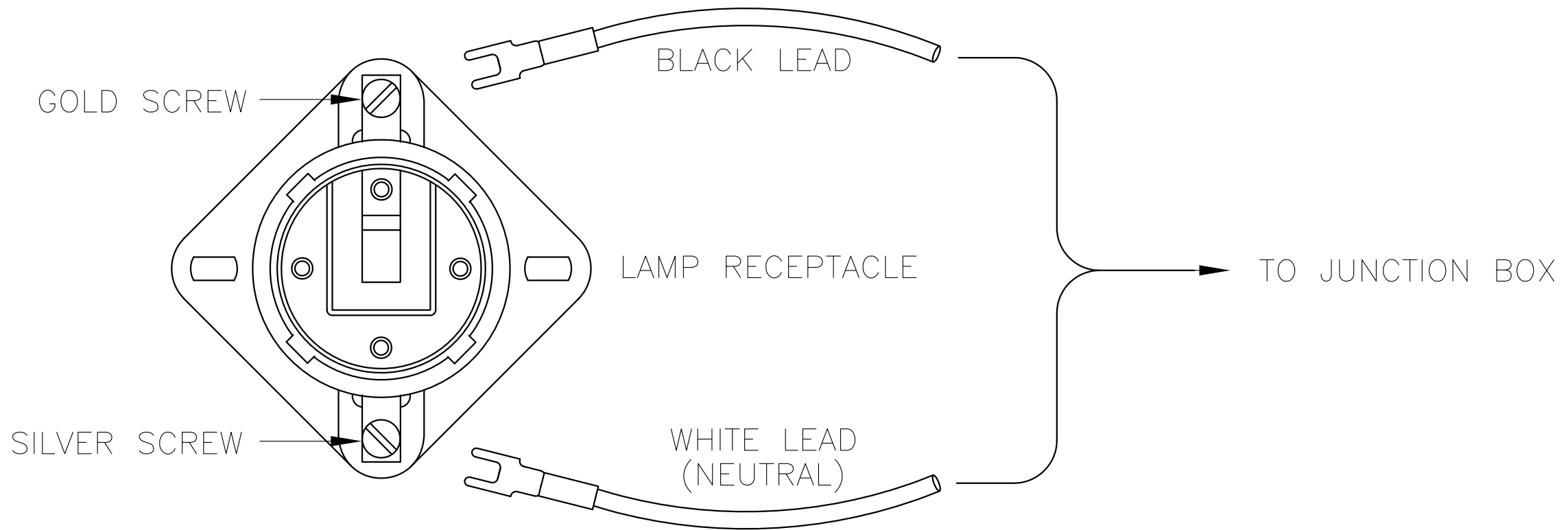

SIDELIGHT RECEPTACLE WIRING			
PROD DEPT	TWR Lighting, Inc. <i>Enlightened Technology</i> WORK		
SERV DEPT			
ENGINEER			
DRAWN BY	G.D. SEBEK	SHEET SIZE	SHEET QTY.
DATE	06/08/91	B	1 OF 1
		SCALE	DWG. NO.
		N.T.S.	274-S

7/2/98	(A)	CHANGED LABEL
DATE:	LTR.	REVISION

NOTICE: The drawings and photographic images contained herein are the sole property of TWR Lighting, Inc. All information contained herein that is not generally known shall be considered confidential except to the extent the information has been previously established. The drawings and photographic images contained herein may not be reproduced, copied or used as the basis for manufacture or sale or promotion or any other purpose without the expressed written permission of TWR Lighting, Inc.

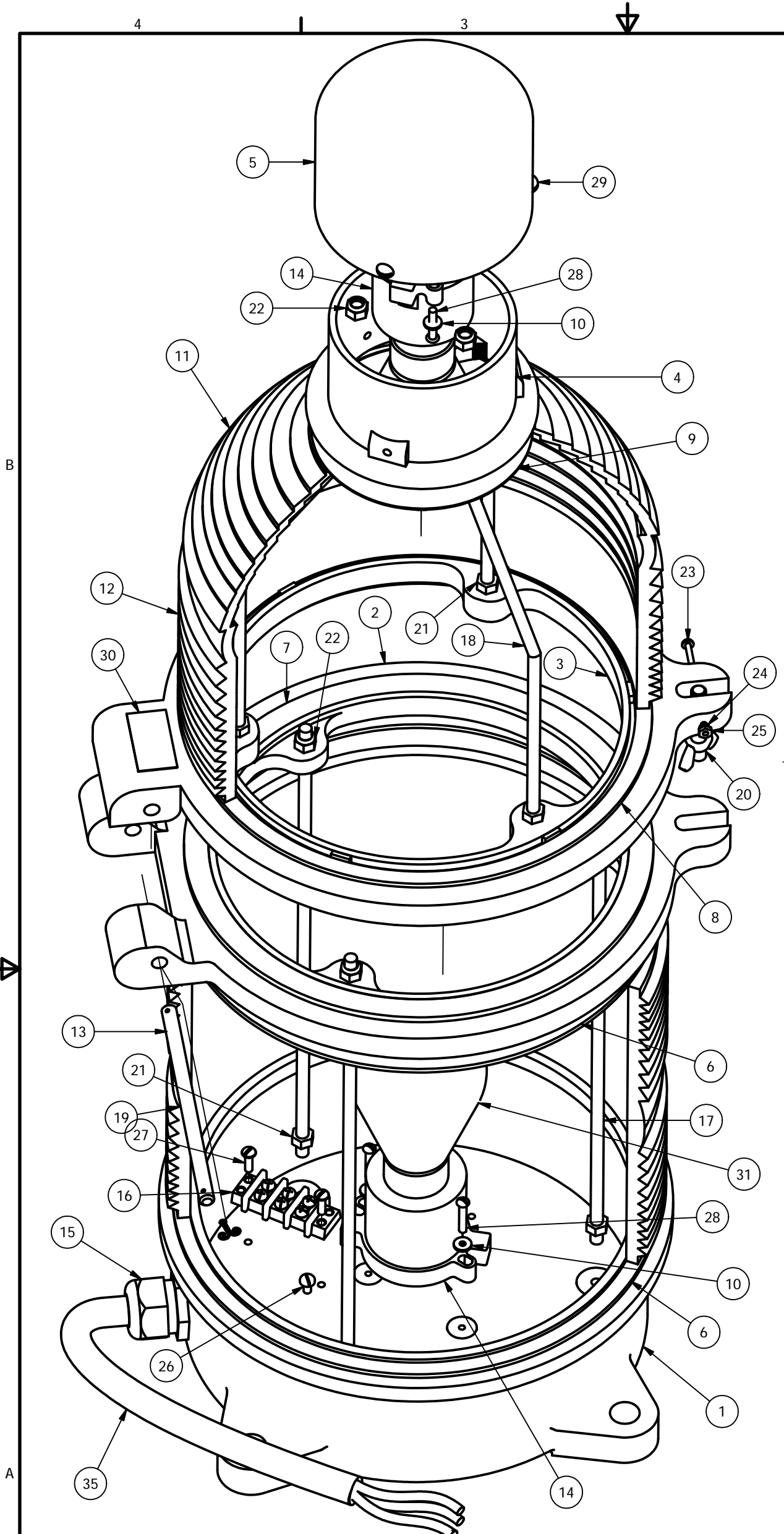

Parts List			
ITEM	QTY	PART NUMBER	DESCRIPTION
1	1	100C	BEACON BASE
2	1	101C	LOWER HINGE
3	1	102C	UPPER HINGE
4	1	103C	CANOPY CAP
5	1	104C	CANOPY FLANGE
6	2	100G	GASKET BEACON BASE
7	1	101G	GASKET MIDDLE BEACON
8	1	102G	GASKET, TOP HINGE
9	1	103G	GASKET TEFLON, TOP
10	4	104G	WHITE TEFLON WASHER
11	1	AP3557	CAP LENS RED
12	1	AP3556	MIDDLE LENS RED
13	2	AP3555	BOTTOM LENS RED
14	2	TWR23-546	BEACON LAMP RECEPTACLE
15	1	CGB295SA	3/4" CORD CONNECTOR .62 TO .75
16	1	TERMBLK3	TERMINAL BLOCK 3-PART
17	3	BTRS-1	BEACON TIE ROD STRAIGHT
18	3	BTRB	BEACON TIE ROD BENT
19	1	BHP	BEACON HINGE PIN W/ COTTER PIN
20	1	BLP	BEACON LATCH PIN
21	6	516NUT	5/16-15 HEX NUT
22	6	516NUTN	5/16-18 NUT W/NYLON INSERT
23	1	632X2RH	6-32 X 2 SS RH SLOT SCREW
24	1	632LW	6-32 LOCK WASHER
25	1	632NUT	6-32 NUT HEX
26	1	1032x38BH	10-32 X 3/8 PILLIPS PAN HEAD
27	2	1032x58PH	10-32 X 5/8 PH SLOT SCREW
28	4	1032X1RH	10-32 X 1 SS RH SCREW
29	3	1420X58RH	14-20 X 5/8 RH SLOT SCREW
30	1	100328	BEACON SERIAL NUMBER LABEL
31	2	---	BEACON LAMP
*	32	7	TYZ23M HI TEMP TY WRAPS T&B TEFZEL
*	33	4'	16HTWH #16 HI-TEMP WIRE SRML WHITE
*	34	4'	16HTBL #16 HI-TEMP WIRE SRML BLACK
35	5'	CSO14/3	S.O. CORD 14AWG/3 CONDUCTOR
*	36	11	YAV14-H34F (STAKON) BURNDY HEAVY DUTY

* = ITEMS NOT SHOWN
 ~ = PART SOLD SEPARATELY

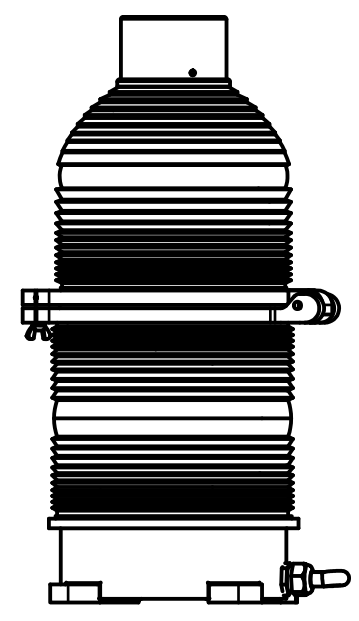

DRAWN J.L.BUSTAMANTE	11/27/07	TWR Lighting, Inc. <i>Enlightened Technology®</i> 300 MM BEACON ASSEMBLY DETAIL		
CHECKED				
QA				
MFG				
APPROVED				
		SIZE B	DWG NO 275-B	REV E
		SCALE	SHEET 1 OF 1	

The use of non-OEM parts or modifications to original equipment design will void the manufacturer warranty and could invalidate the assurance of complying with FAA requirements as published in Advisory Circular 150/5345-43. NOTICE: The drawings and photographic images contained herein are the sole property of TWR Lighting, Inc. All information contained herein that is not generally known shall be considered confidential except to the extent the information has been previously established. The drawings and photographic images contained herein may not be reproduced, copied or used as the basis for manufacture or sale or promotion or any other purpose without the expressed written permission of TWR Lighting, Inc.

- 1) WHITE WIRE IS NEUTRAL TO BOTH LAMPS.
- 2) BLACK WIRE IS LINE TO BOTH LAMPS.
- 3) GREEN WIRE IS EARTH GROUND.

300 MM BEACON

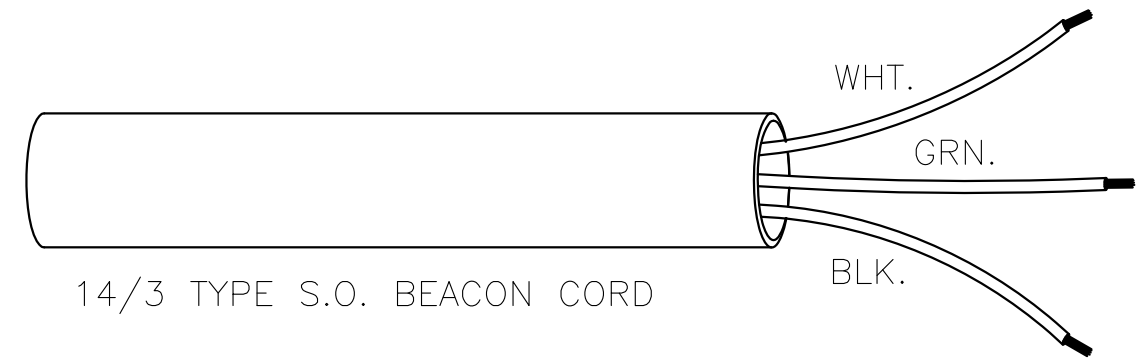
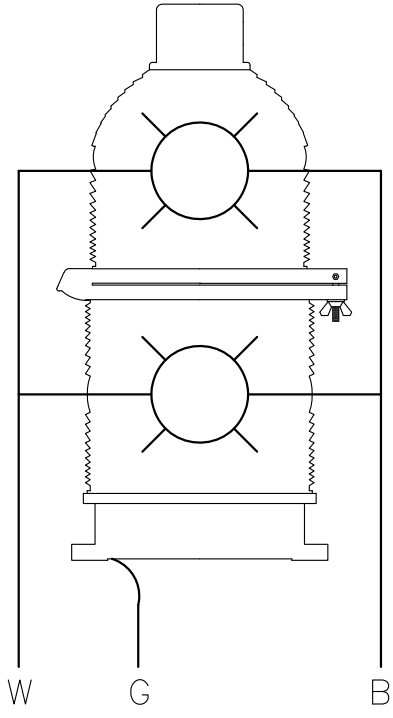

300 MM BEACON WIRE

PROD DEPT	TWR Lighting, Inc. <i>Enlightened Technology®</i>				
SERV DEPT					
ENGINEER					
DRAWN BY	G.D. SEBEK	SHEET SIZE	B	SHEET QTY.	1 OF 1
DATE	6/10/91	SCALE	N.T.S.	DWG. NO.	273-B

The use of non-OEM parts or modifications to original equipment design will void the manufacturer warranty and could invalidate the assurance of complying with FAA requirements as published in Advisory Circular 150/5345-43.
 NOTICE: The drawings and photographic images contained herein are the sole property of TWR Lighting, Inc. All information contained herein that is not generally known shall be considered confidential except to the extent the information has been previously established. The drawings and photographic images contained herein may not be reproduced, copied or used as the basis for manufacture or sale or promotion or any other purpose without the expressed written permission of TWR Lighting, Inc.

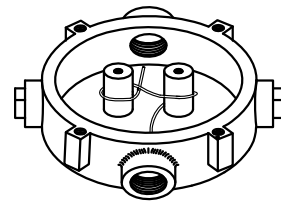
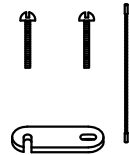
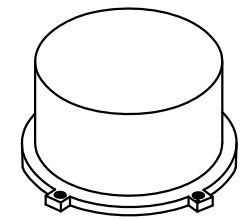
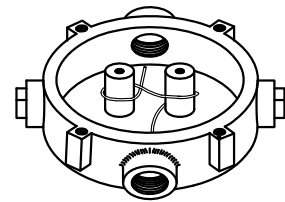
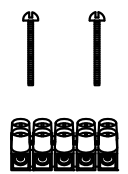
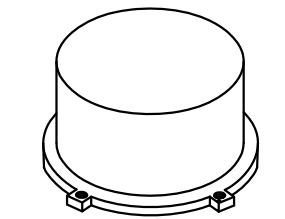

JB-5 AND JB-0
3/4" JUNCTION BOX

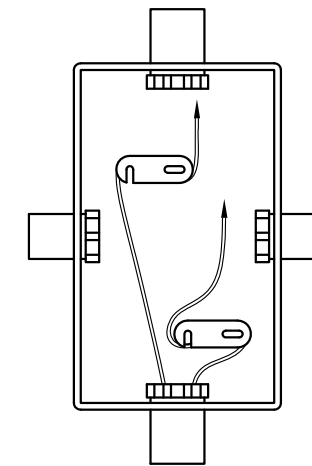
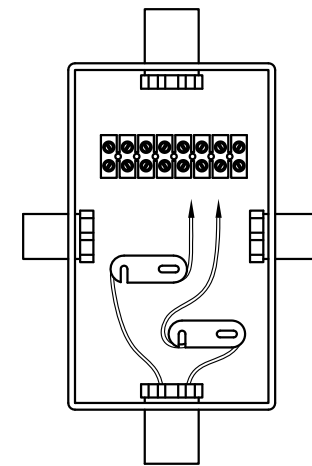

JB-8 AND JB-8SR
1" JUNCTION BOX

NOTES:

- 1) DRAWING ILLUSTRATES METHOD OF STRAIN RELIEVING WIRE. USE THIS METHOD ON ALL JUNCTION BOXES.
- 2) THE NATIONAL ELECTRICAL CODE-ARTICLE 300-19-B3 REQUIRES CONDUCTORS IN A VERTICAL CONDUIT BE SUPPORTED TO RELIEVE STRAIN ON TERMINAL BLOCK CONNECTIONS.
- 3) SKETCH ILLUSTRATES METHOD OF STRAIN RELIEVING A SINGLE CONDUCTOR. SEVERAL CONDUCTORS MAY BE GROUPED TOGETHER.
- 4) CONDUCTORS MAY BE MIXED BUT SHOULD NOT TAKE UP MORE THAN 40% OF CONDUIT'S INSIDE AREA.

USING THIS JUNCTION BOX METHOD SPACING IS 100 FEET MAXIMUM.

AWG WIRE SIZE	MAX. NUMBER WIRES IN 3/4" CONDUIT	MAX. NUMBER WIRES IN 1" CONDUIT	WIRE AREA SQ. INCHES	WEIGHT PER 100 FEET
12 THHN	16	26	0.0117	2.50
10 THHN	10	17	0.0184	4.10
8 THHN	6	9	0.0373	6.70
6 THHN	4	7	0.0519	10.30
4 THHN	2	4	0.0845	16.20

<u>JUNCTION AND STRAIN RELIEF BOXES</u>					
PROD DEPT	TWR Lighting, Inc. <i>Enlightened Technology®</i>				
SERV DEPT					
ENGINEER					
DRAWN BY	G.D. SEBEK	SHEET SIZE	B	SHEET QTY.	1 OF 1
DATE	07/26/93	SCALE	N.T.S.	DWG. NO.	100089

9/29/00	(A)	UPDATED NOTES
DATE:	LTR.	REVISION

The use of non-OEM parts or modifications to original equipment design will void the manufacturer warranty and could invalidate the assurance of complying with FAA requirements as published in Advisory Circular 150/5345-43.
NOTICE: The drawings and photographic images contained herein are the sole property of TWR Lighting, Inc. All information contained herein that is not generally known shall be considered confidential except to the extent the information has been previously established. The drawings and photographic images contained herein may not be reproduced, copied or used as the basis for manufacture or sale or promotion or any other purpose without the expressed written permission of TWR Lighting, Inc.

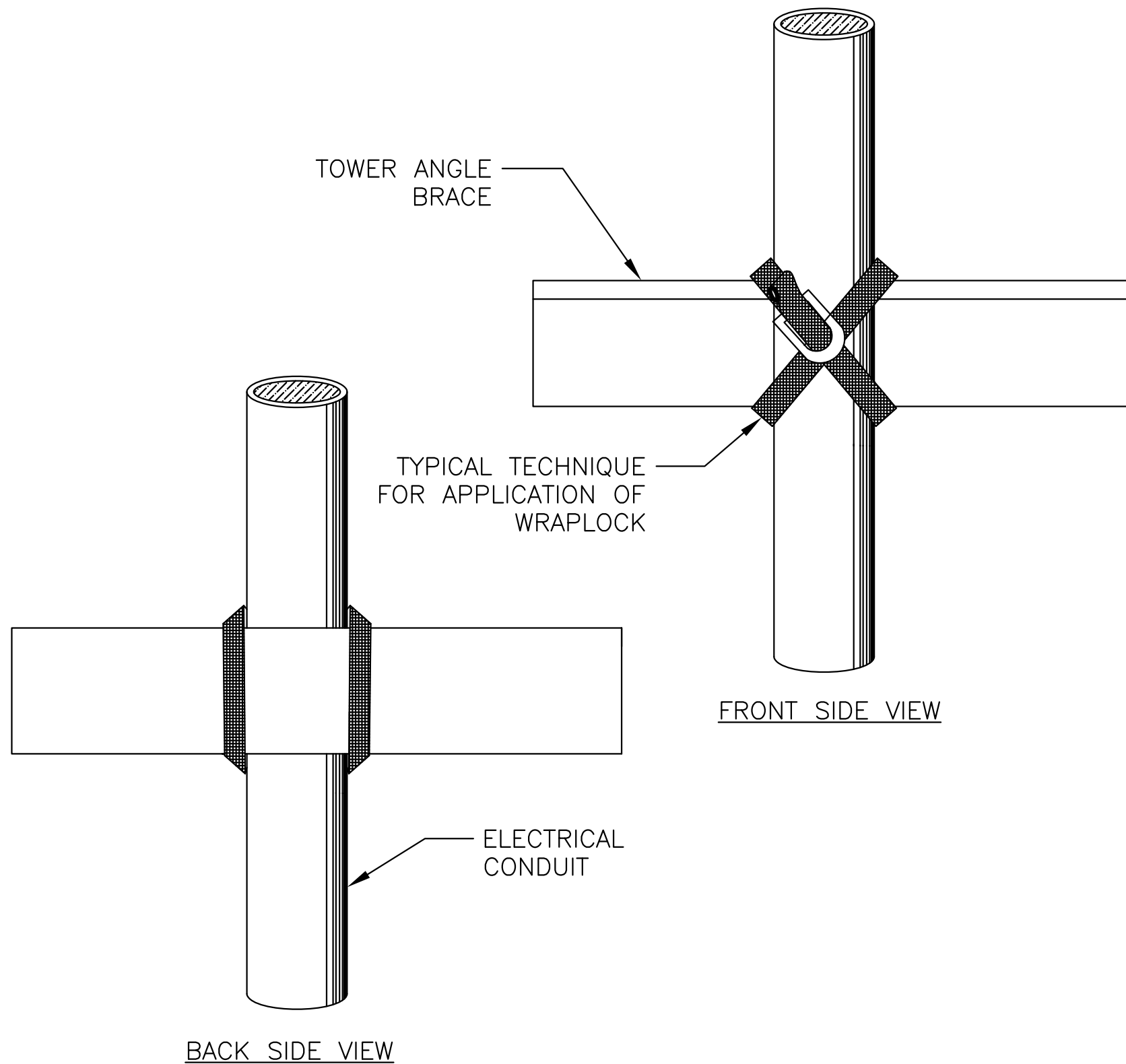

**DIRECTIONS FOR USING
WrapLock**
CUT OFF BAND TO PROPER LENGTH.
(SEE TABLE ON COVER OF BOX)

- 1.— PASS ONE END THROUGH YOKE AND BEND BACK ABOUT 1 1/2" AND FLATTEN DOWN.
- 2.— PASS BAND AROUND WORK AND THROUGH YOKE.
- 3.— REPEAT AND PASS END THROUGH A SECOND TIME, DRAW UP FREE END SNUGLY WITH PLIERS.



- 4.— INSERT FREE END IN SLOT OF RATCHET.
- 5.— TURN DOWN UNTIL CLAMP IS TIGHT.
- 6.— BACK OFF SLIGHTLY TO REMOVE RATCHET. CLAMP IS NOW SECURELY LOCKED.

TO REMOVE WrapLock
UNCOIL END WITH RATCHET. PRESS DOWN AT POINT WHERE BAND METAL HAS BEEN FORCED THROUGH CURVED PART OF YOKE.

WRAPLOCK FASTENING DETAIL

ENGINEER	TWR Lighting, Inc. <i>Enlightened Technology®</i>		
APPROVED			
APPROVED			
APPROVED	DRAWN BY M. PETERMAN	SHEET SIZE B	SHEET QTY. 1 OF 1
APPROVED	DATE 05/01/2014	SCALE N.T.S.	DWG. NO. 100984

The use of non-OEM parts or modifications to original equipment design will void the manufacturer warranty and could invalidate the assurance of complying with FAA requirements as published in Advisory Circular 150/5345-43.
NOTICE: The drawings and photographic images contained herein are the sole property of TWR Lighting, Inc. All information contained herein that is not generally known shall be considered confidential except to the extent the information has been previously established. The drawings and photographic images contained herein may not be reproduced, copied or used as the basis for manufacture or sale or promotion or any other purpose without the expressed written permission of TWR Lighting, Inc.