

TWR Lighting, Inc. **MARK**[®]

Enlightened Technology[®]

4300 WINDFERN RD STE 100 HOUSTON, TX 77041-8943
VOICE: 713/973-6905 FAX: 713/973-9352
web: www.twrlighting.com

IMPORTANT!!!

PLEASE TAKE THE TIME TO FILL OUT THIS FORM COMPLETELY. FILE IT IN A SAFE PLACE. IN THE EVENT YOU EXPERIENCE PROBLEMS WITH OR HAVE QUESTIONS CONCERNING YOUR CONTROLLER, THE FOLLOWING INFORMATION IS NECESSARY TO OBTAIN PROPER SERVICE AND PARTS.

MODEL # E2/3DB

SERIAL # _____

PURCHASE DATE _____

PURCHASED FROM _____

TWR Lighting, Inc. **HARK**

Enlightened Technology

E2/3DB CONTROLLER

TABLE OF CONTENTS

1.0	INTRODUCTION	1
1.1	APPLICATION.....	1
1.2	SPECIFICATIONS OF EQUIPMENT.....	1
2.0	INSTALLATION	2
2.1	POWER SUPPLY CONTROL CABINET MOUNTING	2
2.2	PHOTOCELL HOUSING	2
2.3	PHOTOCELL WIRING	3
2.4	POWER WIRING.....	3
2.5	TOWER LIGHTING KIT.....	4
2.5.1	BEACON MOUNTING AND WIRING	4
2.5.2	LIGHTING KIT WIRING	5
2.6	ALARM WIRING.....	8
2.6.1	WHITE STROBE #1 FAILURE (ST1).....	8
2.6.2	WHITE STROBE #2 FAILURE (ST2).....	8
2.6.3	WHITE STROBE #3 FAILURE (ST3).....	8
2.6.4	RED STROBE FAILURE (RF).....	9
2.6.5	POWER FAILURE (PF).....	9
2.6.6	PHOTOCELL (PC)	9
2.6.7	SIDELIGHT #1 ALARM (SA1).....	9
2.6.8	SIDELIGHT #2 ALARM (SA2).....	9
2.7	ALARM TESTING.....	10
2.7.1	WHITE STROBE FAILURE (ST1, ST2, and ST3)	10
2.7.2	RED STROBE FAILURE (RF).....	10
2.7.3	POWER FAILURE (PF).....	10
2.7.4	PHOTOCELL (PC)	10
2.7.5	SIDELIGHT #1 ALARM (SA1).....	10
2.7.6	SIDELIGHT #2 ALARM (SA2).....	11
2.8	CONTROLLER CONFIGURATION	11
3.0	THEORY OF OPERATION	12
3.1	THE POWER SUPPLY	12
3.2	THE FLASHTUBE	12
3.3	TIMING CIRCUIT.....	13
3.4	TRIGGER CIRCUIT	13
3.5	ALARM CIRCUITS	14
3.5.1	WHITE STROBE FAILURE (ST1, ST2, and ST3)	14
3.5.2	RED STROBE FAILURE (RF).....	14

TWR Lighting, Inc. HARK[®]

Enlightened Technology[®]

E2/3DB CONTROLLER

3.5.3	POWER FAILURE (PF).....	14
3.5.4	PHOTOCELL (PC)	14
3.5.5	SIDELIGHT ALARM (SA1 and SA2)	14
3.6	BLEEDER CIRCUIT	15
3.7	STROBE DIAGNOSTIC CIRCUITS.....	15
3.7.1	CONTROL POWER ON	15
3.7.2	HIGH VOLTAGE	16
3.7.3	TRIGGER VOLTAGE	16
3.7.4	NIGHTMODE.....	16
3.7.5	PRIMARY TIMING.....	16
3.7.6	TIMING SIGNAL VERIFY.....	16
3.7.7	FLASH VERIFIED	17
3.7.8	STROBE FAIL TEST.....	17
4.0	TROUBLESHOOTING	18
4.1	TOOL REQUIREMENTS	18
4.2	DIAGNOSTIC EVALUATION	18
4.3	TROUBLESHOOTING ASSISTANCE.....	19
4.3.1	FLASH VERIFY LED – OUT	19
4.3.2	CONTROL POWER ON LED – OUT	19
4.3.3	PRIMARY TIMING LED – OUT	19
4.3.4	FALSE OR NONEXISTENT BEACON ALARMS (ST1, ST2, and ST3)	19
4.3.5	FALSE OR NONEXISTENT BEACON ALARM (RF)	20
4.3.6	NO RED STROBE OPERATION.....	20
5.0	MAINTENANCE GUIDE	21
5.1	FLASHTUBE REPLACEMENT	21
5.2	RED OBSTRUCTION LIGHTING	22
5.2.1	LAMP REPLACEMENT.....	22
5.3	POWER SUPPLY	23
5.4	PHOTOCELL.....	23
6.0	MAJOR COMPONENTS LIST	24
7.0	SUGGESTED SPARE PARTS LIST	29

WARRANTY & RETURN POLICY

RETURN MERCHANDISE AUTHORIZATION (RMA) FORM

TWR Lighting, Inc. HARK[®]

Enlightened Technology[®]

E2/3DB CONTROLLER

APPENDIX

CHASSIS COMPONENT LAYOUT.....	H40-279 (REV J)
SCHEMATIC LAYOUT	M01-279 (REV F)
HOUSING DETAIL.....	HD0-279 (REV C)
INSTALLATION GUIDELINE.....	INS-279 (REV A)
PHOTOCELL HOUSING DETAIL.....	100239 (REV H)
TOWER LIGHTING KIT 351' TO 500'	601 (REV E)
TOWER LIGHTING KIT 351' TO 500' CONDUIT/CABLE.....	601-01 (REV D)
SIDELIGHT MOUNT ASSEMBLY	100489 (REV A)
TIMING/CONTROL PCB	H01-279 (REV C)
HIGH VOLTAGE RECTIFIER PCB.....	H02-258 (REV B)
RELAY PCB w/ALARM LOCKOUT ELIMINATION MODIFICATION	H03-279A
TRIGGER VOLTAGE RECTIFIER PCB	H04-269
L-810 OL-1 SINGLE OBSTRUCTION LIGHT	FM10018 (REV C)
L-810 OL-1 SINGLE OBSTRUCTION LIGHT DETAIL.....	279-OL (REV B)
L-810 OL-1 SINGLE OBSTRUCTION WIRING DETAIL	274-S (REV A)
JUNCTION BOX DETAIL	100089 (REV A)
STD BEACON ASSEMBLY.....	100414 (REV B)

TWR Lighting, Inc. HARK®

Enlightened Technology®

E2/3DB CONTROLLER

1.0 INTRODUCTION

The TWR Lighting®, Inc. (TWR®) Model E2/3DB Type L-864/L-865 Controller has been designed and built to the Federal Aviation Advisory Circular 150/5345-43E with safety and reliability in mind. TWR® is committed to providing our customers with some of the best products and services available. TWR® welcomes you to our family of fine products and we look forward to servicing your needs now and in the future. **NOTE:** Structures exceeding 500' will require to be painted, in addition to this lighting, for added visual hazard marking.

1.1 APPLICATION

The E2/3DB Controller is for use on lighting structures or towers 351' to 700' AGL (above ground level) that are approved to be lighted with Dual White/Red Flashing Medium Intensity Strokes in accordance with the FAA Advisory Circular 70/7460-1K.

1.2 SPECIFICATIONS OF EQUIPMENT

Dimensions:

Controller (H x W x D)/Weight	33.00" x 36.75" x 9.0"/210.0 lbs.
Mounting Dim (H x W)	37.375" x 24.0"
Beacon Height/Weight	28.0" /36 lbs.
Cable Diameter/Weight per 100 ft.	625" +/- 10% 24 lbs.

Electrical Voltage:	120V AC +/- 10% 60 Hz (Standard) 240V AC +/- 10% 60 Hz (Available)
---------------------	---

Intensity:	
White Daymode	20,000 +/- 25% Effective Candelas
Red Nightmode	2,000 +/- 25% Effective Candelas
White Nightmode (Back-up mode)	2,000 +/- 25% Effective Candelas

Beam Spread:	
Horizontal	360°
Vertical	3° Minimum

Flash Rate:	
White Daymode	40 fpm +/- 2 fpm
Red Nightmode	22 fpm +/- 2 fpm
White Nightmode (Back-up mode)	40 fpm +/- 2 fpm

Wattage:	
Daymode	285 Watts
Red Nightmode	930 Watts
White Nightmode	105 Watts

Temperature:	+55°C / -55°C
--------------	---------------

Beacon Wind Load:	2.1 ft ²
-------------------	---------------------

TWR Lighting, Inc. HARK[®]

Enlightened Technology[®]

E2/3DB CONTROLLER

2.0 INSTALLATION

WARNING - DANGER!!

THIS SYSTEM OPERATES AT HIGH VOLTAGE LEVELS THAT COULD BE LETHAL TO SERVICE PERSONNEL. ALL INSTALLATION AND MAINTENANCE WORK SHOULD BE DONE BY QUALIFIED SERVICE PERSONNEL ONLY. WHEN PERSONNEL IS INSTALLING SYSTEM OR PERFORMING MAINTENANCE ON THIS SYSTEM, MAKE SURE THE POWER IS TURNED OFF AT THE SERVICE BREAKER PANEL!!

READ AND UNDERSTAND THE THEORY OF OPERATION AND ITS SAFETY MESSAGES BEFORE ATTEMPTING INSTALLATION/MAINTENANCE OF THIS SYSTEM. DO NOT ATTEMPT TO DEFEAT THE INTERNAL SAFETY SWITCHES IN THE CONTROLLER AND BEACONS!!

2.1 POWER SUPPLY CONTROL CABINET MOUNTING

The power supply control cabinet can be located at the base of the structure or in an equipment building. Mounting Dimensions can be found in Section 1.2, on page 5. Pay particular attention when choosing your controller mounting location to ensure proper door opening and room for service personnel. Refer to installation drawings INS-279, and HDO-279, for ease of install.

2.2 PHOTOCELL HOUSING

The standard photocell housing is supplied with a 20' pigtail of 16 AWG TYPE TFFN wire. On occasion, in mounting of the photocell, an additional amount of wire may be required. Refer to drawing 100239, for proper assistance on determining gauge of wire for your specific needs.

E2/3DB CONTROLLER

2.3 PHOTOCELL WIRING

(Refer to Drawings HDO-279, and H40-279)

If the control cabinet is mounted inside an equipment building, the photocell should be mounted vertically on ½" conduit outside the building above the eaves facing north. Wiring from the photocell housing socket to the control cabinet should consist of one (1) each; red, black, and white wires. The white wire is connected to the socket terminal marked "N," the black wire is connected to the socket terminal marked "L," and the red wire is connected to the socket terminal marked "LO." The photocell should be positioned so that it does not "see" ambient light, which would prevent it from switching to the nightmode.

If the control cabinet is mounted outside an equipment building, the photocell should be mounted vertically on ½" conduit so the photocell is above the control cabinet. Care must be taken to assure that the photocell does not "see" any ambient light that would prevent it from switching into the nightmode. The photocell housing socket wiring is the same as above.

2.3.1 Connect the **BLACK** wire from the photocell to terminal block TB2-5.

2.3.2 Connect the **RED** wire from the photocell to terminal block TB2-6.

2.3.3 Connect the **WHITE** wire from the photocell to terminal block TB2-7.

2.3.4 Install the photocell into the receptacle and twist to the right while depressing to lock into place.

2.4 POWER WIRING

(Refer to Drawing H40-279)

Power wiring to the control cabinet should be in accordance with local methods and the National Electric Code (NEC).

2.4.1 A 30 amp circuit breaker is recommended at service panel

2.4.2 Connect the "HOT" side of the 120V AC line to TB1-16.

2.4.3 Connect the "NEUTRAL" side of the 120V AC line to TB1-17.

E2/3DB CONTROLLER

- 2.4.4 Connect the AC ground to the ground lug to the lower right of the terminal block TB1.
- 2.4.5 Controller panel should be connected to the tower and/or building grounding system with the exception of installations on AM/RF Applications where controller grounding to earth ground is prohibited. Ground the controller only to the tower itself using a suitable RF ground.

2.5 TOWER LIGHTING KIT

When installing this system, the customer will need to use strobe cable method to wire the strobe beacons. Refer to Lighting Kit drawings 601-01, for conduit cable, and 601, for cable installations.

WARNING DANGER!!!

THIS SYSTEM OPERATES AT HIGH VOLTAGE LEVELS THAT COULD BE LETHAL TO SERVICE PERSONNEL. ALL INSTALLATION AND MAINTENANCE WORK SHOULD BE DONE BY QUALIFIED SERVICE PERSONNEL ONLY. WHEN PERSONNEL IS INSTALLING SYSTEM OR PERFORMING MAINTENANCE ON THIS SYSTEM, MAKE SURE THE POWER IS TURNED OFF AT THE SERVICE BREAKER PANEL!!

READ AND UNDERSTAND THE THEORY OF OPERATION AND ITS SAFETY MESSAGES BEFORE ATTEMPTING INSTALLATION/ MAINTENANCE OF THIS SYSTEM. DO NOT ATTEMPT TO DEFEAT THE INTERNAL SAFETY SWITCHES IN THE CONTROLLER AND BEACONS!!

- 2.5.1 Beacon Mounting and Wiring
(Refer to Drawings HDO-279, and INS-279)
- 2.5.1.1 Bolt the beacon to the mounting plate using four 5/8" x 1-1/4" galvanized bolts that are supplied. Installer should make sure to check for full thread engagement on Anco locknut. Allow 16" clearance in back of the hinge (25" from the center of the base) to tilt lens back without hitting an obstruction.

E2/3DB CONTROLLER

2.5.1.2 Level the beacon using the spirit level at the base of the lens. Shims may be used under beacon base or triple nutting each bolt with palnuts on all four (4) nuts.

2.5.1.3 Slip the electrical cable for the dual beacon through the watertight connector (cable gland bushing) and tighten the gland nut to make a watertight seal. Attach the wires to the terminal strip as follows:

Wire color	to match	Lamp platform wire color	Terminal Block No.
10 Gauge Black		20 Gauge Black	5
10 Gauge		12 Gauge Red/	3
10 Gauge Red		12 Gauge Red/Black	2
14 Gauge White		20 Gauge White	6
14 Gauge		20 Gauge	7
14 Gauge Green		20 Gauge Green	4
16 Gauge Blue		20 Gauge Blue	8
16 Gauge Brown		20 Gauge Brown	9
16 Gauge Bare		Beacon Base	

2.5.2 LIGHTING KIT WIRING

Install wiring between the controller and the beacon utilizing strobe cable method. Refer to drawings HDO-279, 601, and 601-01, for installation of light kits. Following these minimum guidelines as well as any local or end user addition requirements, installing light kits will require lifting of the cable by the supplied cable grip or conduit to affix to the tower. Always work safely and adhere to all OSHA Safety Guidelines when lifting wiring or working on the structure or tower itself. It is the installer's responsibility to install the lighting kit in a safe manner. Installers can request from OSHA their requirements 29CFT 1926.21, and 29CFR 1926.105 to ensure compliance to regulations.

NOTE: On occasion, a set of custom lighting kit drawings may be specifically requested by a customer and installed in this manual. In cases such as this, the drawings will precede the manual if a conflict occurs.

E2/3DB CONTROLLER

All the necessary information for wiring the dual beacons and sidelights is contained on the tower kit drawings 601, and 601-01. The connections for the dual beacons and sidelights in the controller are as follows:

- 2.5.2.1 Connect the 10 gauge **Red/Black** wire from Beacon #1 wiring to TB1-1.
- 2.5.2.2 Connect the 10 gauge **Red** wire from Beacon #1 wiring to TB1-2.
- 2.5.2.3 Connect the 10 gauge **Black** wire from Beacon #1 wiring to TB1-3.
- 2.5.2.4 Connect the 14 gauge **White** wire from Beacon #1 wiring to TB1-4.
- 2.5.2.5 Connect the 14 gauge **White/Green** wire from Beacon #1 wiring to TB1-5.
- 2.5.2.6 Connect the 10 gauge **Red/Black** wire from Beacon #2 wiring to TB1-6.
- 2.5.2.7 Connect the 10 gauge **Red** wire from Beacon #2 wiring to TB1-7.
- 2.5.2.8 Connect the 10 gauge **Black** wire from Beacon #2 wiring to TB1-8.
- 2.5.2.9 Connect the 14 gauge **White** wire from Beacon #2 wiring to TB1-9.
- 2.5.2.10 Connect the 14 gauge **White/Green** wire from Beacon #2 wiring to TB1-10.
- 2.5.2.11 Connect the 10 gauge **Red/Black** wire from Beacon #3 wiring to TB1-11.
- 2.5.2.12 Connect the 10 gauge **Red** wire from Beacon #3 wiring to TB1-12.

E2/3DB CONTROLLER

- 2.5.2.13 Connect the 10 gauge **Black** wire from Beacon #3 wiring to TB1-13.
- 2.5.2.14 Connect the 14 gauge **White** wire from Beacon #3 wiring to TB1-14.
- 2.5.2.15 Connect the 14 gauge **White/Green** wire from Beacon #3 wiring to TB1-15.
- 2.5.2.16 Connect the 14 gauge **Green** wire from Beacon #1 to the first ground lug located to the left of TB1.
- 2.5.2.17 Connect the 14 gauge **Green** wire from Beacon #3 to the first lug located to the left of TB1.
- 2.5.2.18 Connect the 16 gauge Bare Drain wire (if strobe cable install) from Beacon #1 to second ground lug located to the left of TB1.
- 2.5.2.19 Connect the 16 gauge Bare Drain wire (if strobe cable install) from Beacon #2 to second ground lug located to the left of TB1.
- 2.5.2.20 Connect the 16 gauge Bare Drain wire (if strobe cable install) from Beacon #3 to second ground lug located to the left of TB1.
- 2.5.2.21 Connect the 16 gauge **Brown** wire from Beacon #1 wiring to TB2-1.
- 2.5.2.22 Connect the 16 gauge **Blue** wire from Beacon #1 to TB2-2.
- 2.5.2.23 Connect the 16 gauge **Blue** wire from Beacon #2 to TB2-2.
- 2.5.2.24 Connect the 16 gauge **Brown** wire from Beacon #2 to TB2-3.
- 2.5.2.25 Connect the 16 gauge **Brown** wire from Beacon #3 to TB2-3.
- 2.5.2.26 Connect the 16 gauge **Blue** wire from Beacon #3 to TB2-4.

E2/3DB CONTROLLER

- 2.5.2.27 Connect the **Red** wire from the Sidelight #1 to fuse block marked SL1.
- 2.5.2.28 Connect the **Yellow** wire from the Sidelight #2 to fuse block marked SL2.
- 2.5.2.29 Connect the **White Neutral** wire from Sidelights #1 and #2 to TB1-17.
- 2.5.2.30 Connect the **Green** ground wire (if cable is used) from Sidelights #1, and #2, wiring the ground lug to the lower right of TB1.

2.6 ALARM WIRING

Alarm contacts (Form C) are provided for strobe failures, power failure and photocell on. It is left up to the customer or installer on how they choose to utilize these contacts with their monitoring equipment. External monitoring equipment is available. Please inquire within the sales staff at the factory for models available and pricing. Alarm configurations are shown on drawings H40-279, and M01-279.

2.6.1 White Strobe #1 Failure (ST1)

Connect the customer's alarm common to plug J3, terminal #2. Connect the customer's alarm wire to plug J3, terminal #3, for normally open (or) terminal #1, for normally closed monitoring.

2.6.2 White Strobe #2 Failure (ST2)

Connect the customer's alarm common to plug J3, terminal #5. Connect the customer's alarm wire to plug J3, terminal #6, for normally open (or) terminal #4, for normally closed monitoring.

2.6.3 White Strobe #3 Failure (ST3)

Connect the customer's alarm common to plug J3, terminal #8. Connect the customer's alarm wire to plug J3, terminal #9, for normally open (or) terminal #7, for normally closed monitoring.

E2/3DB CONTROLLER

2.6.4 Red Strobe Failure (RF)

Connect the customer's alarm common to plug J3, terminal #14. Connect the customer's alarm wire to plug J3, terminal #15, for normally open (or) terminal #13, for normally closed monitoring.

NOTE: All three (3) red strobe alarms are grouped due to the fail-safe operation.

2.6.5 Power Failure (PF)

Connect the customer's alarm common to plug J3, to terminal #11. Connect the customer's alarm wire to plug J3, terminal #12, for normally open (or) terminal #10, for normally closed monitoring.

2.6.6 Photocell (PC)

Connect the customer's alarm common to plug J3, terminal #17. Connect the customer's alarm wire to plug J3, terminal #18, for "off" operation (or) terminal #16, for "on" operation monitoring.

2.6.7 Sidelight #1 Alarm (SA1)

Connect the customer's alarm common to Module M1, terminal T4. Connect the customer's alarm wire to Module M1, terminal T5, for normally open (or) terminal T6, for normally closed monitoring.

2.6.8 Sidelight #2 Alarm (SA2)

Connect the customer's alarm common to Module M2, terminal T4. Connect the customer's alarm wire to Module M2, terminal T5, for normally open (or) terminal T6, for normally closed monitoring.

E2/3DB CONTROLLER

2.7 ALARM TESTING

To test alarms, follow these procedures using an "ohm" meter between alarm common and alarm points.

2.7.1 White Strobe Failure (ST1, ST2, and ST3)

White strobe failure testing can be performed in the day mode operation. Check for status of strobe beacons. Turn "off" switch S1 on PCB #1, and status should change after a four (4) second delay. After test, turn S1 to the normal operating position.

2.7.2 Red Strobe Failure (RF)

Red strobe failure testing can be performed in the night mode operation. Check for status of strobe beacons. Turn "on" switch SW2 on controller panel and status should change after an eight (8) second delay. This testing will cause the unit to go into the back-up white strobe operation. To clear this situation, turn off SW2 and reset the breaker.

2.7.3 Power Failure (PF)

While the controller is in normal operation, shut off power to the controller at the breaker panel. Alarm should be prompt. Reset the breaker to resume normal operation.

2.7.4 Photocell (PC)

Controller should be in the daymode of operation when performing this test. Check status of operation. Turn SW1 on (or) cover the photocell and operation status should change state. After test, turn SW1 to normal operating position.

2.7.5 Sidelight #1 Alarm (SA1)

Controller should be in the nightmode of operation. Check status of operation. Pull fuse switch SL1 open. Alarm should occur within five (5) seconds. After test, re-engage fuse switch SL1.

E2/3DB CONTROLLER

2.7.6 Sidelight #2 Alarm (SA2)

Controller should be in the nightmode of operation. Check status of operation. Pull fuse switch SL2 open. Alarm should occur within five (5) seconds. After test, re-engage fuse switch SL2.

2.8 CONTROLLER CONFIGURATION

(Refer to Drawing H01-279)

This unit is factory setup to be a master controller. If this unit is to be used in conjunction with an additional unit, change dip switch settings as drawing indicates. The following connections will need to be interfaced between systems.

- 2.8.1 Connect at least an 18/20 gauge wire from PCB #1, connector P1-15, from unit set-up to be the master unit to PCB #1, connector P1-15, of unit set-up to be the slave unit.
- 2.8.2 Connect at least an 18/20 gauge wire from TB1-9 of master unit to slave unit TB2-6.
- 2.8.3 Connect at least an 18/20 gauge wire (ground) from one (1) chassis to the other chassis.
- 2.8.4 Use a single breaker for supply power to all controllers.
- 2.8.5 Follow standard instructions provided in the manuals supplied with the controllers.

E2/3DB CONTROLLER

3.0 THEORY OF OPERATION

3.1 THE POWER SUPPLY

The AC line is sent to transformers T2, and T2A through fuses F2, F3, MOVMOD, and relay K1. In order for K1 to energize and complete the circuit to T2 and T2A, the safety interlock switch CSS, BSS, must be closed. The BSS switch is located in the base of the beacon. In order for the system to operate, the beacons and the power supply must be closed and secured.

Transformers T2, and T2A secondary outputs are around 1,000V AC. These outputs are sent to the high voltage rectifier PCB (PCB #2) and converts the 1,000V AC of each transformer to around +550V DC and -550V DC in daymode and +700V DC and -550V DC in nightmode. This high voltage is then used to charge the energy storage capacitors C102, C112, and C122 through current limiting resistors R31A, R31B, and R31C, and steering diodes D5, D6, and D8, for nightmode operation. Resistors R31A, R31B, and R31C are bypassed through K5A, K5, and K5C for daymode operation.

Energy storage capacitors bank C103-131 is used for the daymode operation and are connected to the high voltage through the normally closed contacts of relays K5A, K5B, and K5C. When the light level drops below 3 foot candles, the photocell supplies 120V AC to relays K5A, K5B, and K5C, which removes C103-131 from the discharge path leaving capacitors C102, C112, and C122 in the circuit for nightmode operation. The energy storage capacitor banks are connected to the flashtube through the interconnecting tower wiring.

3.2 THE FLASHTUBE

The flashtubes FTW1, FTW2, and FTW3 (daymode) and FTR1, FTR2, and FTR3 (nightmode) are quartz tubes containing two (2) electrodes each. The electrode at the positive (+) end is called the anode and is connected to the positive side of the storage capacitors through inductors L1, L11, L2, L22, L3, and L33. The electrode at the negative (-) end of the tube is called the Cathode and is connected to the negative side of the energy storage capacitors banks.

E2/3DB CONTROLLER

The flashtube contains a gas called Xenon. When the high voltage energy in the storage capacitors is connected to the flashtube, nothing will happen since Xenon in its natural state is not a conductor of electricity. However, when a very short duration high voltage pulse is impressed on the trigger element of the tube (via the power supply and trigger transformers T4, T5, T6, T7, T8, and T9) the Xenon gas is ionized and thereby becomes a good conductor of electricity. This allows the electrical energy in the storage capacitors to discharge rapidly through the flashtube, which converts this energy to light energy and heat energy. When the voltage stored in the capacitors discharges to a low level, the Xenon gas can no longer sustain conduction and since the short trigger pulse is gone by this time, it de-ionizes returning to its non-conducting state until another trigger pulse arrives to repeat the process. Meanwhile, the storage capacitor is being re-charged by the transformer and the high voltage rectifiers.

3.3 TIMING CIRCUIT

The timing circuit is contained entirely on printed circuit board #1. The timing circuit has its own power supply. This circuit converts the AC voltage to approximately 12V DC, which is used to supply all of the components in this circuit. It uses this low voltage DC to generate pulses that control the flash rate of the flashtube. It actually generates two (2) groups of pulses. The first is a pulse approximately once every 1.2 seconds to operate the flashtube during daylight hours. The second is a burst at 100Hz to elongate the apparent flash during the night time hours at reduced flash energy.

3.4 TRIGGER CIRCUIT

The trigger circuit is supplied by transformer T1 secondary windings. The 250V AC is converted to DC, which is stored in a storage capacitor much like the action of the high voltage circuit. The main difference is that the storage capacitor is much smaller. The trigger circuit receives the pulses generated by the timing circuit. It releases its stored energy with each pulse and delivers it to the flashtube's trigger element to initiate each flash.

E2/3DB CONTROLLER

3.5 ALARM CIRCUITS

3.5.1 White Strobe Failure (ST1, ST2, and ST3)

White Strobe Failure alarm circuit monitors each flash of the day mode flashtube within the beacon. If the flashtube fails to flash (for any reason) the alarm circuit operates relays K7A, K7B, and K7C (on PCB #3) that the customer can connect to their alarm transmitting devices. The alarm point can be accessed on J3, of PCB #3.

3.5.2 Red Strobe Failure (RF)

Red Strobe Failure alarm circuit monitors each flash of the night mode flashtube within each beacon. If any Red Strobe flashtube fails to flash (for any reason) the alarm circuit would operate relay K8 (on PCB #3) that the customer can connect to their alarm transmitting devices. The alarm point can be accessed on J3, of PCB #3.

3.5.3 Power Failure (PF)

The power failure alarm relay is energized during normal operation. Should the power be removed for any reason, then relay K1A would drop, creating an alarm for the customer alarm transmitting device.

3.5.4 Photocell (PC)

The photocell alarm relay K4 is energized whenever the photocell or SW3 is on. This relay will allow the customer to monitor the modes of operation to determine if switch from day to night mode has occurred.

3.5.5 Sidelight Alarm (SA1, and SA2)

Modules M1, and M2 monitor the current flowing to the sidelights. These modules can monitor from (1-4) 116W lamps. Factory setting is generally for three (3) lamps. When the current falls below two (2) amps (one [1] lamp less than the factory setting), then the onboard relay will engage, creating an alarm.

E2/3DB CONTROLLER

3.6 BLEEDER CIRCUIT

The bleeder circuit is the most important safety item in this system. It consists of resistors R32A, R32B, and R32C connected to the high voltage storage capacitor through relays K2, and K2A. When the AC line voltage is turned off, the relay will close allowing the resistors to discharge the high voltage stored in the capacitor banks below 50V in 30 seconds.

**** CAUTION ****

NEVER RELY ON THIS CIRCUIT TO RENDER THIS SYSTEM HARMLESS. ANY DEFECT IN THIS CIRCUIT COULD ALLOW A HAZARDOUS HIGH VOLTAGE CHARGE TO REMAIN ON THE STORAGE CAPACITORS. ALWAYS WAIT AT LEAST 30 SECONDS AFTER POWER HAS BEEN TURNED OFF BEFORE STARTING ANY WORK ON THIS SYSTEM. ALWAYS MEASURE THE VOLTAGE ON THE STORAGE CAPACITORS WITH A VOLTMETER BEFORE STARTING ANY OTHER WORK ON THIS SYSTEM. NEVER ATTEMPT TO DEFEAT THE SAFETY INTERLOCKS.

3.7 STROBE DIAGNOSTIC CIRCUITS

The diagnostic circuit is provided as a means of making system checks and maintenance more convenient. This circuit is entirely contained on the printed circuit boards PCB #1, and PCB #2. The circuits that are contained on PCB #1, and PCB #2 are as follows:

3.7.1 Control Power On

Line from the 120V AC input is sent through safety switches CSS, BSS, isolation transformer T1, and fuse F11, on PCB #1. Once this low voltage is at PCB #1, it is rectified, and then sent to LED4 (D5). If for any reason power is interrupted, (beacons opened, controller door open, blown F1 fuse, failed relay, etc.) LED4 would be extinguished.

E2/3DB CONTROLLER

3.7.2 High Voltage

The Cathode side of the high voltage HV1, HV2, and HV3, are routed through current limiting resistors (R201, R202, and R203). When the unit is in daymode, D14, D15, and D16 will be at full brightness when the capacitors are at full charge but, dims with the discharging of the storage capacitors. A constant intensity indicates that high voltage is present but capacitors are not discharging (check other indicators for fault). When the red LEDs fail to glow, then the high voltage is no longer present.

3.7.3 Trigger Voltage

The trigger voltage from fuse F41 (PCB #4) is sent to current limiting resistor R1, and LED6 (D11). Under normal circumstances, the red LED should be at full intensity, indicating voltage to be normal. An absence of this indication means that the voltage is no longer present.

3.7.4 Nightmode

Output voltage from the photocell (SSR) is connected to the coil of relay K4 on PCB #3. Whenever the photocell senses the darkness, or switch SW1 is on, relay K4 will energize, thereby sending 120V to relay U2. Relay U2 will supply 12V DC to the timing circuit as well as LED7 (D7). LED7 will glow a constant red when in the nightmode.

3.7.5 Primary Timing

The primary timing pulses are received at LED8 (D12). LED8 will flash according to the pulses received from the timing circuit. If LED8 fails to flash, then the primary timing circuit has failed. Check LED9 (D28) for secondary timing operation. The strobe unit should produce 40 (+/- 2) pulses per minute in daymode or nightmode back-up operation. The strobe unit in nightmode operation should produce 22 (+/- 2) pulses per minute.

3.7.6 Timing Signal Verify

Timing pulses (either primary or secondary) are received at LED9 (D28). The LED will flash according to the pulses received from the timing circuit. In the unlikely event that this LED is out, then total timing failure has occurred.

E2/3DB CONTROLLER

3.7.7 Flash Verified

Current from the Cathode side of the flashtube (FTC1, FTC2, and FTC3) are sent through the current sensing transformers T1, T2, T3, T4, T5, and T6 on PCB #1. T1, T2, T3, T4, T5, and T6 will send a pulse to the gate of the SCR's Q6, Q8, Q10, Q13, Q14, and Q17, and turns it on. Capacitors C12, C13, C14, C15, C16, and C17, via Q6, Q8, Q10, Q13, Q13, Q14, and Q17, will send voltage to LED1 (D20), LED3 (D21), and LED5 (D22). After each confirmed flash, LED1 and LED3 will blink. Absence of a blinking LED signifies that strobe beacon has ceased to flash.

3.7.8 Strobe Fail Test

Switch S1, when turned on, cuts off timing signal to the trigger circuit and extinguishes LED8 (D12). At this time the strobe alarm should be received at J3. The normal position of S1 is off (switch downward).

E2/3DB CONTROLLER

4.0 TROUBLESHOOTING

Much of the troubleshooting of this system will consist of correcting a "beacon out" situation. There may also be a failure mode where flashtube is still flashing, but at the wrong rate or the wrong intensity.

You must study and understand the safety messages and the theory of operation before attempting any service on this system. Servicing this system must be done by qualified personnel only.

4.1 TOOL REQUIREMENTS

In order to be prepared to trouble shoot or repair this system, a minimum amount of tools and equipment will be required. A recommendation list includes:

- 1) 5/16 Flat Electrician's Screwdriver
- 1) #2 Phillips Screwdriver
- 1) Nut Driver or Socket Set
- 1) Multi meter - Analog or Digital 600V AC / 600V DC Minimum

4.2 DIAGNOSTIC EVALUATION

The first step in trouble shooting of this system or performing annual maintenance will require the technician to open the controller door. With the power off to the controller, the technician should look over the controller circuit and repair or replace any apparent problems such as loose wire connections or corroded terminations. After the initial visual checks have been completed, restore power to the controller and pull out on the plunger of the cabinet safety switch (CSS) located at the lower right edge of the enclosure. Observe at this time the LEDs located on PCB #1 and PCB #2. Determine, by observation of these LED indicators, if the controller is performing to normal operation.

LEDs on PCB #1 are numbered from top to bottom, 1-9. LEDs on PCB #2 are numbered from top to bottom D14 - D16. (See drawings H40-279, and H01-279.)

E2/3DB CONTROLLER

4.3 TROUBLESHOOTING ASSISTANCE

4.3.1 Flash Verify LED - Out

4.3.1.1 Observe high voltage LED (D14, D15, and D16) on the same beacon circuit to determine if it is available. If the LED is dim or out completely, then check the high voltage capacitor bank (C103 - C131 day, C102, C112, and C122 night) for a short. If no capacitor is found to be shorted, check the resonant capacitor (C101, and C101A) for a short. If the resonant capacitor is okay, replace PCB #2. If the LED is at full illumination, go to the next step.

4.3.1.2 Check the status of trigger LED6. If LED is dim or off, check fuse F41. If blown, replace with exact type of fuse. If the fuse blows again, check transformer T1. Replace as necessary. If LED is okay, go to the next step.

4.3.1.3 If steps 4.3.1.1 and 4.3.1.2 check out okay, re-lamp the beacon.

4.3.2 Control Power on LED - Out

Check interlock circuits for an open circuit. If open, make the necessary repairs. If okay, check fuses F2, and F3. Replace if bad.

4.3.3 Primary Timing LED - Out

Observe the status of the timing LED8. If the LED is dim or out completely, check LED9, if dim or out, replace PCB #1. If one or both are lit, you should have timing.

4.3.4 False or Nonexistent Beacon Alarms (ST1, ST2, and ST3)

4.3.4.1 If alarm trips when the system appears to be working normally or fails to show an alarm when there is an obvious failure, check PCB #1 P1-4, and P1-10 for 120V AC output. If voltage is okay, go to the next step.

4.3.4.2 Check relays K7A, K7B, and K7C coils for an open condition. Normal resistance should be around 2K ohm. If one (1) or more coils are open, replace relay.

E2/3DB CONTROLLER

4.3.4.3 The time delay between an actual failure and the point where the relay trips is pre-set at the factory or about eight (8) seconds. This delay period can be tested by throwing "on" (*upward*) switch number S1 (on the circuit board #1). After testing return switch S1 to its normal (*downward*) position.

4.3.5 False or Nonexistent Beacon Alarm (RF)

If alarm trips when the system appears to be working normally or fails to show an alarm when there is an obvious failure, check relay K8 coil for an open condition. Normal resistance should be around 2K ohm. If coil is open, replace K8.

4.3.6 No Red Strobe Operation

4.3.6.1 Check if switch SW2 is on. If switch is off, turn switch to the on position (*upward*). Reset the circuit breaker at the service panel. If okay, go to the next step.

4.3.6.2 Turn switch SW1 to the upward position. On the breaker at the service panel to the lights, turn off, then back on. If the beacons comes on, then the unit fail-safes back to the white back-up mode of operation, then replace the failed red mode flashtube.

Note: Once the unit fail-safes, you will need to reset the breaker at the panel in order to release the latched relay in this circuit anytime a failure has been detected. This is an important fact to remember when troubleshooting this system.

E2/3DB CONTROLLER

5.0 MAINTENANCE GUIDE

****WARNING - HIGH - VOLTAGE****

THIS SYSTEM OPERATES AT HIGH VOLTAGE LEVELS THAT COULD BE LETHAL TO SERVICE PERSONNEL. ALL INSTALLATION AND MAINTENANCE WORK SHOULD BE DONE BY QUALIFIED SERVICE PERSONNEL. READ AND UNDERSTAND THE THEORY OF OPERATION AND ITS SAFETY MESSAGES BEFORE ATTEMPTING; INSTALLATION OF THIS SYSTEM. DO NOT ATTEMPT TO DEFEAT THE INTERNAL SAFETY DEVICES.

Tools Required: #2 Phillips Screwdriver
 3/16 Flat Blade Screwdriver

5.1 FLASHTUBE REPLACEMENT

The only required maintenance needed to be performed is the replacement of the flashtubes every four (4) years. By following these instructions, maximum safety and performance can be achieved.

5.1.1 Loosen the single quick open bolt located on upper hinge assembly.

5.1.2 Open the lens and tilt it back.

ALWAYS WAIT AT LEAST 30 SECONDS AFTER OPENING THE BEACON BEFORE STARTING ANY WORK ON THE BEACON.

5.1.3 Loosen the three (3) socket screws with a #2 Phillips screwdriver to remove lamp.

5.1.4 Install the new nightmode flashtube making sure that the pins are aligned with the socket. Make sure tube is flush on the socket.

5.1.5 Tighten the socket screws snug, then 1/4 turn more.

5.1.6 Open the internal hatch plate latch and let it recline open.

5.1.7 Disconnect the cable running through the tube from the 10 position terminal block located at the base of the fixture.

5.1.8 Loosen the three (3) socket screws with a #2 Phillips screwdriver.

E2/3DB CONTROLLER

- 5.1.9 To remove the flashtube, slide the lamp down to the cable.
- 5.1.10 To install a flashtube, slide the lamp over the connector on to the cable with the lamp in the base up position.
- 5.1.11 Insert the flashtube with the pins aligned with the socket.
- 5.1.12 Tighten the socket screws snug, then 1/4 turn more.
- 5.1.13 Reconnect cable connection. Make sure to follow the color codes on the cable to the terminal block.
- 5.1.14 Close the hatch and latch securely.
- 5.1.15 Close the upper hinge assembly and latch securely.

5.2 RED OBSTRUCTION LIGHTING

The only required maintenance needed to be performed is replacement of the lamps in the L-810 fixture. Lamps should be replaced after being operated for not more than 75% of the rated life or immediately upon failure as per FAA Advisory Circular 70/7460-1K. By following these instructions, maximum safety and performance can be achieved.

Tools Required: None

5.2.1 LAMP REPLACEMENT

- 5.2.1.1 Unclasp the two (2) latches and let the bail recline back.
- 5.2.1.2 Lift the lens up and over the lamp letting the lens hang from the safety cable.
- 5.2.1.3 Unscrew the lamp counter-clockwise and remove.
- 5.2.1.4 Install the new lamp by screwing the lamp clockwise.
- 5.2.1.5 Re-install the lens making sure it is seated properly on the base.
- 5.2.1.6 Re-clasp the two (2) latches.

E2/3DB CONTROLLER

5.3 POWER SUPPLY

The only required maintenance to be performed is periodic inspection/cleaning of the vent filter. Monthly inspections should be made at first to familiarize yourself with power supply's particular maintenance requirements. Maintenance intervals can vary due to location, seasonal weather conditions, and general housekeeping of site.

The filter is located on the inside of the enclosure on the lower right hand side.

Tools Required: None.

5.3.1 Turn off power at breaker panel.

5.3.2 Open the controller door.

5.3.3 Disconnect P1 and P2 connectors from PCB #1.

5.3.4 Remove PCB #1 from track.

5.3.5 Slide filter up and remove from bracket.

5.3.6 Wash filter with water and squeeze until all excess water is removed. If no water is available, then knock out dust from filter before reinstalling.

5.3.7 Reinstall filter into bracket.

5.3.8 Reinstall PCB #1.

5.3.9 Reconnect P1 and P2 connectors to PCB #1.

5.3.10 Close the controller door.

5.3.11 Turn on power at breaker panel.

5.4 PHOTOCELL

The photocell is a sealed unit. No maintenance is needed or required other than replacement as necessary.

TWR Lighting, Inc. HARK®

Enlightened Technology®

E2/3DB CONTROLLER

6.0 MAJOR COMPONENTS LIST

SCHEMATIC TAG #	PART NUMBER	DESCRIPTION
BSS1, BSS2, BSS3	STJ02003	BEACON SAFETY SWITCH
C101	STB99005	4uf 660V AC CAP
C101A	STB99001	5uf 660V AC CAP
C102, C112, C122	STB99010	4uf 2.5 KV CAP CSI
C103 - C131	STB99006	40uf 1KV CAP
CSS	STJ02001	CABINET SAFETY SWITCH
FAN	EP123815HBT	AXIAL FAN
F1	KTK1	1 amp FUSE
F2	FNQ10	10 amp FUSE
F3	KTK20	20 amp FUSE
F11	FUSE.5	½ amp FUSE
F41	FUSE.125	1/8 amp FUSE
FTW1, FTW2, FTW3	STFLSHTB6	DAYMODE FLASHTUBE
FTR1, FTR2, FTR3	STFLSHTB7	NIGHTMODE FLASHTUBE
K2	STJ10006	HV BLEEDER RELAY DPDT
K2A	PM17AY	HV BLEEDER RELAY 4PDT
K5A, K5B, K5C, K1, K4, K6, K8	KRPA11AG120	DPDT OCTAL RELAY
K7A, K7B, K7C, K1A	KRPA5AG120V	SPDT OCTAL RELAY

E2/3DB CONTROLLER

6.0 MAJOR COMPONENTS LIST (continued)

SCHEMATIC TAG #	PART NUMBER	DESCRIPTION
K9	SPEC224	TIME DELAY RELAY
L1, L2, L3	INDCTR3001	INDUCTOR
L11, L22, L33	100453	INDUCTOR
M1, M2	CM-250 (This replaces the SCR430T modules)	CURRENT SENSORS
MOV2	MOV524V15	METAL OXIDE VARISTOR
MOVMOD	DTK-120HW	SURGE SUPPRESSOR
MOV 3, 4, 5, 6, 7, 8	V1000LA80A	METAL OXIDE VARISTOR
MOV 9, 10, 11, 12, 13, 14	V275LA20A	METAL OXIDE VARISTOR
P1, J1	STT60021	15 POSITION PLUG
P2	STT60019	12 POSITION PLUG
PCB #1	STH01279	E2/3DB CONTROL PCB
PCB #2	STH02258A	HIGH VOLTAGE RECTIFIER PCB
PCB #3	STH03279A	RELAY PCB w/ALARM LOCKOUT ELIMINATION MODIFICATION
PCB #4	STH04269	TRIGGER VOLTAGE RECTIFIER PCB
PHOTOCELL	6390-FAA2 (This replaces the P2455L Photocell)	120 - 240V AC PHOTOCELL

TWR Lighting, Inc. **PARK**

Enlightened Technology

E2/3DB CONTROLLER

6.0 MAJOR COMPONENTS LIST (continued)

SCHEMATIC TAG #	PART NUMBER	DESCRIPTION
R31A, R31B, R31C	STA22004	50 ohm 225W
R32A, R32B, R32C	STA08020	25K ohm 20W
R33A, R33B, R33C	ST08010	2.4 MEG 2W
SL1, SL2	KTK5	5 amp FUSE
SW2	STJ01002	SPST 15 amp SWITCH
SW1	STJ01004	SPDT 15 amp SWITCH
T2	STC30019	FERRORESONANT TRANSFORMER
T2A	STC30020	FERRORESONANT TRANSFORMER
T1	100272	ISOLATION TRANSFORMER
T3A, T3B, T3C	100273	BURSTING CHOKE
T4, T5, T6, T7, T8, T9	STC05005	TRIGGER TRANSFORMER
TB1	TERMBLK-17	17 PART TERM BLK
TB2	TERMBLK141-7	7 PARK TERM BLK
TB3	TERMBLK 141-12	12 PART TERM BLK
TB5	CURBLK	3 PART TERM BLK
TLS1	STJ10008	THERMAL LIMITING SWITCH/210
TLS2	STJ10010	THERMAL LIMITING SWITCH/130

E2/3DB CONTROLLER

6.0 MAJOR COMPONENTS LIST (continued)

SCHEMATIC TAG #	PART NUMBER	DESCRIPTION
TB4	TERMBLK141-4	4 PART TERM BLK
J2	STT60017	6 POSITION PLUG
J3	STT60015	18 POSITION PLUG
	100319	FLASHTUBE SOCKET
	STBEAGSKT	HINGE GASKET
	STBEAGSKT2	LENS GASKET
	STDBCLENS	CLEAR DUAL BEACON LENS
	STDBEAON	DB STROBE BEACON FIXTURE
	STROBCABLE-3	STROBE BEACON CABLE
	STCABLEOB	SIDELIGHT CABLE
	CD045-36	FAN PLUG
	STFILTER	VENT FILTER
	STDBRENS	RED DUAL BEACON LENS
	STCABLTIE	STROBE CABLE TIE
	STDBHATPLT	STDBEAON HATCH PLATE ASSEMBLY
	DBTERMBLK8KIT	DUAL BEACON UPPER TERMINAL BLOCK KIT
	DBTERMBLK10KIT	DUAL BEACON LOWER TERMINAL BLOCK KIT
	CABLEGRIP1	SINGLE EYE LACE MESH .50 - .62

TWR Lighting, Inc. HARK[®]

Enlightened Technology[®]

E2/3DB CONTROLLER

6.0 MAJOR COMPONENTS LIST (continued)

SCHEMATIC TAG #	PART NUMBER	DESCRIPTION
	CABLEGRIP3	SINGLE EYE LACE MESH .63 - .74
	116A21TS	116 W, 120V SIDELIGHT BULB

TWR Lighting, Inc. HARK[®]

Enlightened Technology[®]

E2/3DB CONTROLLER

7.0 SUGGESTED SPARE PARTS LIST

QTY	PART NUMBER	DESCRIPTION
2	KTK1	1 amp FUSE
2	FNQ10	10 amp FUSE
2	KTK20	20 amp FUSE
2	FUSE.5	1/2 amp FUSE
2	FUSE.125	1/8 amp FUSE
1	STH01279	E2/3DB PCB #1
1	6390-FAA2 (This replaces the P2455L Photocell)	120 - 240V AC PHOTOCCELL
1	STJ10006	HV Relay
2	STFLSHTB6	Daymode Flashtube
2	STFLSHTB7	Nightmode Flashtube
1	KRPA11AG120V	DPDT Octal Relay
1	DTK-120HW	Surge Suppressor
1	KRPA5AG120V	SPDT Octal Relay
2	STB99006	40 uf 1.1 kV Cap
1	CM-250 (This replaces the SCR430T modules)	Current Sensor
1	STJ02003	Beacon Safety Switch
1	STJ02001	Cabinet Safety Switch

TWR Lighting, Inc. **MARK**

Enlightened Technology

E2/3DB CONTROLLER

Warranty & Return Policy

TWR Lighting, Inc. (“TWR”) warrants its products (other than “LED Product”) against defects in design, material (excluding incandescent bulbs) and workmanship for a period ending on the earlier of two (2) years from the date of shipment or one (1) year from the date of installation.

TWR Lighting, Inc. (“TWR”) warrants its “LED Product” against defects in design, material and workmanship for a period of five (5) years from the date of shipment. TWR, at its sole option, will, itself, or through others, repair, replace or refund the purchase price paid for “LED Product” that TWR verifies as being inoperable due to original design, material, or workmanship. All warranty replacement “LED Product” is warranted only for the remainder of the original warranty of the “LED Product” replaced. Replacement “LED Product” will be equivalent in function, but not necessarily identical, to the replaced “LED Product.”

TWR Lighting, Inc. (“TWR”) warrants its “LED Product” against light degradation for a period of five (5) years from the date of installation. TWR, at its sole option, will, itself, or through others, repair, replace, or refund the purchase price paid for “LED Product” that TWR verifies as failing to meet 75% of the minimum intensity requirements as defined in the FAA Advisory Circular 150/5345-43G dated 09/26/12. All warranty replacement “LED Product” is warranted only for the remainder of the original warranty of the “LED Product” replaced. Replacement “LED Product” will be equivalent in function, but not necessarily identical, to the replaced “LED Product.”

Replacement parts (other than “LED Product”) are warranted for 90 days from the date of shipment.

Conditions not covered by this Warranty, or which might void this Warranty are as follows:

- x Improper Installation or Operation
- x Misuse
- x Abuse
- x Unauthorized or Improper Repair or Alteration
- x Accident or Negligence in Use, Storage, Transportation, or Handling
- x Any Acts of God or Nature
- x **Non-OEM Parts**

The use of Non-OEM parts or modifications to original equipment design will void the manufacturer warranty and could invalidate the assurance of complying with FAA requirements as published in Advisory Circular 150/5345-43.

TWR Lighting, Inc. HARK®

Enlightened Technology®

E2/3DB CONTROLLER

Warranty & Return Policy (continued)

Field Service – Repairs are warranted for 90 days from the date of service, except where TWR® has made recommendations that were not adhered to that may cause premature failure on previous repairs. Labor, Travel, and Tower Climb are not covered under warranty. Customer shall be obligated to pay for all incurred charges not related to warranty. All warranty repairs are performed by trained TWR® personnel, or dispatched through an extensive network of certified and insured Service Representatives.

Return Terms – You must first contact our Customer Service Department at **713-973-6905** to acquire a Return Merchandise Authorization (RMA) number in order to return the product(s). Please have the following information available when requesting an RMA number:

- x The contact name and phone number of the tower owner
- x The contact name and phone number of the contractor
- x The site name and number
- x The part number(s)
- x The serial number(s) (if any)
- x A description of the problem
- x The billing information
- x The Ship To address

This RMA number must be clearly visible on the outside of the box. If the RMA number is not clearly labeled on the outside of the box, your shipment will be refused. Please ensure the material you are returning is packaged carefully. **The warranty is null and void if the product(s) are damaged in the return shipment.**

All RMAs must be received by TWR LIGHTING®, INC., 4300 WINDFERN RD #100, HOUSTON TX 77041-8943, within 30 days of issuance.

Upon full compliance with the Return Terms, TWR® will replace, repair and return, or credit product(s) returned by the customer. It is TWR®'s sole discretion to determine the disposition of the returned item(s).

TWR Lighting, Inc. **HARK**[®]

Enlightened Technology[®]

E2/3DB CONTROLLER

Warranty & Return Policy (continued)

Replacements – Replacement part(s) will be shipped and billed to the customer for product(s) considered as Warranty, pending return of defective product(s). When available, a certified reconditioned part is shipped as warranty replacement with a Return Merchandise Authorization (RMA) number attached. Upon receipt of returned product(s), inspection, testing, and evaluation will be performed to determine the cause of defect. The customer is then notified of the determination of the testing.

- x Product(s) that is deemed defective and/or unrepairable and covered under warranty - a credit will be issued to the customer's account.
- x Product(s) found to have no defect will be subject to a **\$60.00 per hour testing charge (1 hour minimum), which will be invoiced to the customer.** At this time the customer may decide to have the tested part(s) returned and is responsible for the return charges.
- x Product(s) under warranty, which the customer does not wish returned, the customer will be issued a credit against the replacement invoice.

Repair & Return – A Return Merchandise Authorization (RMA) will be issued for all part(s) returned to TWR[®] for repair. Upon receipt of returned product(s), inspection, testing, and evaluation will be performed to determine the cause of defect. The customer is then notified of the determination of the testing. If the returned part(s) is deemed unrepairable, or the returned part(s) is found to have no defect, the customer will be subject to a **\$60.00 per hour testing charge (1 hour minimum), which will be invoiced to the customer.** Should the returned parts be determined to be repairable, a written estimated cost of repair will be sent to the customer for their written approval prior to any work being performed. In order to have the tested part(s) repaired and/or returned, the customer must issue a purchase order and is responsible for the return shipping charges.

Return to Stock – Any order that is returned to TWR[®] for part(s) ordered incorrectly by the customer, or unneeded upon receipt, the customer is required to pay a **20% restocking fee.** A credit will be issued once it is determined that the Return Terms are met.

Credits – Credits are issued once it is determined that all of the Warranty and Return Terms are met. All credits are processed on Fridays. In the event a Friday falls on a Holiday, the credit will be issued on the following Friday.

Freight – All warranty replacement part(s) will be shipped via ground delivery and paid for by TWR[®]. Delivery other than ground is the responsibility of the customer.

TWR Lighting, Inc. **MARK**

Enlightened Technology

E2/3DB CONTROLLER

Warranty & Return Policy

(continued)

REMEDIES UNDER THIS WARRANTY ARE LIMITED TO PROVISIONS OF REPLACEMENT PARTS AND REPAIRS AS SPECIFICALLY PROVIDED. IN NO EVENT SHALL TWR® BE LIABLE FOR ANY OTHER LOSSES, DAMAGES, COSTS, OR EXPENSES INCURRED BY THE CUSTOMER, INCLUDING, BUT NOT LIMITED TO, LOSS FROM FAILURE OF THE PRODUCT(S) TO OPERATE FOR ANY TIME, AND ALL OTHER DIRECT, INDIRECT, SPECIAL, INCIDENTAL, OR CONSEQUENTIAL DAMAGES, INCLUDING ALL PERSONAL INJURY OR PROPERTY DAMAGE DUE TO ALLEGED NEGLIGENCE, OR ANY OTHER LEGAL THEORY WHATSOEVER. THIS WARRANTY IS MADE BY TWR® EXPRESSLY IN LIEU OF ALL OTHER WARRANTIES, WHETHER EXPRESSED OR IMPLIED. WITHOUT LIMITING THE GENERALITY OF THE FORGOING, TWR® MAKES NO WARRANTY OF MERCHANTABILITY OR FITNESS OF THE PRODUCT(S) FOR ANY PARTICULAR PURPOSE. TWR® EXPRESSLY DISCLAIMS ALL OTHER WARRANTIES.

TWR Lighting, Inc. HARK[®]

Enlightened Technology[®]

E2/3DB CONTROLLER

RETURN MERCHANDISE AUTHORIZATION (RMA) FORM

RMA#: _____ **DATE:** _____

CUSTOMER: _____

CONTACT: _____ **PHONE NO.:** _____

ITEM DESCRIPTION (PART NO.): _____

MODEL NO.: _____ **SERIAL NO.:** _____

ORIGINAL TWR INVOICE NO.: _____ **DATED:** _____

DESCRIPTION OF PROBLEM: _____

SIGNED: _____ **DATE NEEDED:** _____

RETURN ADDRESS: _____

PLEASE RETURN PRODUCT TO: 4300 WINDFERN RD #100 HOUSTON TX 77041-8943

TWR Lighting, Inc. HARK[®]

Enlightened Technology[®]

E2/3DB CONTROLLER

RETURN MERCHANDISE AUTHORIZATION (RMA) FORM

RMA#: _____ **DATE:** _____

CUSTOMER: _____

CONTACT: _____ **PHONE NO.:** _____

ITEM DESCRIPTION (PART NO.): _____

MODEL NO.: _____ **SERIAL NO.:** _____

ORIGINAL TWR INVOICE NO.: _____ **DATED:** _____

DESCRIPTION OF PROBLEM: _____

SIGNED: _____ **DATE NEEDED:** _____

RETURN ADDRESS: _____

PLEASE RETURN PRODUCT TO: 4300 WINDFERN RD #100 HOUSTON TX 77041-8943

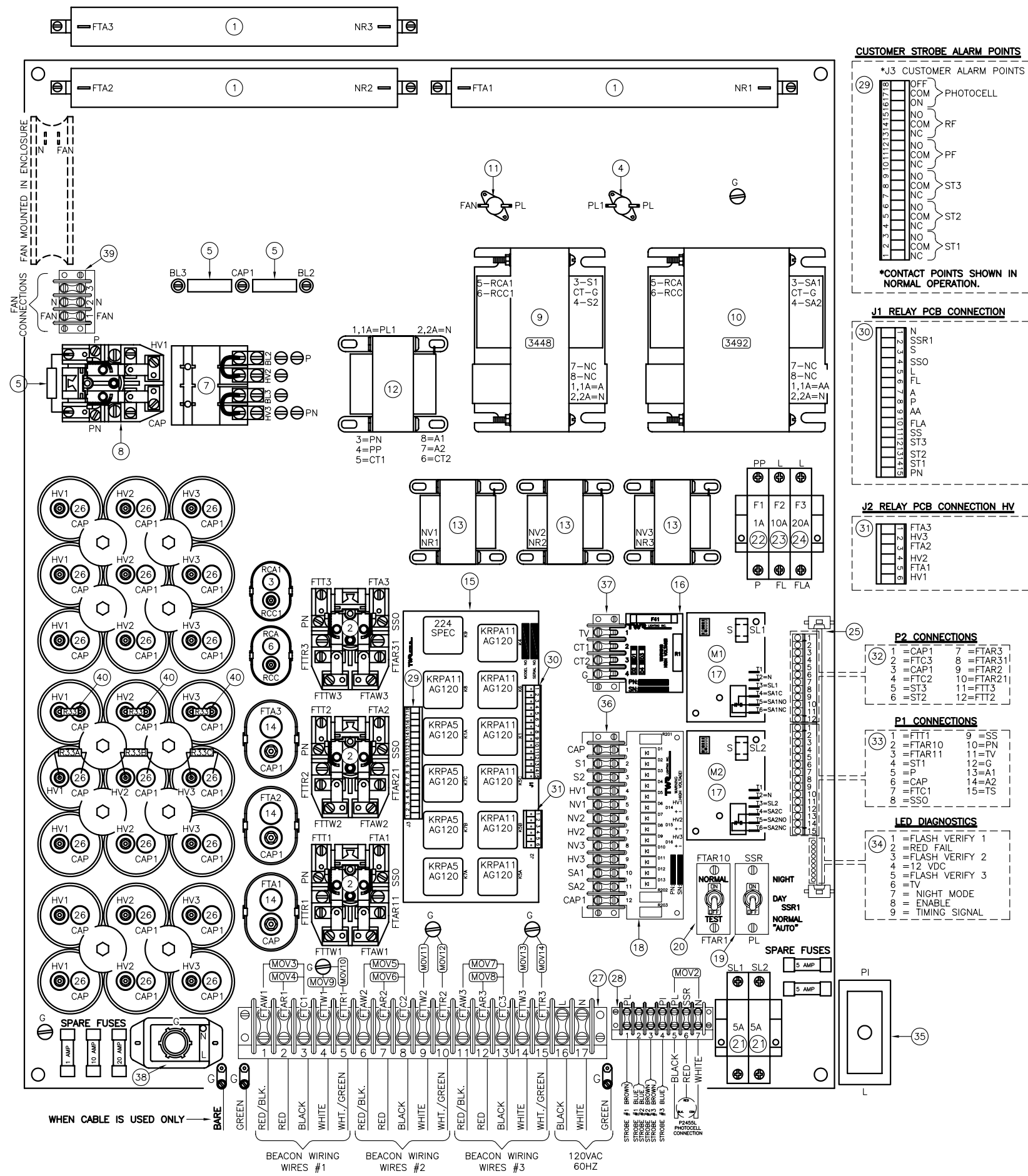

ITEM NO.	SCH. TAG NO.	DESCRIPTION
1	R31A,R31B,R31C	NIGHT MODE RESISTORS 50 OHM 225W
2	K3A,K3B,K3C	RED/WHITE RELAYS
3	C101	4uf 660VAC RESONANT CAPACITOR (T2)
4	TLS1	THERMAL LIMITING SWITCH 1 (OA-210)
5	R32A,R32B,R32C	BLEEDER RESISTORS
6	C101A	5uf RESONANT CAPACITOR (T2A)
7	K2A	BLEEDER RELAY 2
8	K2	BLEEDER RELAY 1
9	T2	FERRO TRANSFORMER 1
10	T2A	FERRO TRANSFORMER 2
11	TLS2	THERMAL LIMITING SWITCH 2 (CA-130)
12	T1	ISOLATION TRANSFORMER
13	T3A,T3B,T3C	BURSTING CHOKES
14	C102,C112,C122	NIGHT CAPACITORS 4uf @ 25KV
15	PCB3	RELAY PCB3 STH03279A
	K1	POWER RELAY
	K1A	POWER ALARM
	K4	PHOTOCELL RELAY
	K5A	NIGHT/DAY INTENSITY RELAY 1
	K5B	NIGHT/DAY INTENSITY RELAY 2
	K5C	NIGHT/DAY INTENSITY RELAY 3
	K6	SIDLIGHT POWER RELAY
	K7A	STROBE FAIL RELAY 1
	K7B	STROBE FAIL RELAY 2
	K7C	STROBE FAIL RELAY 3
	K8	RED STROBE ALARM/FAIL
	K9	TRANSFER RELAY
16	PCB4	TRIGGER VOLTAGE PCB4
17	M1,M2	SCR430T CURRENT SENSOR
18	PCB2	HV RECTIFIER PCB2
19	SW1	PHOTOCELL BYPASS SWITCH
20	SW2	RED STROBE FAILURE
21	SL1,SL2	SIDLIGHT FUSES
22	F1	.5 AMP FUSE
23	F2	10 AMP FUSE
24	F3	20 AMP FUSE
25	PCB1	CONTROL PCB
26	C103-C131	DAY CAPACITORS 40uf @ 1.1KV
27	TB1	TERMINAL BLOCK 1
28	TB2	TERMINAL BLOCK 2
29	J3	CUSTOMER ALARM POINTS
30	J1	RELAY PCB CONNECTION
31	J2	RELAY PCB CONNECTION HV
32	P2	CONTROL PCB CONNECTION 2
33	P1	CONTROL PCB CONNECTION 1
34	LED	DIAGNOSTIC LEDS
35	CSS	CABINET SAFETY SWITCH
36	TB3	HV PCB TERMINAL BLOCK
37	TB4	TV PCB TERMINAL BLOCK
38	MOVMOD	SURGE ARRESTOR
39	TB5	FAN CONNECTIONS
40	R33A,R33B,R33C	2.4 MEG 2W AUXILIARY BLEEDER RES.

- NOTES:
1. USE BUSSMANN KTK FUSES. SIZE AS SHOWN ON FUSE BLOCKS.
 2. WIRES ARE CONNECTED LETTER TO LETTER. (EXAMPLE: N TO N TO N)
 3. THIS DRAWING IS PROVIDED AS A GENERAL REFERENCE. TWR LIGHTING, INC. DOCUMENTATION SUPERCEDES THIS DRAWING AND SHOULD BE REVIEWED PRIOR TO INSTALLATION OF THIS SYSTEM.
 - **4. FILTER MAINTENANCE/CLEANING SHOULD BE PERFORMED MONTHLY (OR) AS REQUIRED FOR PROPER OPERATION.

**E-2/3DB CONTROLLER
CHASSIS LAYOUT**

APP'D	TWR Lighting, Inc. <i>Enlightened Technology</i>	SHEET SIZE	SHEET QTY.
CHK'D BY		B	1 OF 1
ENGINEER			
DRAWN BY	E.A.SALAZAR	SCALE	N.T.S.
DATE	07/09/98	DWG. NO.	H40-279

07/15/06	(H)	CHG. ITEM #15
DATE:	LTR.	REVISION

The use of non-TWR parts or modifications to original equipment design will void the manufacturer warranty and could invalidate the assurance of complying with FAA requirements as published in Advisory Circular 150/5345-43. NOTICE: The drawings and photographic images contained herein are the sole property of TWR Lighting, Inc. All information contained herein that is not generally known shall be considered confidential except to the extent the information has been previously established. The drawings and photographic images contained herein may not be reproduced, copied or used as the basis for manufacture or sale or promotion or any other purpose without the expressed written permission of TWR Lighting, Inc.

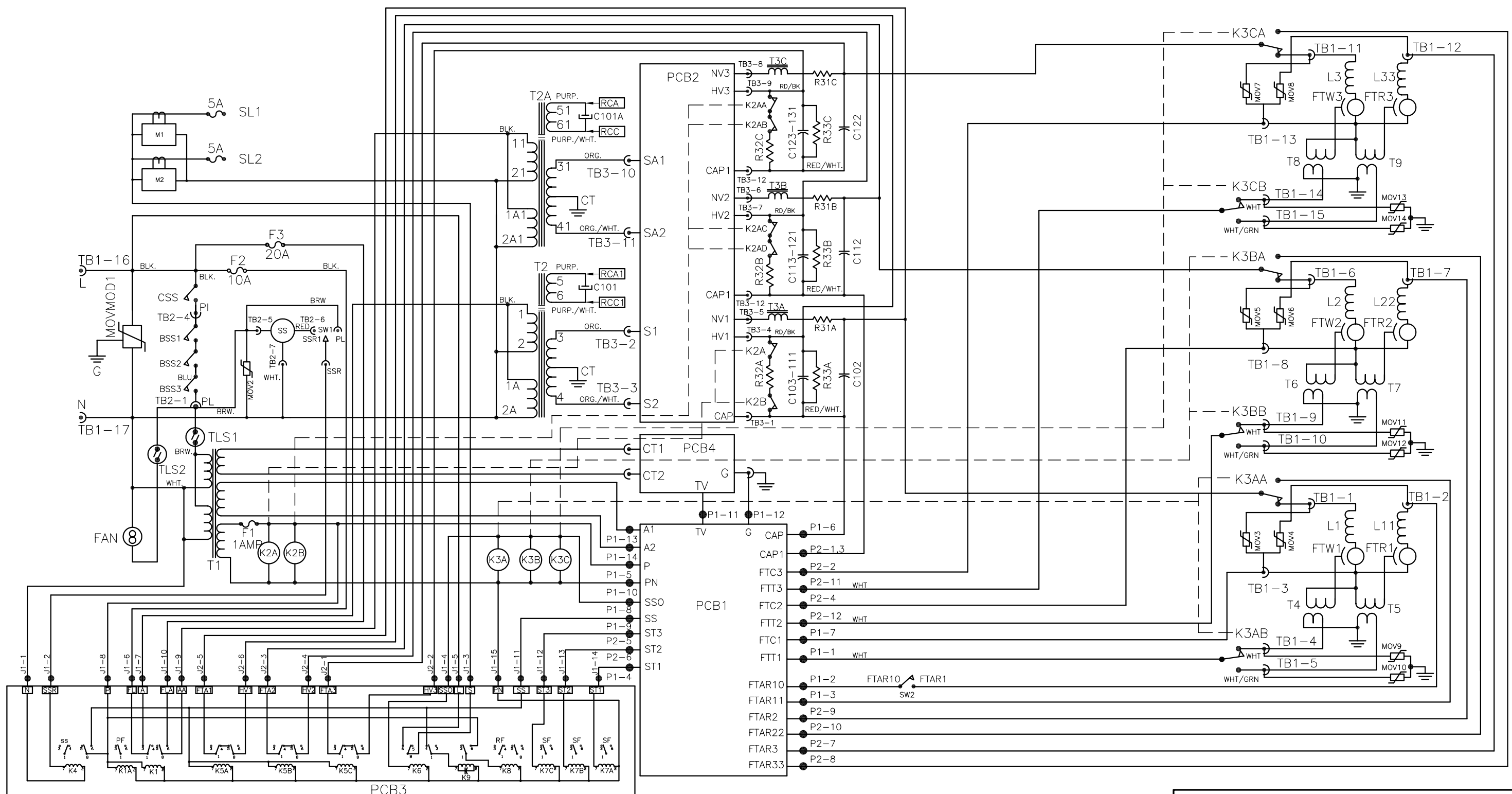

E-2/3DB SCHEMATIC

PROD DEPT	TWR Lighting, Inc. <i>Enlightened Technology</i>	SHEET SIZE	SHEET QTY.
SERV DEPT		B	1 OF 1
ENGINEER			
DRAWN BY	E.A.SALAZAR	DATE	07/10/98
SCALE	N.T.S.	DWG. NO.	M01-279

08/11/06	(F)	K7 labels
DATE:	LTR.	REVISION

The use of non-stock parts or modifications to original equipment design will void the manufacturer warranty and could invalidate the assurance of complying with FAA requirements as published in Advisory Circular 150/5345-43.
NOTICE: The drawings and photographic images contained herein are the sole property of TWR Lighting, Inc. All information contained herein that is not generally known shall be considered confidential except to the extent the information has been previously established. The drawings and photographic images contained herein may not be reproduced, copied or used as the basis for manufacture or sale or promotion or any other purpose without the expressed written permission of TWR Lighting, Inc.

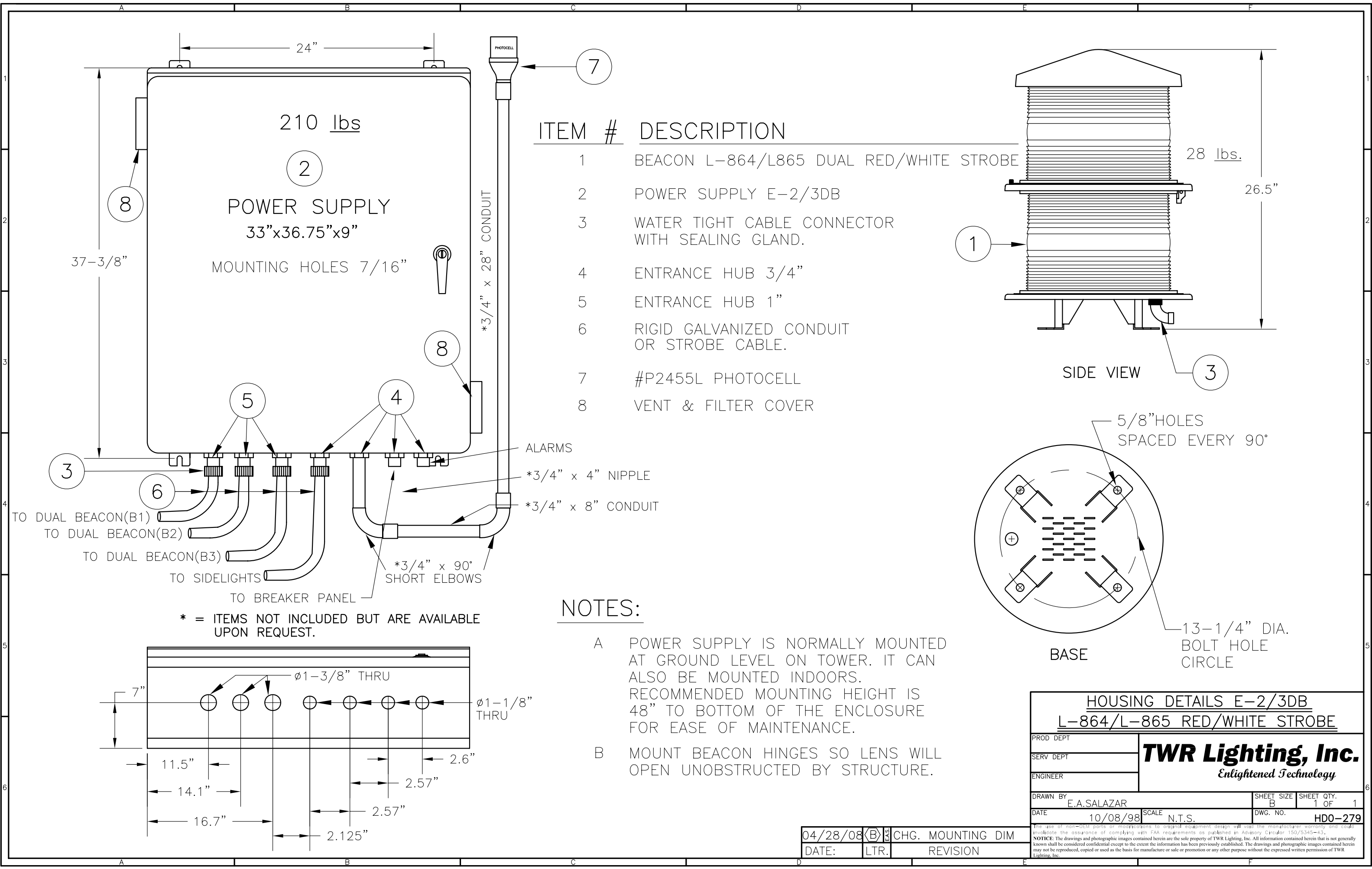

ITEM # DESCRIPTION

- 1 BEACON L-864/L865 DUAL RED/WHITE STROBE
- 2 POWER SUPPLY E-2/3DB
- 3 WATER TIGHT CABLE CONNECTOR WITH SEALING GLAND.
- 4 ENTRANCE HUB 3/4"
- 5 ENTRANCE HUB 1"
- 6 RIGID GALVANIZED CONDUIT OR STROBE CABLE.
- 7 #P2455L PHOTOCELL
- 8 VENT & FILTER COVER

SIDE VIEW

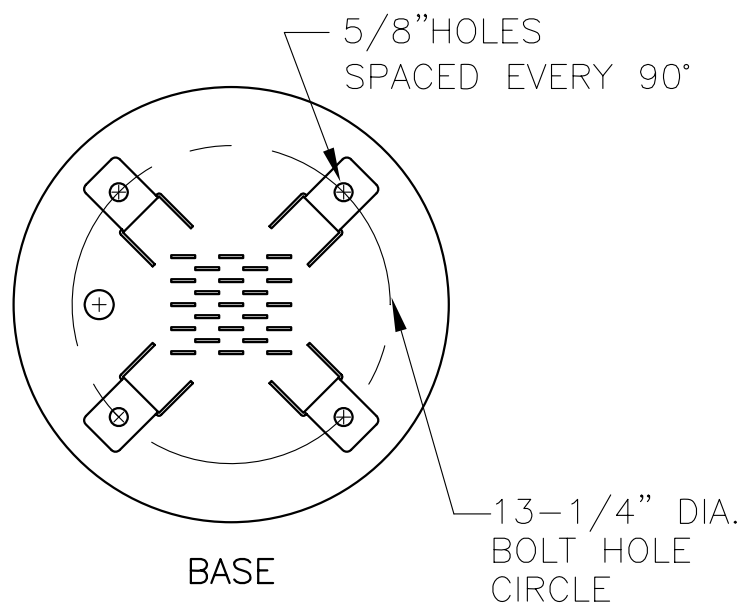

BASE

NOTES:

- A POWER SUPPLY IS NORMALLY MOUNTED AT GROUND LEVEL ON TOWER. IT CAN ALSO BE MOUNTED INDOORS. RECOMMENDED MOUNTING HEIGHT IS 48" TO BOTTOM OF THE ENCLOSURE FOR EASE OF MAINTENANCE.
- B MOUNT BEACON HINGES SO LENS WILL OPEN UNOBSTRUCTED BY STRUCTURE.

* = ITEMS NOT INCLUDED BUT ARE AVAILABLE UPON REQUEST.

HOUSING DETAILS E-2/3DB			
L-864/L-865 RED/WHITE STROBE			
PROD DEPT	TWR Lighting, Inc. <i>Enlightened Technology</i>		
SERV DEPT			
ENGINEER			
DRAWN BY E.A.SALAZAR	SHEET SIZE B	SHEET QTY. 1 OF 1	1
DATE 10/08/98	SCALE N.T.S.	DWG. NO. HDO-279	

04/28/08	(B)	CHG. MOUNTING DIM
DATE:	LTR.	REVISION

The use of non-TWR parts or modifications to original equipment design will void the manufacturer warranty and could invalidate the assurance of complying with FAA requirements as published in Advisory Circular 150/5345-43. NOTICE: The drawings and photographic images contained herein are the sole property of TWR Lighting, Inc. All information contained herein that is not generally known shall be considered confidential except to the extent the information has been previously established. The drawings and photographic images contained herein may not be reproduced, copied or used as the basis for manufacture or sale or promotion or any other purpose without the expressed written permission of TWR Lighting, Inc.

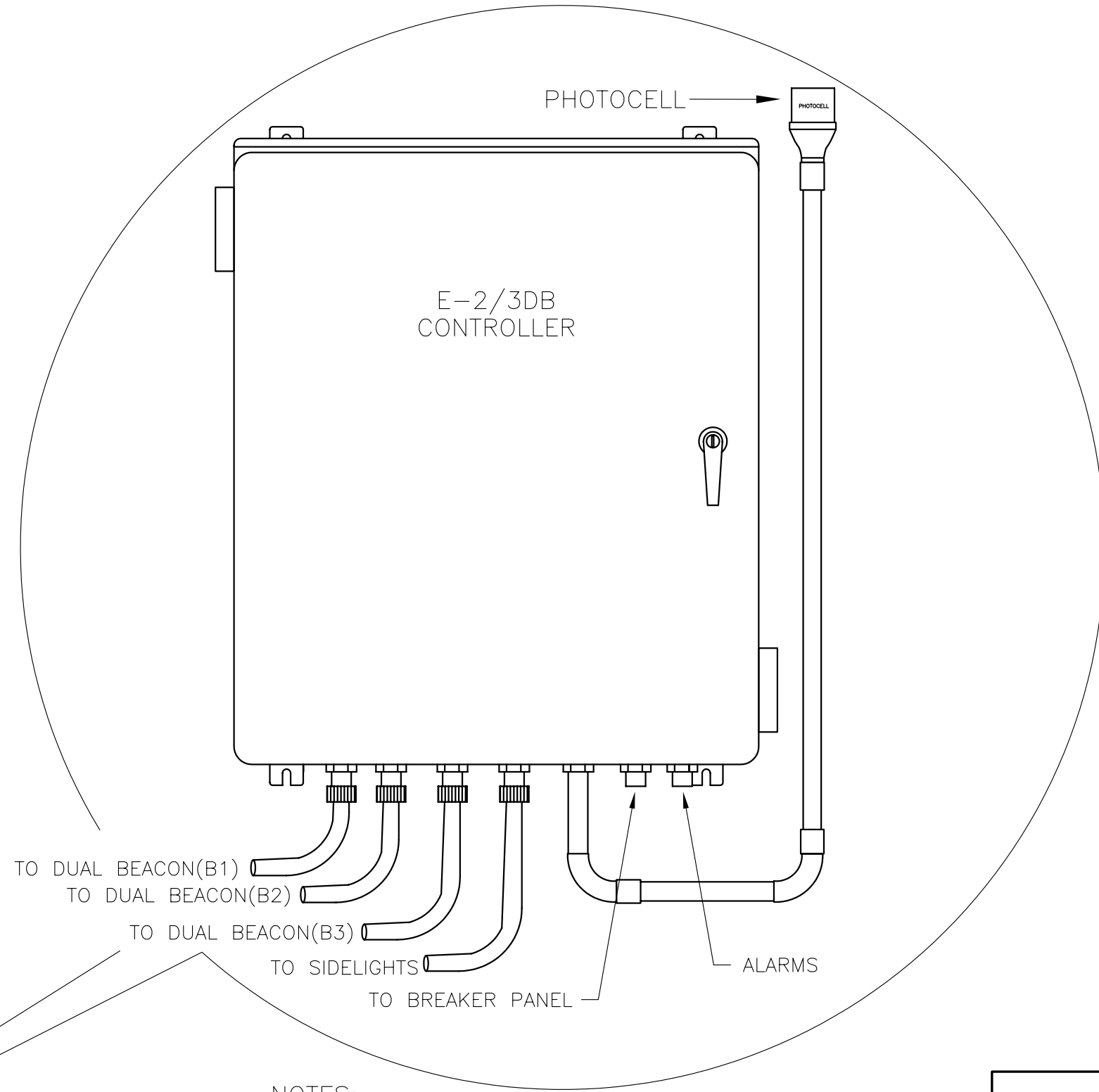
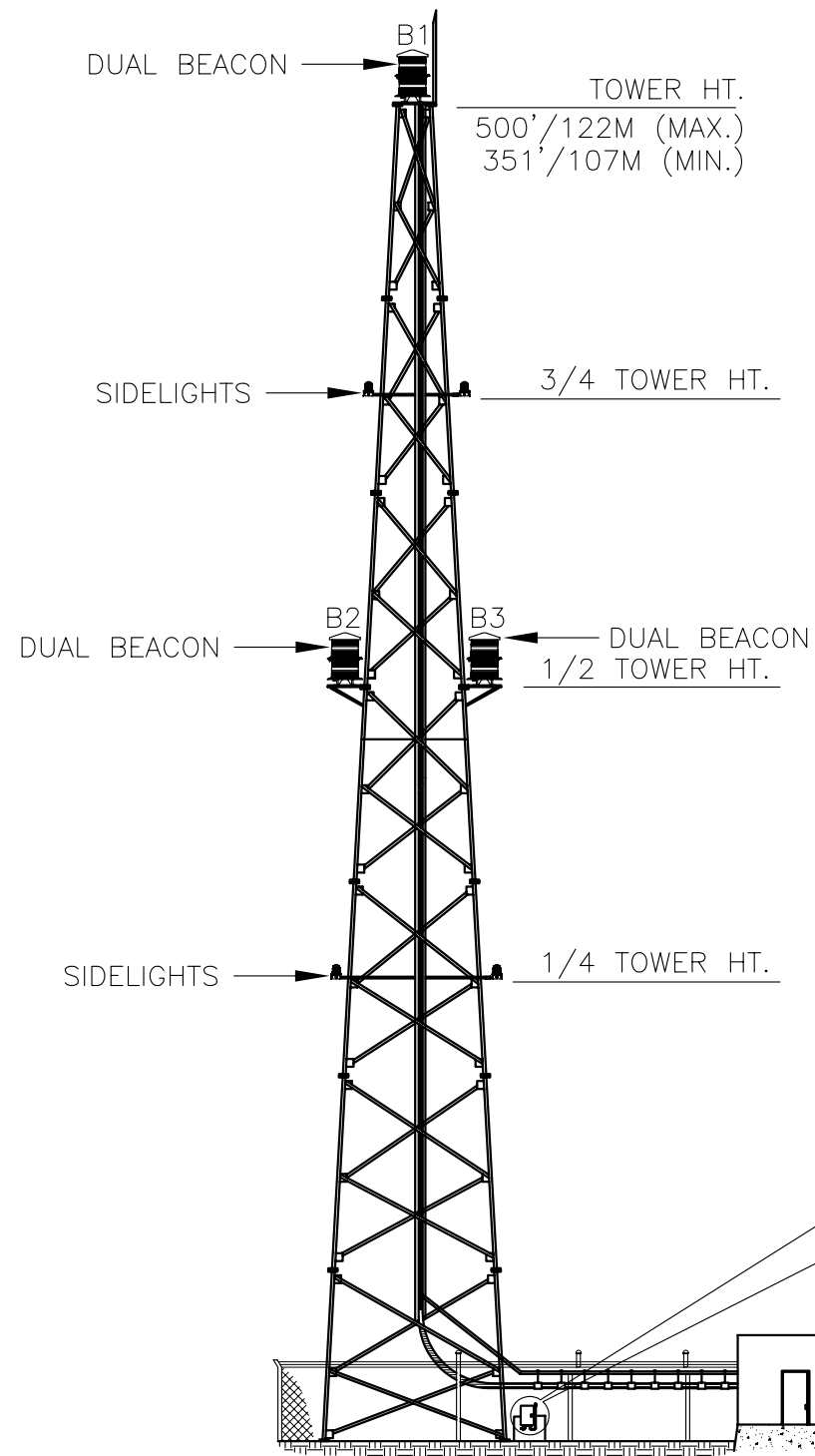

NOTES:

1. THIS CONTROLLER CAN BE MOUNTED INDOOR OR OUTDOOR.
2. IT IS HIGHLY RECOMMENDED TO MOUNT A LIGHTING ROD AT THE TOP LEVEL.
3. FOR MORE DETAILS REFER TO DRAWINGS HDO-279 (CONTROLLER INSTALLATION), 601 (LIGHT KIT CABLE RUN), 601-01(LIGHT KIT CONDUIT & CABLE RUN) AND 601-02 (LIGHT KIT ONLY CONDUIT RUN).

E-2/3DB INSTALLATION GUIDELINE

PROD DEPT	TWR Lighting, Inc. <i>Enlightened Technology</i>	SHEET SIZE	SHEET QTY.
SERV DEPT		B	1 OF 1
ENGINEER			
DRAWN BY	E.A.SALAZAR	SCALE	N.T.S.
DATE	10/08/98	DWG. NO.	INS-279

The use of non-stock parts or modifications to original equipment design will void the manufacturer warranty and could invalidate the assurance of complying with FAA requirements as published in Advisory Circular 150/5345-43.
NOTICE: The drawings and photographic images contained herein are the sole property of TWR Lighting, Inc. All information contained herein that is not generally known shall be considered confidential except to the extent the information has been previously established. The drawings and photographic images contained herein may not be reproduced, copied or used as the basis for manufacture or sale or promotion or any other purpose without the expressed written permission of TWR Lighting, Inc.

4

3

2

1

PARTS LIST		
ITEM	QTY	PART NUMBER
1	1	PHOTOCELL
2	2	6-32 x 1" SCREW
3	1	RECEPTACLE SOCKET
4	1	RECEPTACLE GASKET
5	1	RECEPTACLE HOUSING
6	1	1/2" CONDUIT LOCKNUT
7	1	3/4" TO 1/2" REDUCER

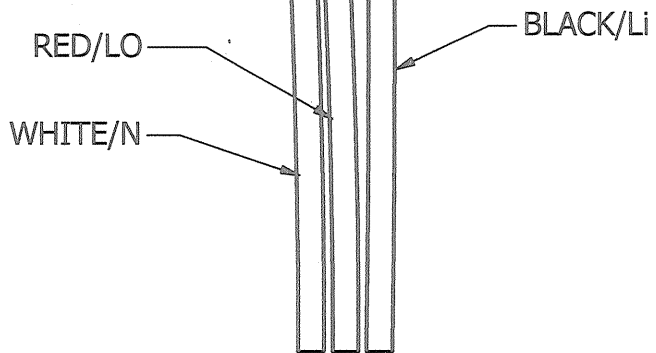
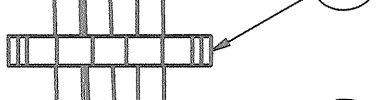
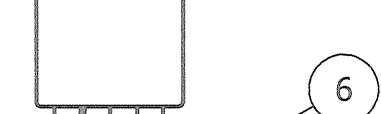
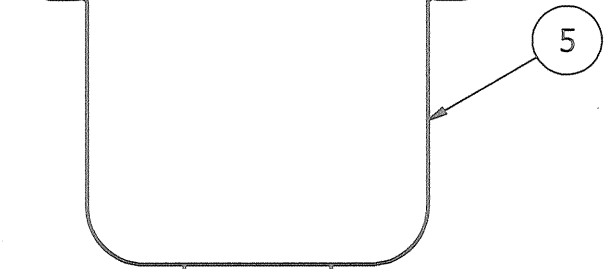
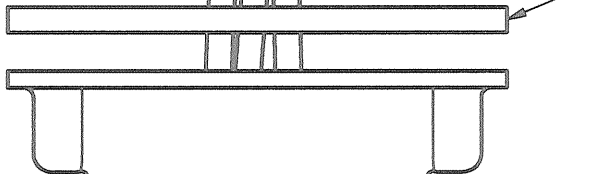
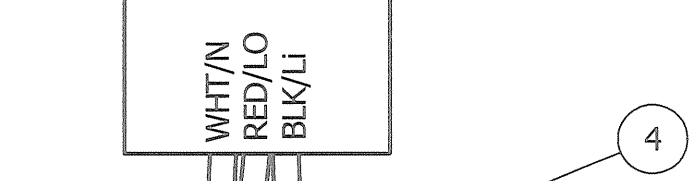
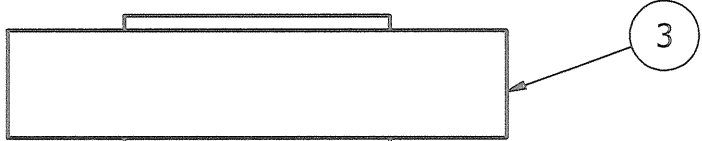
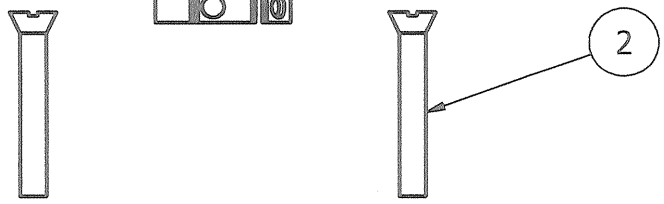
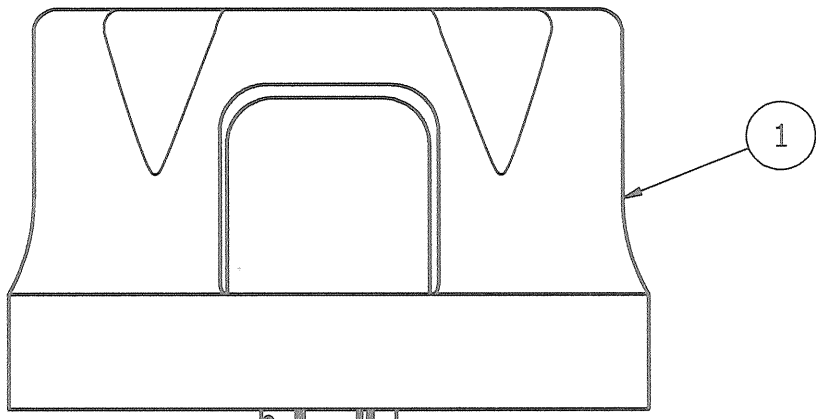

EXPLODED VIEW

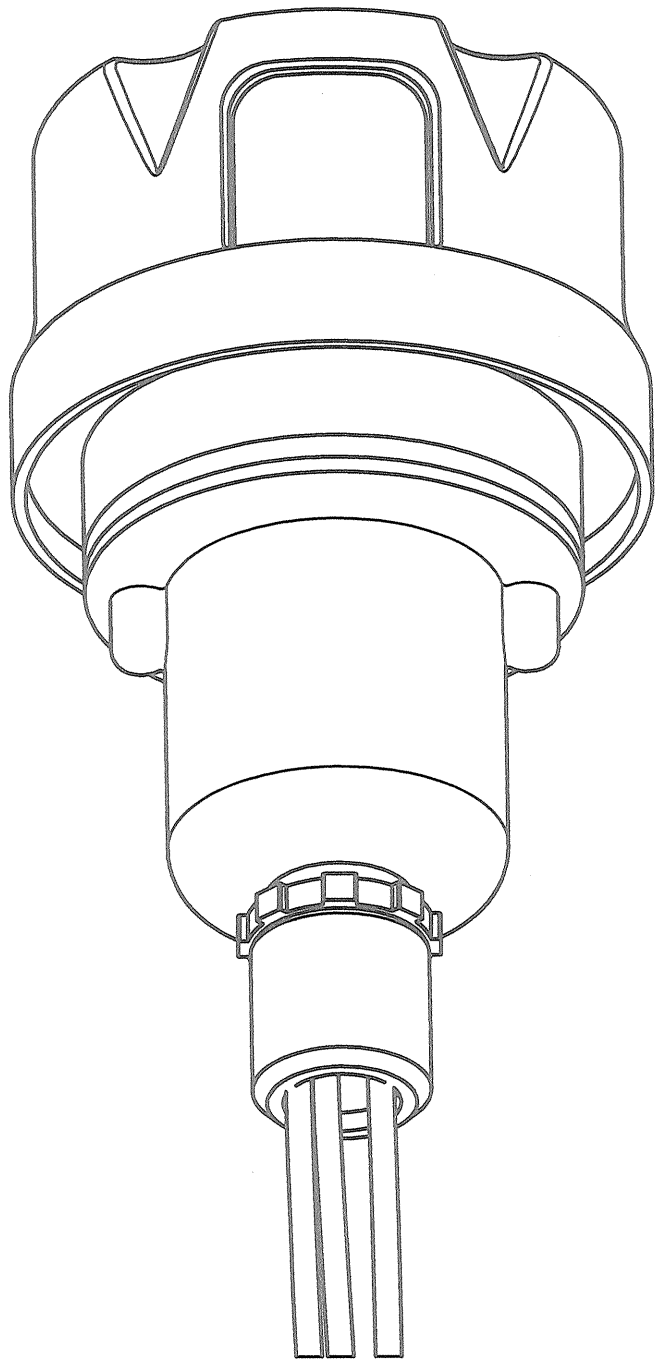

ASSEMBLY

NOTES:

- ITEM #7 CAN BE USED TO REDUCE 3/4" CONDUIT TO 1/2" CONDUIT AT THE HOUSING OR AT THE CONTROLLER ITSELF.
- IF ADDITIONAL WIRE IS REQUIRED OVER THE FACTORY 20', USE THE FOLLOWING CHART.
 21' TO 300' - 16 AWG TFFN
 301' TO 500' - 14 AWG TFFN

PHOTOCELL HOUSING DETAIL

PROD. DEPT
 SERV. DEPT
 ENGINEER

TWR Lighting, Inc. HARK
 Enlightened Technology®

DRAWN BY	vhernandez	SHEET SIZE	B	SHEET QTY.	1 OF 1
DATE	10/18/1995	SCALE	1/1	DWG. NO.	100239i

DATE	REV	AUTHOR	DESCRIPTION
02/03/2015	H	JZAMORANO	UPDATED NOTES

4

3

2

1

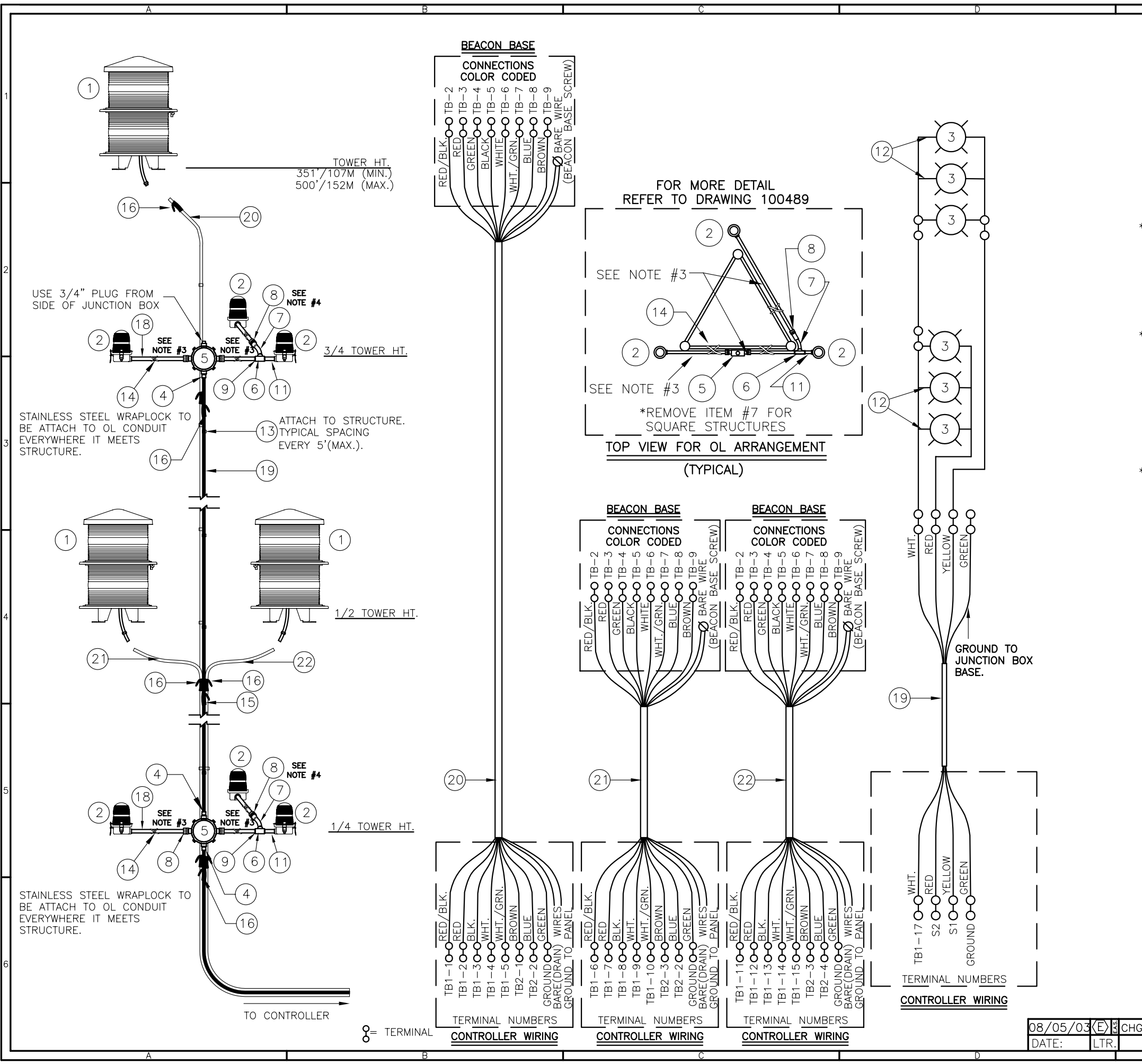

BILL OF MATERIALS

ITEM NO.	QTY.	TWR PART NO.	DESCRIPTION
1	3	STDBEACON	DUAL BEACON
2	6	OL1	3/4" OBSTRUCTION LIGHT
3	6	116A21TS	116 WATT 120 VOLT LAMP
4	3	CGB295SA	3/4" CORD CONNECTOR 0.50 - 0.625
5	2	JB5	3/4" JUNCTION BOX
6	2	T27CG	3/4" CONDULET W/COVER AND GASKET
7	2	EL3430	3/4" 30° ELBOW
8	6	HC-402	3/4" NO THREAD CONNECTOR
9	10	A314	3/4" CONDUIT LOCKNUTS
* 10	1	PIPDOP	4 oz. PIPE DOPE
11	2	N34T3	3/4" x 3" NIPPLE
12	6	SLPIGTAIL25	25' SIDELIGHT PIGTAIL
13	-	STCABLETIE	STROBE CABLE TIES(TWR. HEIGHT ÷ 5 x 2.75)
14	1	SS5012	STAINLESS STEEL WRAPLOCK 50' (FOR OLS)
15	3	CABLEGRIP1	SINGLE EYE LACE MESH 0.5 - 0.62
16	8	CABLEGRIP3	SINGLE EYE LACE MESH 0.63 - 0.74
* 17	1	STH40279	E2/3DB DUAL BEACON CONTROLLER
18	60'	CONDUIT34	3/4" CONDUIT (FOR OLS)

ITEM NUMBERS #19-#22 ARE NOT INCLUDED IN THE KIT BUT ARE AVAILABLE UPON REQUEST, AND REQUIRED FOR INSTALLATION.

19	-	STCABLEOB	OBSTRUCTION LIGHT CABLE(3/4 TWR. HT.+30'/9M)
20	-	STROBCABLE-3	STROBE CABLE (TWR. HT. + 30'/9M)
21	-	STROBCABLE-3	STROBE CABLE (1/2 TWR. HT. + 30'/9M)
22	-	STROBCABLE-3	STROBE CABLE (1/2 TWR. HT. + 30'/9M)

* = ITEMS NOT SHOWN

NOTES:

- 1) MOUNT BEACON HINGE SO LENS WILL OPEN UNOBSTRUCTED BY STRUCTURE.
- 2) ON AM RF TOWER APPLICATIONS, KEEP GROUND LUG FROM BEING CONNECTED TO EARTH GROUND. GROUND TO THE TOWER ONLY.
- 3) ITEM #18 CUT TO LENGTH FOR PROPER EXTENSION OF OL1 (6"-12") FROM STRUCTURE. ATTACH ITEM #8 TO UNTHREADED CONDUIT TO COMPLETE ASSEMBLY.
- 4) USE COUPLING THAT IS PROVIDED WITH ITEM #18 TO COUPLE ITEM #7 TO ITEM #8
- 5) THIS DRAWING IS PROVIDED AS A GENERAL REFERENCE. TWR LIGHTING, INC. DOCUMENTATION SUPERSEDES THIS DRAWING & SHOULD BE REVIEWED PRIOR TO INSTALLATION OF THIS SYSTEM.
- 6) POWER SUPPLY IS NORMALLY MOUNTED AT EYE LEVEL ON TOWER. IT CAN ALSO BE MOUNTED INDOORS. RECOMMENDED MOUNTING HEIGHT IS 42" TO BOTTOM OF THE ENCLOSURE FOR EASE OF MAINTENANCE.
- 7) STROBE CABLE IS TO BE FASTENED TO TOWER STRUCTURE WITH PART NUMBER STCABLETIE. (ATTACH EVERY 5')

LK1E2/3DB TOWER LIGHTING KIT CABLE RUN
(TOWERS 351'/107M TO 500'/152M)

PROD DEPT		TWR Lighting, Inc. <i>Enlightened Technology</i>	
SERV DEPT			
ENGINEER			
DRAWN BY	E.A.SALAZAR	SHEET SIZE	SHEET QTY.
DATE	11/20/97	B	1 OF 1
SCALE	N.T.S.	DWG. NO.	601

The use of non-TWR parts or modifications to original equipment design will void the manufacturer warranty and could invalidate the assurance of complying with FAA requirements as published in Advisory Circular 150/5345-43.
 NOTICE: The drawings and photographic images contained herein are the sole property of TWR Lighting, Inc. All information contained herein that is not generally known shall be considered confidential except to the extent the information has been previously established. The drawings and photographic images contained herein may not be reproduced, copied or used as the basis for manufacture or sale or promotion or any other purpose without the expressed written permission of TWR Lighting, Inc.

08/05/03 (E) CHG. WIRE CONNECTIONS
 DATE: LTR. REVISION

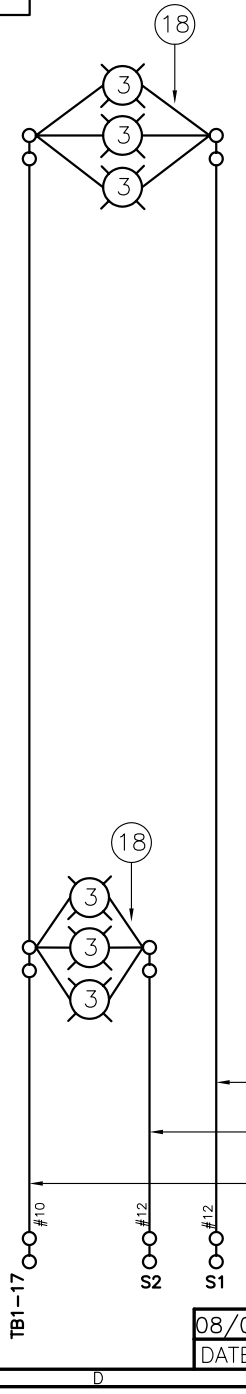
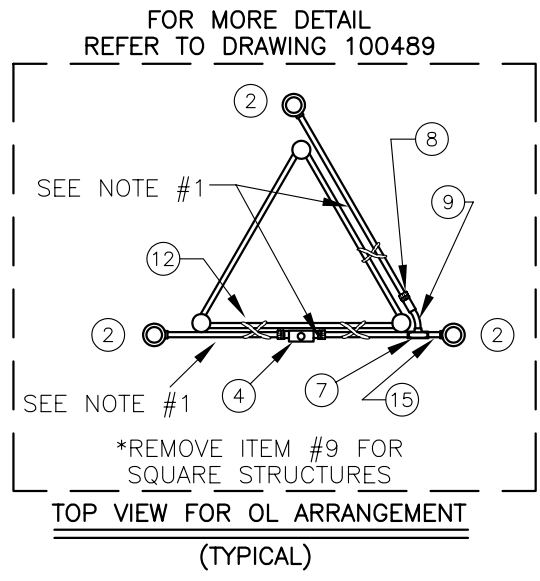
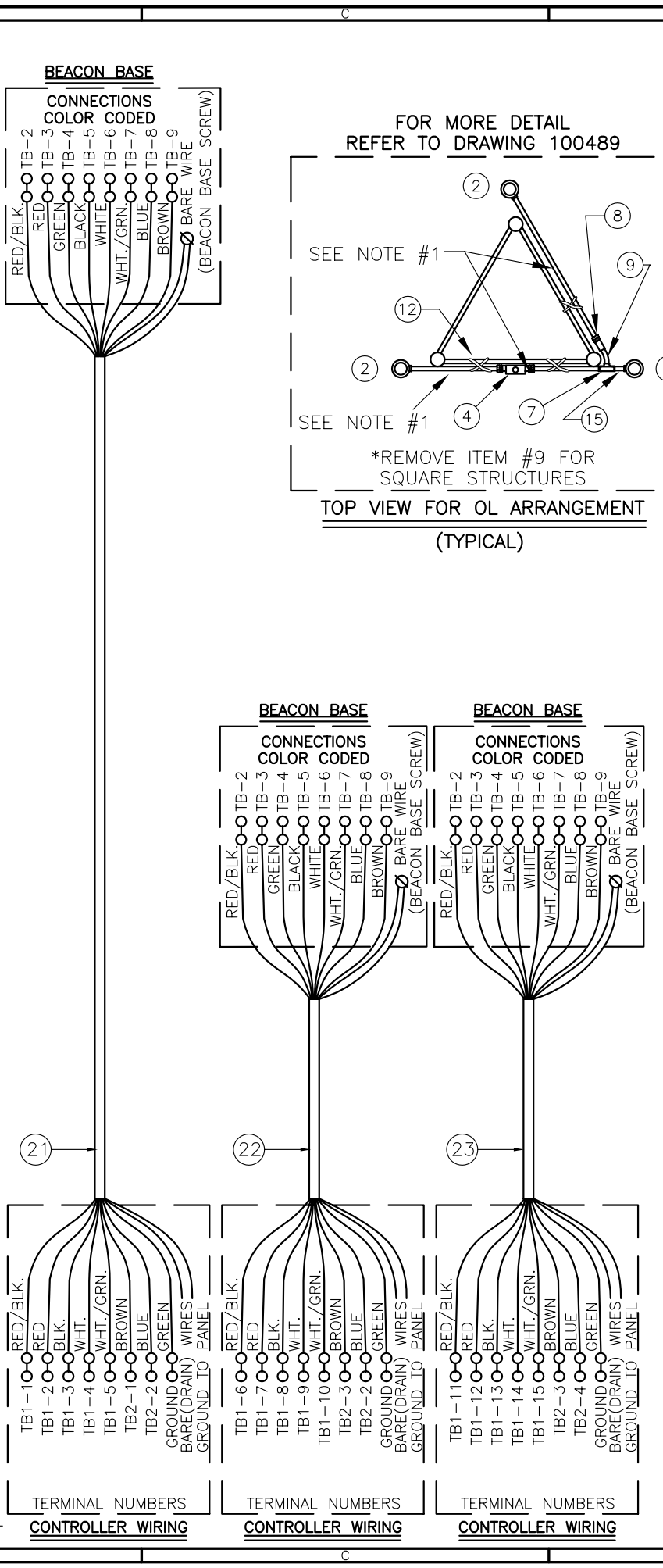
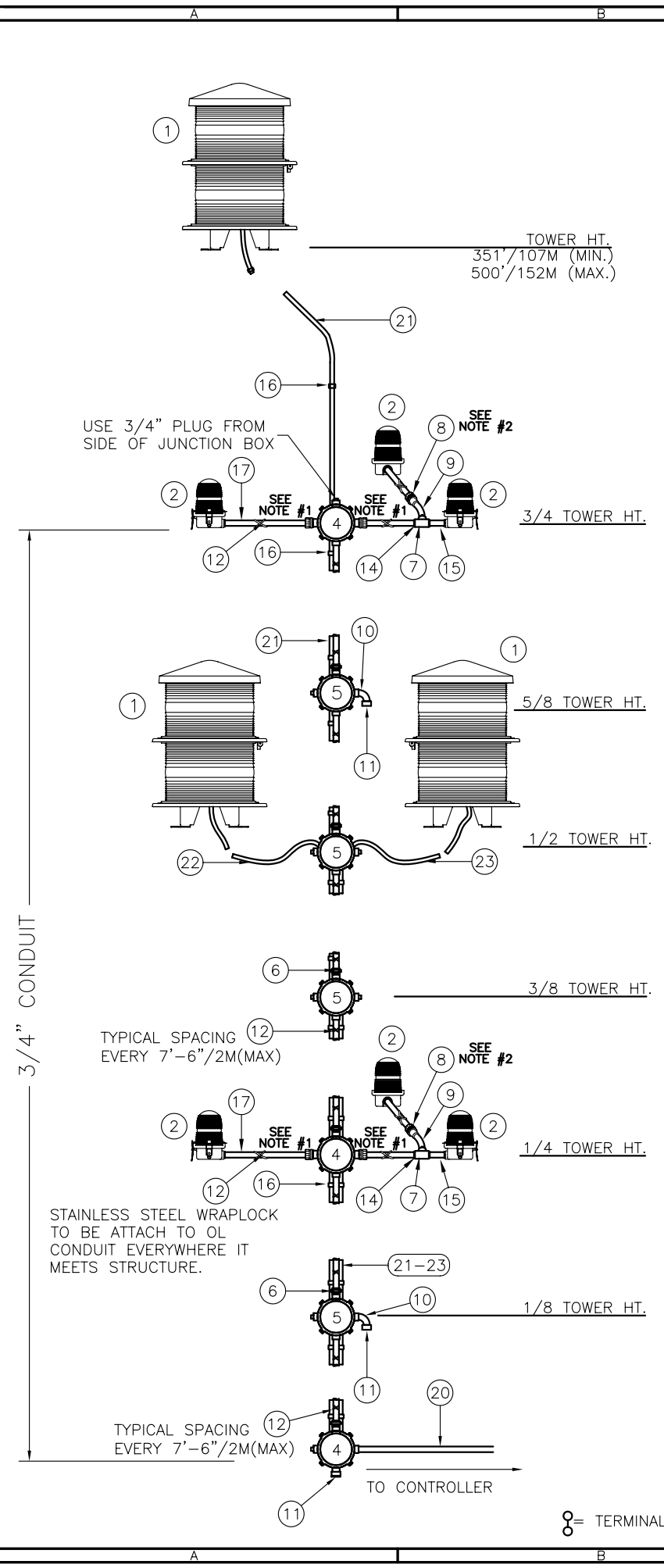

BILL OF MATERIALS			
ITEM NO.	QTY.	TWR PART NO.	DESCRIPTION
1	3	STDBEACON	DUAL BEACON
2	6	OL1	3/4" OBSTRUCTION LIGHT
3	6	116A21TS	116 WATT 120 VOLT LAMP
4	3	JB5	3/4" JUNCTION BOX
5	4	JB0	3/4" STRAIN RELIEF BOX
6	6	UNY205	3/4" UNION
7	2	T27CG	3/4" CONDULET W/COVER AND GASKET
8	6	HC402	3/4" NO THREAD CONNECTOR
9	2	EL3430	3/4" 30° ELBOW
10	2	EL3490	3/4" 90° SHORT ELBOW
11	3	5012902	3/4" BREATHER
12	1	SS10012	WRAPLOCK
* 13	1	PIPDOP	4 oz. PIPE DOPE
14	20	A314	3/4" CONDUIT LOCKNUTS
15	2	N34T3	3/4" x 3" NIPPLE
16	-	STCABLTI	STROBE CABLE TIES (TOWER HEIGHT + 5x2.75)
17	60'	CONDUIT34	3/4" CONDUIT (FOR OLS)
18	6	SLPIGTAIL25	25' SIDELIGHT PIGTAIL
* 19	1	STH40279	E2/3DB DUAL BEACON CONTROLLER

ITEM NUMBERS #20-#26 ARE NOT INCLUDED IN THE KIT BUT ARE AVAILABLE UPON REQUEST, AND REQUIRED FOR INSTALLATION.

20	-	CONDUIT34	3/4" CONDUIT (3/4 TOWER HT. + 30'/9M)
21	-	STROBCABLE-3	STROBE CABLE (TOWER HT. + 40'/12M)
22	-	STROBCABLE-3	STROBE CABLE (1/2 TOWER HT. + 40'/12M)
23	-	STROBCABLE-3	STROBE CABLE (1/2 TOWER HT. + 40'/12M)
24	-	10THHNWHT	#10 THHN WHITE WIRE(3/4 TWR HT.+40'/12M)
25	-	12THHNBLK	#12 THHN BLK. WIRE (1/4 TWR HT.+40'/12M)
26	-	12THHNRED	#12 THHN RED WIRE (3/4 TWR HT.+40'/12M)

* = ITEMS NOT SHOWN

- NOTES:**
- 1) ITEM #17 CUT TO LENGTH FOR PROPER EXTENSION OF OL1 (6"-12") FROM STRUCTURE. ATTACH ITEM #8 TO UNTHREADED CONDUIT TO COMPLETE ASSEMBLY.
 - 2) USE COUPLING THAT IS PROVIDED WITH ITEM #17.
 - 3) MOUNT BEACON HINGE SO LENS WILL OPEN UNOBSTRUCTED BY STRUCTURE.
 - 4) ON AM TOWER APPLICATIONS, KEEP GROUND LUG FROM BEING CONNECTED TO EARTH GROUND. GROUND TO THE TOWER ONLY.
 - 5) THIS DRAWING IS PROVIDED AS A GENERAL REFERENCE. TWR LIGHTING, INC. DOCUMENTATION SUPERSEDES THIS DRAWING & SHOULD BE REVIEWED PRIOR TO INSTALLATION OF THIS SYSTEM.
 - 6) POWER SUPPLY IS NORMALLY MOUNTED AT EYE LEVEL ON TOWER. IT CAN ALSO BE MOUNTED INDOORS. RECOMMENDED MOUNTING HEIGHT IS 42" TO BOTTOM OF THE ENCLOSURE FOR EASE OF MAINTENANCE.
 - 7) STROBE CABLE IS TO BE FASTENED TO TOWER STRUCTURE WITH PART NUMBER STCABLTI. (ATTACH EVERY 5'.)

LK2E2/3DB TOWER LIGHTING KIT CABLE RUN
(TOWERS 351'/107M TO 500'/152M)

PROD DEPT	TWR Lighting, Inc. <i>Enlightened Technology</i>	SHEET SIZE	SHEET QTY.
SERV DEPT		B	1 OF 1
ENGINEER			
DRAWN BY	E.A.SALAZAR	SCALE	N.T.S.
DATE	11/20/97	DWG. NO.	601-01

DATE: 08/05/03 LTR. CHG. WIRE CONNECTIONS REVISION

The use of non-TWR parts or modifications to original equipment design will void the manufacturer warranty and could invalidate the assurance of complying with FAA requirements as published in Advisory Circular 150/5345-43. NOTICE: The drawings and photographic images contained herein are the sole property of TWR Lighting, Inc. All information contained herein that is not generally known shall be considered confidential except to the extent the information has been previously established. The drawings and photographic images contained herein may not be reproduced, copied or used as the basis for manufacture or sale or promotion or any other purpose without the expressed written permission of TWR Lighting, Inc.

BILL OF MATERIALS			
ITEM NO.	QTY.	TWR PART NO.	DESCRIPTION
1	3	OL1/LED	3/4" OBSTRUCTION LIGHT
2	1	T27CG	3/4" CONDULET W/COVER AND GASKET
3	1	EL3430	3/4" 30° ELBOW
4	1	N34T3	3/4" x 3" NIPPLE
5	3	HC402	3/4" NO THREAD CONNECTOR
6	5	A314	3/4" CONDUIT LOCKNUTS
7	30'	CONDUIT34	3/4" CONDUIT

* = ITEMS NOT SHOWN

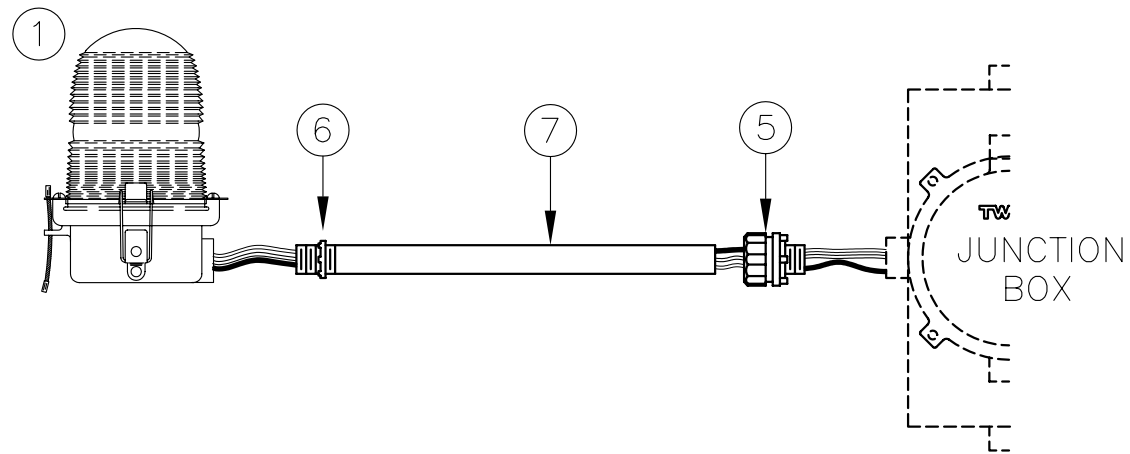

VIEW A

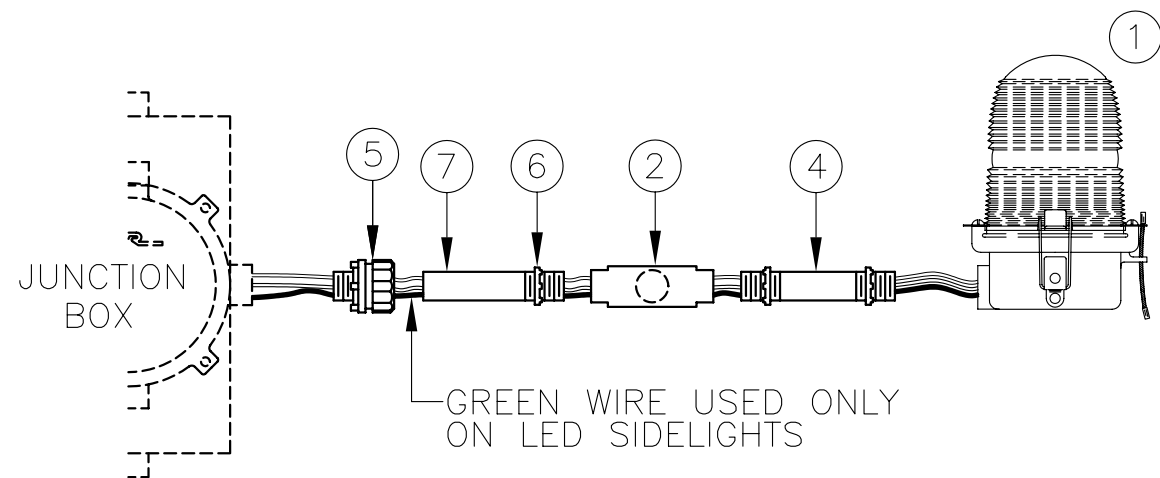

VIEW B

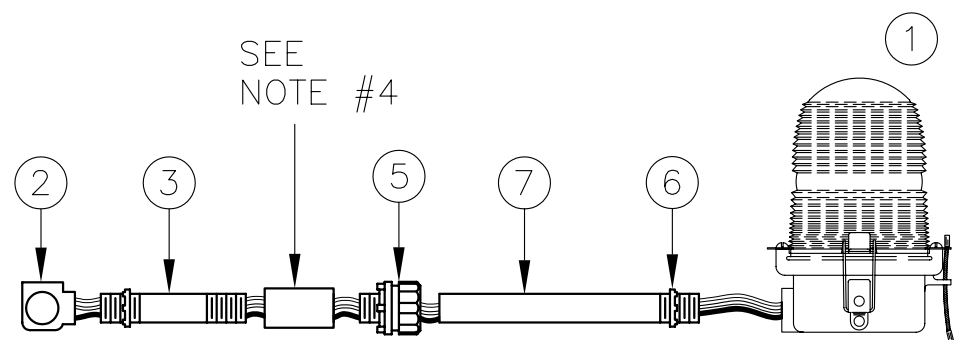

VIEW C

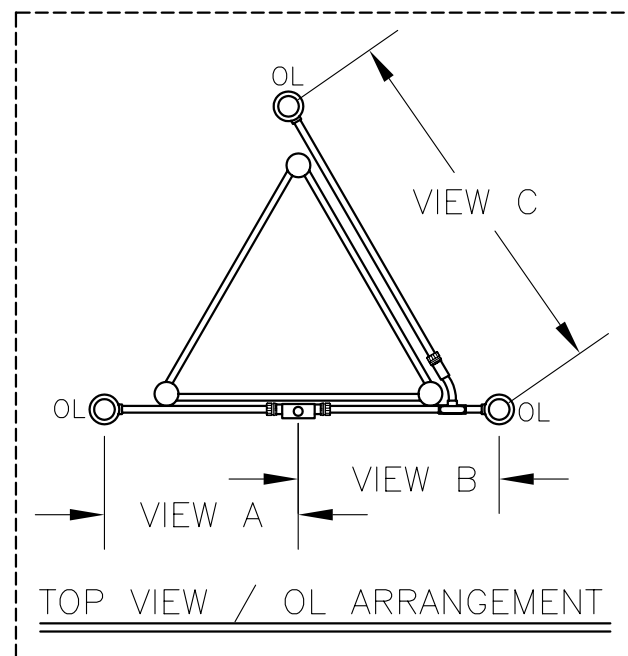

NOTES:

1. THIS DRAWING IS A TYPICAL INSTALLATION DETAIL FOR 3 OL-1 PER LEVEL SYSTEM.
2. IN VIEW C ITEM NUMBER 3 MAY BE OMITTED WHEN ARRANGING FOUR LEG TOWERS.
3. ITEMS #7 CUT TO LENGTH FOR PROPER EXTENSION OF OL1 FROM STRUCTURE (6"-12"). ATTACH ITEM #5 TO UNTHREADED CONDUIT TO COMPLETE ASSEMBLY.
4. USE COUPLING THAT IS PROVIDED BY ITEM #7.
5. GREEN WIRE USED ONLY ON LED SIDELIGHTS

SLASSM

SIDELIGHT MOUNT ASSEMBLY (10' FACE WIDTH MAX)

PROD DEPT	TWR Lighting, Inc. <i>Enlightened Technology</i>	
SERV DEPT		
ENGINEER		
DRAWN BY F.DELACRUZ	SHEET SIZE B	SHEET QTY. 1 OF 1
DATE 05/23/00	SCALE N.T.S.	DWG. NO. 100489

04/05/07	(A)	J.L.B.	UPDATED TO LED
DATE:	LTR.		REVISION

The use of non-UL listed parts or modifications to original equipment design will void the manufacturer warranty and could invalidate the assurance of complying with FAA requirements as published in Advisory Circular 150/5345-43.
NOTICE: The drawings and photographic images contained herein are the sole property of TWR Lighting, Inc. All information contained herein that is not generally known shall be considered confidential except to the extent the information has been previously established. The drawings and photographic images contained herein may not be reproduced, copied or used as the basis for manufacture or sale or promotion or any other purpose without the expressed written permission of TWR Lighting, Inc.

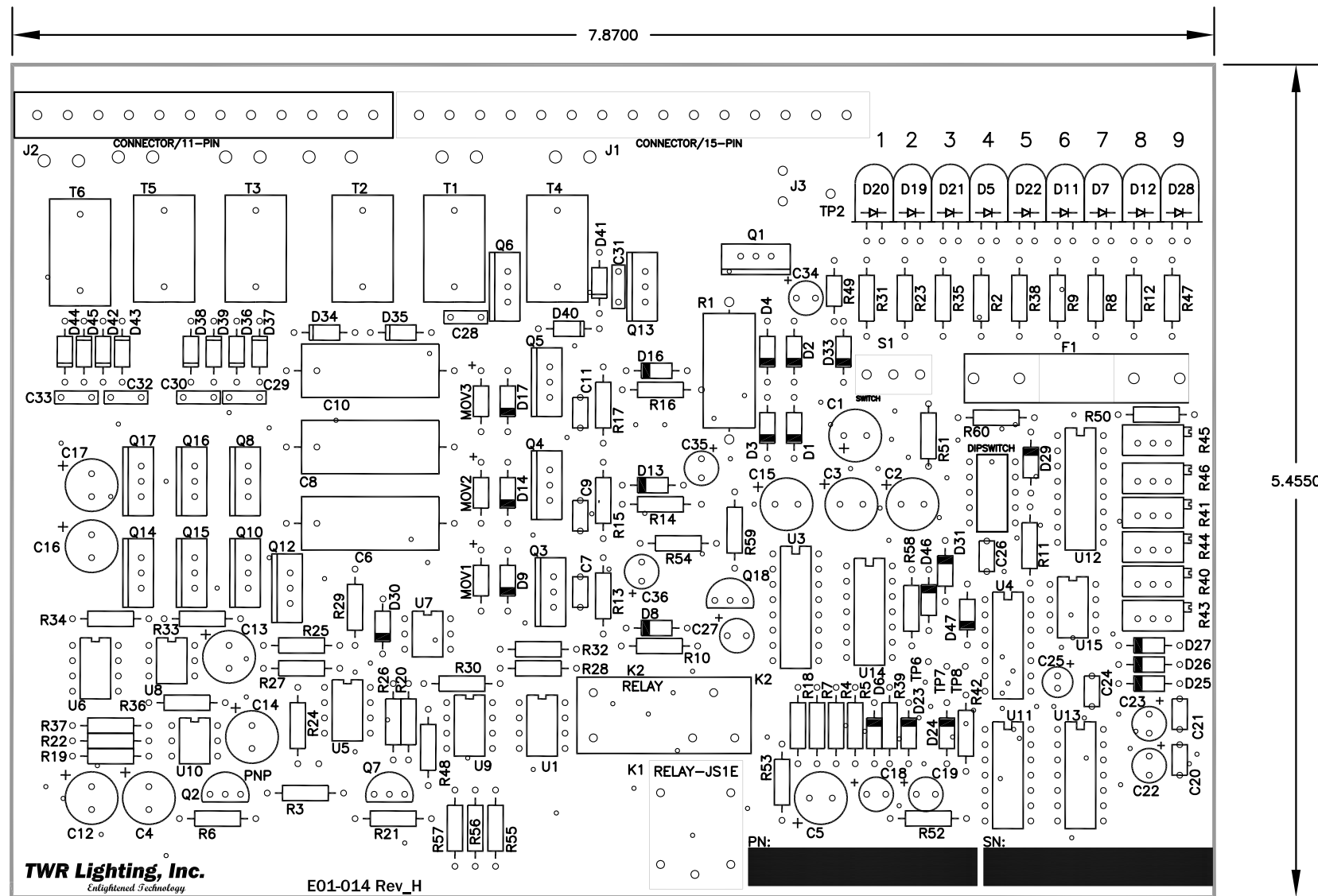

FACTORY SETUP:

MASTER & STAND ALONE

- 1 ON
- 2 OFF
- 3 ON
- 4 OFF
- 5 ON

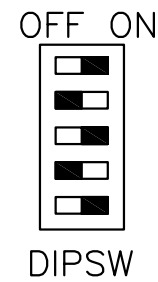

OPTIONAL SETUP:

SLAVE

- 1 OFF
- 2 ON
- 3 OFF
- 4 OFF
- 5 OFF

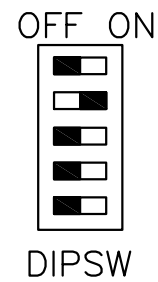

E-2/3DB CONTROL PCB

APP'D
CHK'D BY
ENGINEER

TWR Lighting, Inc.
Enlightened Technology

DRAWN BY
E.A.SALAZAR

SHEET SIZE
B

SHEET QTY.
1 OF 1

DWG. NO.
H01-279

DATE
10/08/98

SCALE
N.T.S.

09/08/06 (E) TRACK/COMPONENTS

DATE: LTR. REVISION

The use of non-stock parts or modifications to original equipment design will void the manufacturer warranty and could invalidate the assurance of complying with FAA requirements as published in Advisory Circular 150/5345-43.
NOTICE: The drawings and photographic images contained herein are the sole property of TWR Lighting, Inc. All information contained herein that is not generally known shall be considered confidential except to the extent the information has been previously established. The drawings and photographic images contained herein may not be reproduced, copied or used as the basis for manufacture or sale or promotion or any other purpose without the expressed written permission of TWR Lighting, Inc.

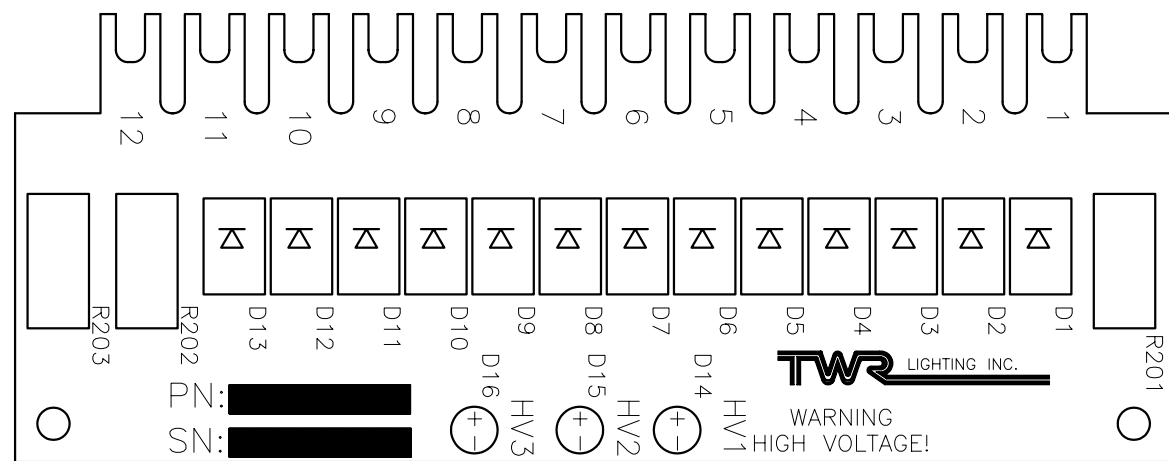

D-2/3LV/E-2/3DB(SL) HV RECTIFIER			
PCB2 L-865 MEDIUM INTENSITY STROBE			
PROD DEPT	TWR Lighting, Inc. Enlightened Technology		
SERV DEPT			
ENGINEER			
DRAWN BY E.A.SALAZAR	SHEET SIZE B	SHEET QTY. 1 OF 1	
DATE 06/15/95	SCALE FULL	DWG. NO. H02-258	

07/27/04	(C)	ADDED E2/3DBSL
DATE:	LTR.	REVISION

The use of non-OEM parts or modifications to original equipment design will void the manufacturer warranty and could invalidate the assurance of complying with FAA requirements as published in Advisory Circular 150/5345-43.
 NOTICE: The drawings and photographic images contained herein are the sole property of TWR Lighting, Inc. All information contained herein that is not generally known shall be considered confidential except to the extent the information has been previously established. The drawings and photographic images contained herein may not be reproduced, copied or used as the basis for manufacture or sale or promotion or any other purpose without the expressed written permission of TWR Lighting, Inc.

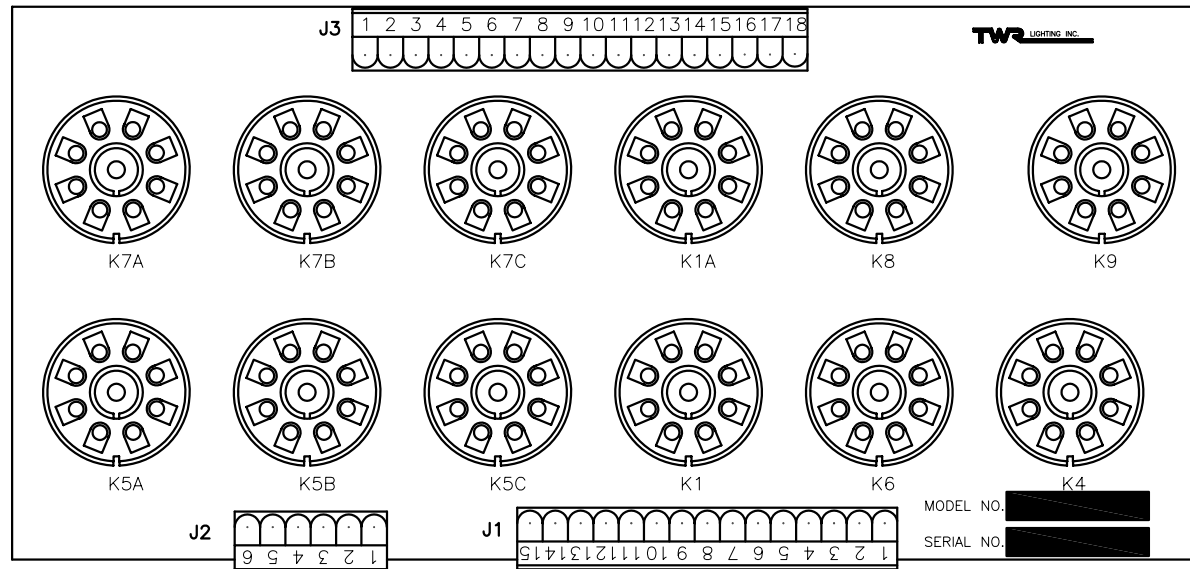

E2/3DB RELAY PCB3

PROD DEPT	TWR Lighting, Inc. <i>Enlightened Technology</i>	SHEET SIZE	SHEET QTY.
SERV DEPT		B	1 OF 1
ENGINEER			
DRAWN BY	E.A.SALAZAR	SCALE	N.T.S.
DATE	10/06/98	DWG. NO.	H03-279

05/16/03	(A)	REMOVED RELAYS
DATE:	LTR.	REVISION

The use of non-stock parts or modifications to original equipment design will void the manufacturer warranty and could invalidate the assurance of complying with FAA requirements as published in Advisory Circular 150/5345-43.
 NOTICE: The drawings and photographic images contained herein are the sole property of TWR Lighting, Inc. All information contained herein that is not generally known shall be considered confidential except to the extent the information has been previously established. The drawings and photographic images contained herein may not be reproduced, copied or used as the basis for manufacture or sale or promotion or any other purpose without the expressed written permission of TWR Lighting, Inc.

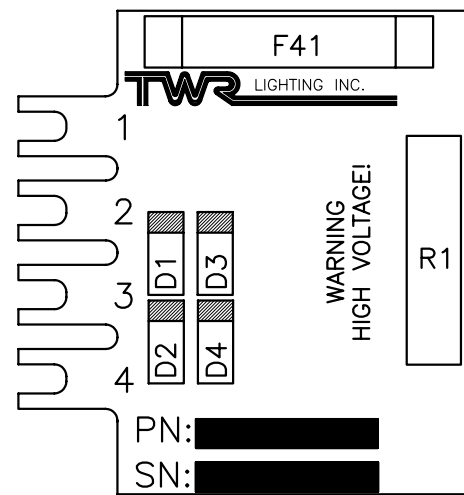

E-1DB/E-2/3DB TRIGGER VOLTAGE
RECTIFIER PCB (PCB4)

PROD DEPT
SERV DEPT
ENGINEER

TWR Lighting, Inc.
Enlightened Technology

DRAWN BY
E.A.SALAZAR

SHEET SIZE
B

SHEET QTY.
1 OF 1

DATE
06/13/97

SCALE
N.T.S.

DWG. NO.
H04-269

The use of non-OEM parts or modifications to original equipment design will void the manufacturer warranty and could invalidate the assurance of complying with FAA requirements as published in Advisory Circular 150/5345-43.
NOTICE: The drawings and photographic images contained herein are the sole property of TWR Lighting, Inc. All information contained herein that is not generally known shall be considered confidential except to the extent the information has been previously established. The drawings and photographic images contained herein may not be reproduced, copied or used as the basis for manufacture or sale or promotion or any other purpose without the expressed written permission of TWR Lighting, Inc.

TWR Lighting, Inc.

FAA Approved L-810

Single Obstruction Light Side Hub

OL1

FM10018_RD.DWG

For use as an obstruction light on towers, building, bridges, cooling towers.
Meets or exceeds all FAA specs as found in AC 150/5345-43 Type L-810.

Our most popular light. The side hub allows for a straight run of conduit
from the junction box for hook up.

High temperature, ultra pure
FAA approved Aviation red, blue,
yellow, or clear glass fresnel lens.

Can be used steady
burning or flashing.

Copper free aluminum casting and
all stainless steel latches and
hardware for corrosion protection.

Neoprene gasket for
weatherproofing.

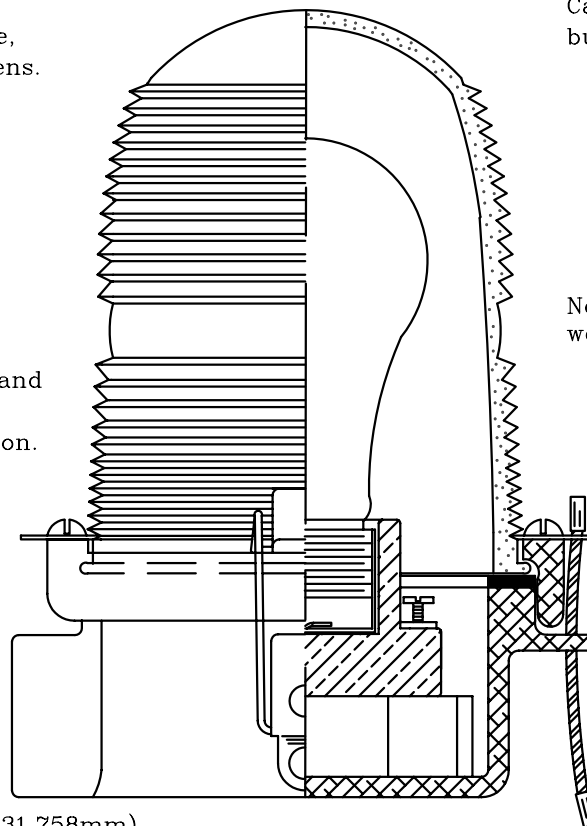

High quality porcelain
receptacle.

Stainless steel
safety cable.

Specify conduit size
3/4", 1", 1-1/4" NPT
(19.055mm), (25.407mm), (31.758mm)

General Specifications

Height 7.5 inches (19.055 cm)

Weight 3 lbs (13605.442g)

Power 120, 230, or 240 volts AC

Uses 116W, 120V or 240V bulbs

Bulbs sold separately

No special tools required for maintenance.

TWR Lighting, Inc.
4300 Windfern Rd. #100
Houston, Tx., 77041-8943
Phone: (713)973-6905
Fax: (713)973-9352
WEB SITE: <http://www.twrlighting.com>
©2003 TWR Lighting, Inc.

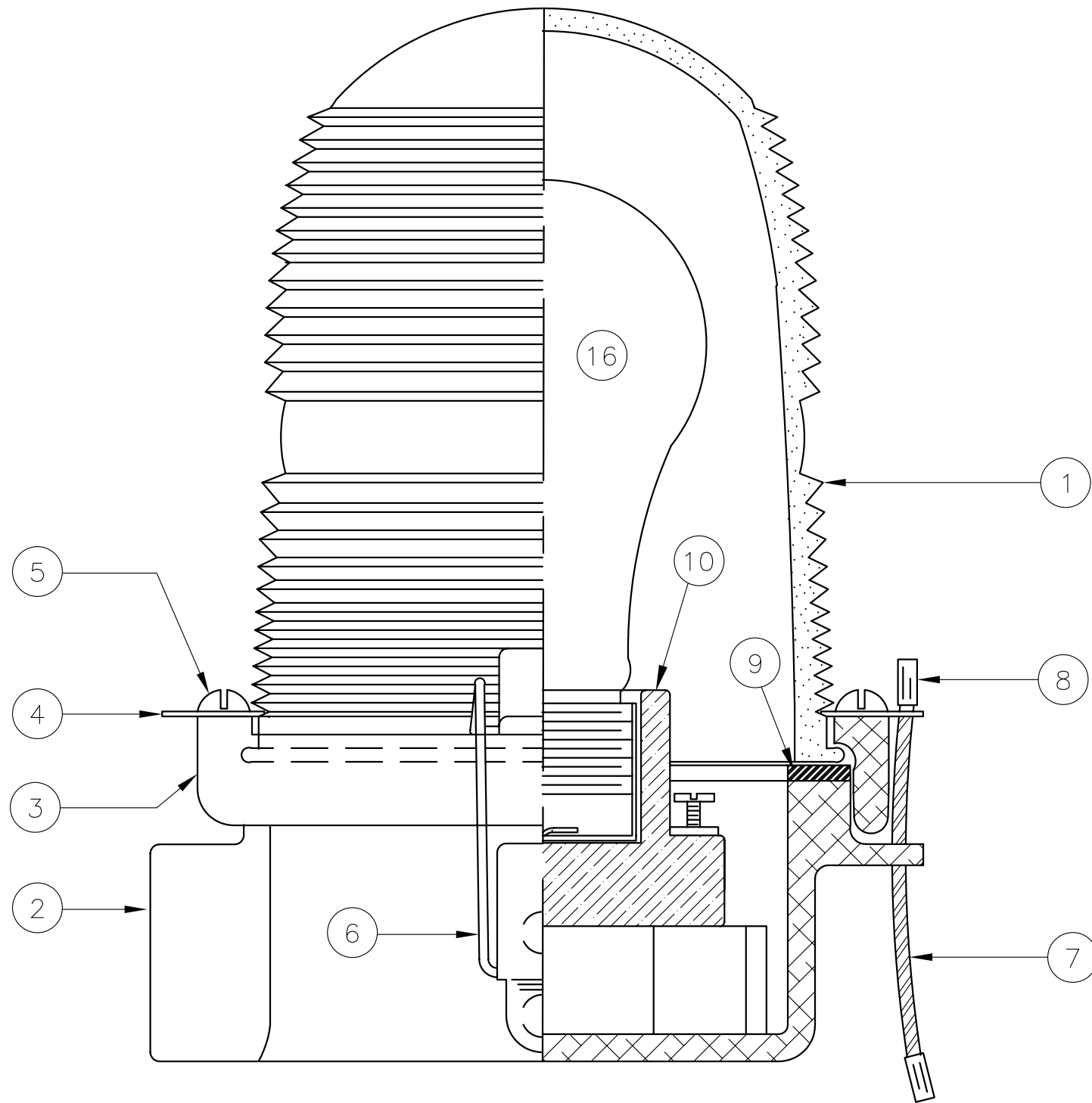

ITEM NO	QTY.	TWR PART NUMBER	DESCRIPTION
1	1	AP35222	RED SIDELIGHT GLASS
2	1	105C	SINGLE SIDELIGHT BODY
3	1	106C	LENS HOLDER RING
4	2	12V245	OL LENS CLIP
5	2	832X14PH	8-32 X 1/4" PH S.S. SLOT
6	2	HC255SS	SIDELIGHT LATCHES
7	1	7X7SS	1/16 7 X 7 S.S. WIRE
8	2	A1A	STAKON CRIMP
9	1	OLG	OL GASKET
10	1	19062	SIDELIGHT RECEPTACLE
*	4	18PRSS	1/8 POP RIVETS
*	1	A314	3/4" CONDUIT LOCKNUT
*	2	104G	WHITE TEFLON WASHER
*	2	832X34PH	8-32 X 3/4" S.S. RH SLOT
*	1	100327	OL-1 SERIAL NUMBER LABEL
~	1	116A21TS	116W-120V LAMP (TYP.)

*=PART NOT SHOWN
 ~=PART SOLD SEPARATELY

NOTE:

- FAA APPROVED LIGHT USES THE 116A21TS LAMP. OTHER LAMPS ARE AVAILABLE TO MEET YOUR APPLICATION.

OL1

3/4" OL-1 SIDE HUB ASSEMBLY DETAIL (PART #OL1)

PROD DEPT	TWR Lighting, Inc. <i>Enlightened Technology</i>	SHEET SIZE	SHEET QTY.
SERV DEPT		B	1 OF 1
ENGINEER		DWG. NO.	279-OL
DRAWN BY	E.A.SALAZAR	SCALE	FULL
DATE	1/7/92		

05/13/02	(B)	UPDATED B.O.M.
DATE:	LTR.	REVISION

The use of non-TWR parts or modifications to original equipment design will void the manufacturer warranty and could invalidate the assurance of complying with FAA requirements as published in Advisory Circular 150/5345-43.
 NOTICE: The drawings and photographic images contained herein are the sole property of TWR Lighting, Inc. All information contained herein that is not generally known shall be considered confidential except to the extent the information has been previously established. The drawings and photographic images contained herein may not be reproduced, copied or used as the basis for manufacture or sale or promotion or any other purpose without the expressed written permission of TWR Lighting, Inc.

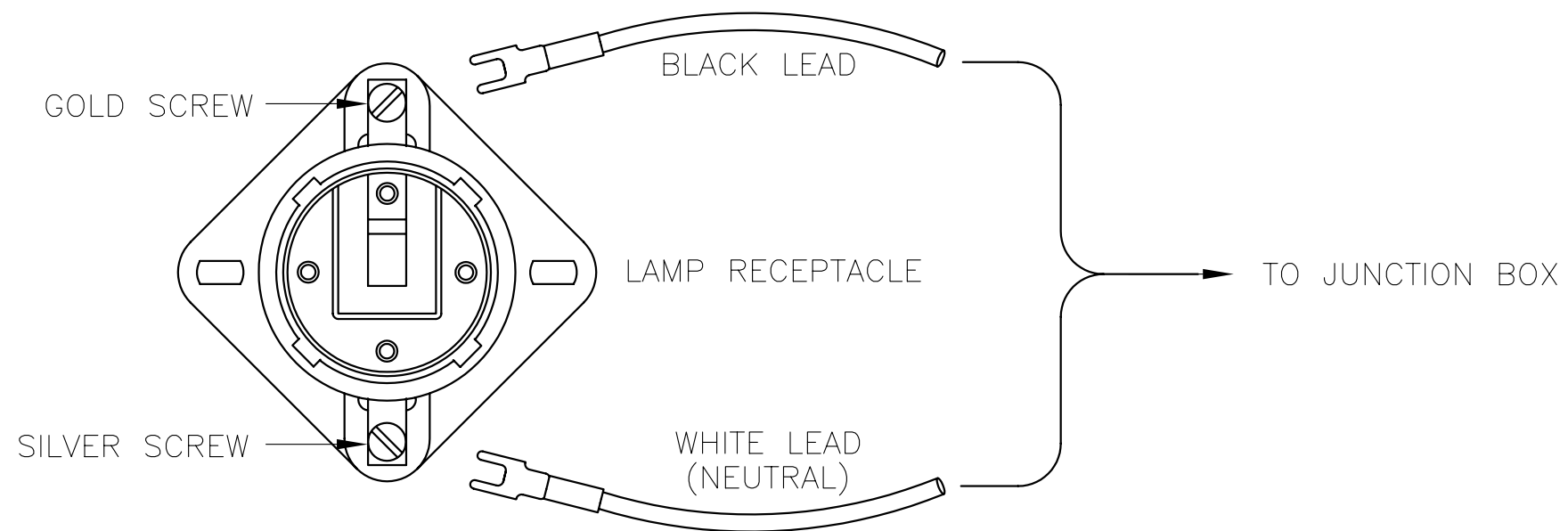

SIDELIGHT RECEPTACLE WIRING

PROD DEPT	TWR Lighting, Inc. <i>Enlightened Technology</i>	SHEET SIZE	SHEET QTY.
SERV DEPT		B	1 OF 1
ENGINEER			
DRAWN BY	G.D. SEBEK	SCALE	N.T.S.
DATE	06/08/91	DWG. NO.	274-S

7/2/98	(A)	CHANGED LABEL
DATE:	LTR.	REVISION

The use of non-TWR parts or modifications to original equipment design will void the manufacturer warranty and could invalidate the assurance of complying with FAA requirements as published in Advisory Circular 150/5345-43.
 NOTICE: The drawings and photographic images contained herein are the sole property of TWR Lighting, Inc. All information contained herein that is not generally known shall be considered confidential except to the extent the information has been previously established. The drawings and photographic images contained herein may not be reproduced, copied or used as the basis for manufacture or sale or promotion or any other purpose without the expressed written permission of TWR Lighting, Inc.

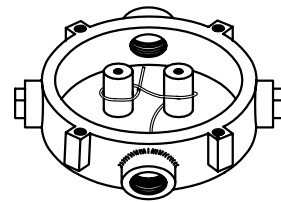
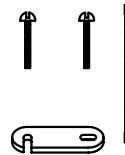
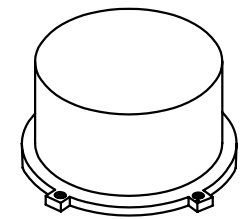
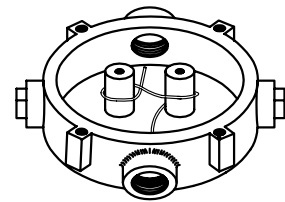
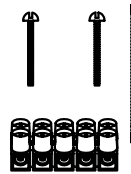
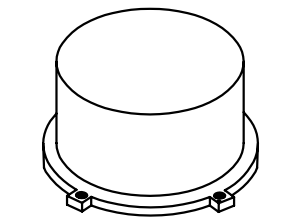

JB-5 AND JB-0
3/4" JUNCTION BOX

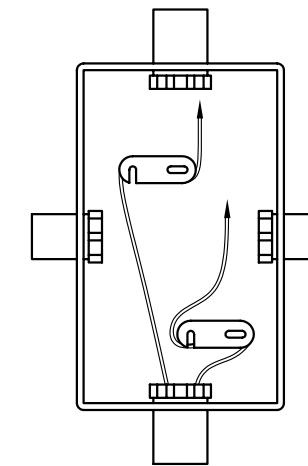
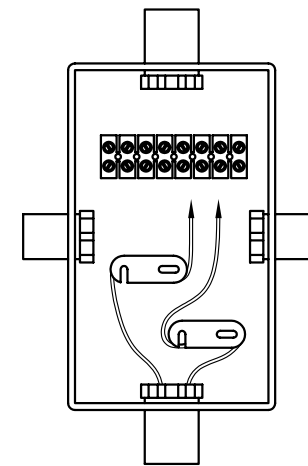

JB-8 AND JB-8SR
1" JUNCTION BOX

NOTES:

- 1) DRAWING ILLUSTRATES METHOD OF STRAIN RELIEVING WIRE. USE THIS METHOD ON ALL JUNCTION BOXES.
- 2) THE NATIONAL ELECTRICAL CODE-ARTICLE 300-19-B3 REQUIRES CONDUCTORS IN A VERTICAL CONDUIT BE SUPPORTED TO RELIEVE STRAIN ON TERMINAL BLOCK CONNECTIONS.
- 3) SKETCH ILLUSTRATES METHOD OF STRAIN RELIEVING A SINGLE CONDUCTOR. SEVERAL CONDUCTORS MAY BE GROUPED TOGETHER.
- 4) CONDUCTORS MAY BE MIXED BUT SHOULD NOT TAKE UP MORE THAN 40% OF CONDUIT'S INSIDE AREA.

USING THIS JUNCTION BOX METHOD SPACING IS 100 FEET MAXIMUM.

AWG WIRE SIZE	MAX. NUMBER WIRES IN 3/4" CONDUIT	MAX. NUMBER WIRES IN 1" CONDUIT	WIRE AREA SQ. INCHES	WEIGHT PER 100 FEET
12 THHN	16	26	0.0117	2.50
10 THHN	10	17	0.0184	4.10
8 THHN	6	9	0.0373	6.70
6 THHN	4	7	0.0519	10.30
4 THHN	2	4	0.0845	16.20

<u>JUNCTION AND STRAIN RELIEF BOXES</u>					
PROD DEPT	TWR Lighting, Inc. <i>Enlightened Technology</i>				
SERV DEPT					
ENGINEER					
DRAWN BY	G.D. SEBEK	SHEET SIZE	B	SHEET QTY.	1 OF 1
DATE	07/26/93	SCALE	N.T.S.	DWG. NO.	100089

9/29/00	(A)	UPDATED NOTES
DATE:	LTR.	REVISION

The use of non-TWR parts or modifications to original equipment design will void the manufacturer warranty and could invalidate the assurance of complying with FAA requirements as published in Advisory Circular 150/5345-43. NOTICE: The drawings and photographic images contained herein are the sole property of TWR Lighting, Inc. All information contained herein that is not generally known shall be considered confidential except to the extent the information has been previously established. The drawings and photographic images contained herein may not be reproduced, copied or used as the basis for manufacture or sale or promotion or any other purpose without the expressed written permission of TWR Lighting, Inc.

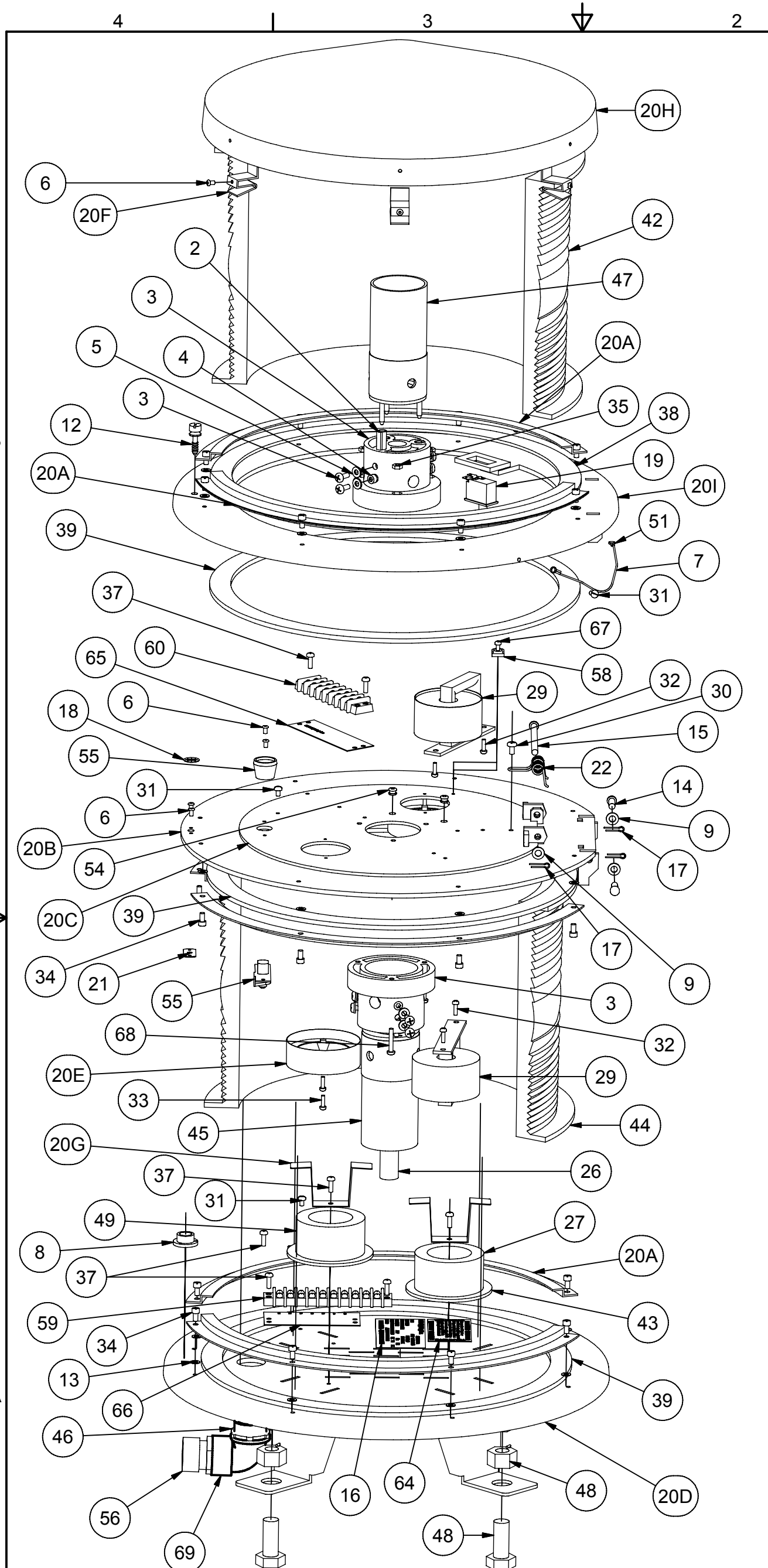

Parts List			
ITEM	QTY	PART NUMBER	DESCRIPTION
1	2	100319	DUAL BEACON FLASHTUBE SOCKET
2	6	BU27200	FLASHTUBE SOCKET INSERT
3	12	1032X12PHH	10-32 X 1/2 PHILLIPS BINDER SCREW
4	6	115510SS0	5/16 X 1/4 ROUND SS SPACER
5	6	1032FW	#10 SS FLAT WASHER
6	10	18PRSS-2	1/8 X .40 SS POP RIVET
7	2	7X7SS	1/16 HOL 7 X 7 SS WIRE
8	1	2-10000	CIRCULAR SPIRIT LEVEL
9	3	14FWDB	1/4 FLAT WASHER CH16L
10	2	* 18AWG BLU	#18AWG TEFLON BLUE WIRE
11	2	* 18AWG BRN	#18AWG TEFLON BROWN WIRE
12	1	121340712	DB QUICK OPEN CAPTIVE SCREW
13	24	8NFW	#8 NYLON FLAT WASHER
14	2	14X34CLVP	1/4 X 3/4 SHORT SS CLEVIS PIN
15	1	14X358CLVP	1/4 X 3-5/8 LONG SS CLEVIS PIN
16	1	STCONLAB2	Product Label
17	3	12SSCP	1/2" SS COTTER PIN
18	1	1261	SS RETAINER FOR QUICK OPEN
19	1	STJ02003	CHERRY SWITCH
20	1	*STDBFRAMKIT	DUAL BEACON FRAME KIT
20A	6	100337	DUAL BEACON LENS RETAINER RING
20B	1	100343	DUAL BEACON LOWER HINGE ASSEMBLY
20C	1	100345	DUAL BEACON HATCH PLATE
20D	1	100360	DUAL BEACON BASE ASSEMBLY
20E	2	100367	DUAL BEACON VENT CAP
20F	6	100368	DUAL BEACON CAP BRACKET
20G	2	100396	INDUCTOR BRACKET
20H	1	100344	CAP DUAL BEACON
20I	1	100342	DUAL BEACON UPPER HINGE ASSEMBLY
21	1	121102013	DB QUICK OPEN SCREW FLAT RECEPTACLE
22	1	070-4500	DB HATCH SPRING SS DWG100558
23	2	* 16AWGBLK	#16AWG TEFLON BLACK WIRE
24	1	* 16AWG RED/WHT	#16AWG TEFLON RED/WHITE WIRE
26	1	INSUTUBE	DUAL BEACON CERAMIC INSULATOR
27	1	INDCTRC3001	INDUCTOR 47MH TRANSFORMER
28	1	* 16AWG RED/BLK	#16AWG TEFLON RED/BLACK WIRE
29	2	STC05005	TRIGGER TRANSFORMER
30	1	1032X38PHH	10-32 X 3/8 PHILLIPS PAN HEAD SCREW
31	4	832X14PHH	8-32 X 1/4 PH SS SLOT SCREW
32	4	632X38PHH	6-32 X 3/8 PHILLIPS PAN HEAD SCREW
33	4	632X12PHH	6-32 X 1/2 PHILLIPS PAN HEAD SS SCREW
34	24	1032X38PHW	10-32 X 3/8 SS PHILIP HD CAPTIVE SCREW
35	3	832NUT	8-32 NUT
36	2	* 18RAD18277	T&B CONNECTOR
37	7	832X12PHH	8-32 X 1/2 PHILLIPS PAN HEAD
38	1	STBEAGSKT	GASKET NEOPRENE 13 1/4 X 15
39	3	STBEAGSK2	GASKET NEOPRENE 3/16 X 15 1/4
40	18	* TY223M	HI TEMP TY WRAPS
41	8	* 14RB10R	T&B CONNECTOR
42	1	STDBRENS	RED DB LENS
43	2	100394-02	INDUCTOR BOTOM PAD GASKET
44	1	STDBCLENS	CLEAR DB LENS
45	1	STFLSHTB6	DAY MODE TUBE G01-109
46	1	A315	1" CONDUIT LOCKNUT GALVANIZED
47	1	STFLSHTB7	NIGHT MODE TUBE G01-112
48	4	58X112	A325 5/8 X 1-1/2 BOLT W/ANCO L/NUT
49	1	100453	INDUCTOR 135uh
50	2	* HEATSHRINK2	1/2" GLUE BASE HEAT SHRINK
51	4	CSL062X100	1/16 COPPER SLEEVE
52	2	* 14RB8FL	STAKON
53	.25	* HEATSHRINK	1/4" RED HEAT SHRINK
54	2	A10290	5/32" ID RUBBER GROMMET
55	1	57-10-401-10	SOUTHCO SPRING LATCH W/BLACK KNOB
56	1	CC-MPT-1-G	1" CORD CONNECTOR .700 TO .984
57	1	* STDBEAPIGTAIL2	DUAL BEACON PIGTAIL
58	1	TYANCHOR	TY WRAP ANCHOR 23N3669
59	1	621 RZ 10	10 PART TERMINAL BLOCK
60	1	621 RZ 8	8 PART TERMINAL BLOCK
61	24	* 18RA6FL	STAKON
62	13	* 14RB-6FL	14-16 AWG #6 LOCKING FORK
63	3	* KV10-8F-D	10-12 AWG #8 LOCKING FORK
64	1	NONOEMLBL	NON-OEM PARTS WARNING LABEL
65	1	MS621XP08	MS8-141 CINCH TERMINAL MARKER
66	1	MS621XP10	MS10-141 CINCH TERMINAL MARKER
67	1	632X14PHH	6-32 X 1/4 PHILLIPS PAN HEAD SCREW
68	3	832X1PHH	8-32 X 1 PHILLIPS PAN HEAD SS SCREW
69	1	EL190S	1" 90 DEGREE SHORT ELBOW GALV

* ITEMS NOT SHOWN

DRAWN	Gavin Sebek	3/3/2004
PROD DEPT		
SERV DEPT		
ENGINEER		
APPROVED		

TWR Lighting, Inc.
Enlightened Technology

TITLE		
L865/864 DUAL BEACON ASSEMBLY (STDBEACON)		
SIZE	DWG NO	REV
B	100414	C
SCALE	SHEET 1 OF 1	