



10810 W LITTLE YORK RD. STE 130- HOUSTON TX 77041-4051

VOICE: 713-973-6905 - FAX: 713-973-9352

web: www.twrlighting.com

IMPORTANT!!!

PLEASE TAKE THE TIME TO FILL OUT THE FORM COMPLETELY. FILE IN A SAFE PLACE. IN THE EVENT YOU EXPERIENCE PROBLEMS WITH OR HAVE QUESTIONS CONCERNING YOUR CONTROLLER, THE FOLLOWING INFORMATION IS NECESSARY TO OBTAIN PROPER SERVICE AND PARTS.

MODEL # AA0TSS48VDCW/F (Lighting Controller)

SERIAL # _____

PURCHASE DATE _____

PURCHASED FROM _____



THIS PAGE IS INTENTIONALLY LEFT BLANK



Questions or information beyond this manual, please contact TWR Lighting, Inc.

TWR Lighting, Inc.
10810 W Little York Rd. Ste 130- Houston, TX 77041-4051
Voice: **713-973-6905** - Fax: **713-973-9352** – Toll Free: **800-661-8606**
E-mail: **techsupport@twrlighting.com**
web: www.twrlighting.com

The use of non-original manufacturer parts which are not approved by TWR Lighting, Inc. may invalidate the warranty as well as compliance with requirements as published in the FAA Advisory Circulars AC70/7460-1, AC150/5345-43 and AC150/5345-53 and ICAO Annex 14 standards.

DISCLAIMER

While every effort has been made to provide a complete, up-to-date, accurate manual, no liability claims for damages resulting from any errors or omissions in this manual will be accepted by TWR Lighting, Inc.

COPYRIGHT

Copyright © 2005 TWR Lighting, Inc.

All rights reserved. Reproduction or use of any part of this installation & operation manual is prohibited without express written permission from TWR Lighting, Inc.



Contents

| | | |
|-------|-----------------------------------|----|
| 1 | GENERAL INFORMATION | 5 |
| 2 | INSTALLATION | 5 |
| 2.1 | MOUNTING CONTROLLER | 5 |
| 2.1.1 | Controller mounting Inside | 5 |
| 2.1.2 | Controller mounted Outside | 6 |
| 2.2 | Controller wiring | 6 |
| 2.2.1 | External Photocell Wiring | 6 |
| 2.2.2 | Power Wiring | 6 |
| 2.2.3 | Obstruction Light wiring | 6 |
| 3 | Operation | 7 |
| 3.1 | Power Supply | 7 |
| 3.2 | Obstruction Light | 7 |
| 4 | Maintenance | 7 |
| 5 | MAJOR COMPONENTS PARTS LIST | 7 |
| 6 | WARRANTY AND RETURN POLICY | 8 |
| 6.1 | RMA FORM | 11 |
| 7 | CONTROLLER CHASSIS LAYOUT | 12 |



1 GENERAL INFORMATION

The TWR Lighting[®], Inc. (TWR[®]) Model AA0TSS48VDCW/F Controller is for the application of LED double obstruction fixture.

The obstruction light will be provided a pulsing voltage from this controller making the light flash at 30 flashes per minute in night mode.

A by-pass switch (SW1) allows the controller to be turned on during daylight hours without covering the photocell. This is particularly helpful since the controller can be mounted indoors while the photocell is outdoors. SW1 can be operated by turning “on” the toggle switch mounted on the panel of the controller.

The photocell is the three (3) blade, twist to lock, type.

Power supplied to the controller shall be 48 VDC.

Controller functions that are monitored by remote alarms in the form of dry contact closures (Form C) are as follows:

2 INSTALLATION

2.1 MOUNTING CONTROLLER

(Refer to Drawing 1326-R)

The power supply control cabinet can be located at the base of the structure or in an equipment building. Mounting footprints are shown on drawing 1196-R. Power wiring to the control cabinet should be in accordance with local methods and National Electrical Codes (NEC).

2.1.1 Controller mounting Inside

If the control cabinet is mounted inside an equipment building, the photocell should be mounted vertically on ½” conduit outside the building above the eaves facing north. Wiring from the photocell socket to the control cabinet should consist of one (1) each; red, black, and blue wires. The black wire is connected to the socket terminal marked “N,” the red wire is connected to the socket terminal marked “Li,” and the blue wire is connected to the socket terminal marked “Lo.” The photocell should be positioned so that it does not “see” ambient light, which would prevent it from switching to the night-mode.



2.1.2 Controller mounted Outside

If the control cabinet is mounted outside an equipment building, the photocell should be mounted vertically on ½" conduit so the photocell is above the control cabinet. Care must be taken to assure that the photocell does not "see" any ambient light that would prevent it from switching into the night-mode. The photocell wiring is the same as in 2.1.1.

2.2 Controller wiring

(Refer to Drawing 1326-R)

The wiring from the photocell, the battery, and the sidelights should enter the control cabinet through the watertight connectors in the bottom of the cabinet. Inside the cabinet, the connections will be made on the terminal strips and circuit breaker located at the bottom of the chassis. These connections are made as follows:

2.2.1 External Photocell Wiring

- A. Connect the **BLACK** wire from the photocell to terminal block TB2 marked "-."
- B. Connect the **RED** wire from the photocell to terminal block TB2 marked "SSR."
- C. Connect the **BLUE** wire from the photocell to terminal block TB2 marked "+."

2.2.2 Power Wiring

- A. Power wiring to the control cabinet should be in accordance with local methods and National Electrical Codes (NEC).
- B. Connect the positive 48 VDC to terminal block TB1 marked "+."
- C. Connect the negative wire to one (1) of the terminal blocks on TB1 marked "-."
- D. Connect the ground to the aluminum mounting plate.

2.2.3 Obstruction Light wiring

- A. Connect the **RED** from the double obstruction light to the circuit breaker marked "S."
- B. Connect the **BLACK** wire to the terminal block TB1 marked "-."
- C. Connect the ground to ground lug marked "G" inside the controller.



3 Operation

3.1 Power Supply

48V AC enters the controller from the circuit breaker panel. Line sits at the 6589C-FAA photocell waiting to be switched. When the 6589C-FAA photocell is activated, line SSR energizes M1 Flasher. This can also be accomplished by using the photocell by-pass switch (SW1).

3.2 Obstruction Light

SSR is being sent to Module M1 and then to the circuit breaker “S.” Module M1 is the Pulse voltage/Flasher for the obstruction fixtures.

4 Maintenance

This lighting system is constructed to be maintenance free. It is necessary to install all components and perform all tasks and described in this manual.

Testing of opened device under voltage should be avoided if possible and when required should be carried out only by a skilled person who is aware of the hazards involved.

Call TWR Technical Support 713-973-6905 Ext. #6

5 MAJOR COMPONENTS PARTS LIST

No spare parts are expected to be needed during the warranty period.

In case a site requires maintaining some spare parts at hand, the ‘SP’ marked parts can be bought in advance.

The warranty statement as written in this manual is applicable during the installation and and daily operation.

| QTY. | DESCRIPTION | PART NUMBER | SP |
|------|-----------------------------|----------------|----|
| 1 | PHOTOCELL | 6589C-FAA | Y |
| 1 | Controller Enclosure | VJ1008HPL1X004 | Y |
| 1 | Terminal Blocks (TB1 & TB2) | 8WA1204 | Y |
| 1 | Circuit Breaker | S261-D1 | Y |
| 1 | Terminal End Stop | 8WA1808 | Y |
| 1 | 20’ Photocell Pigtail | SSPIGTAIL | Y |
| 1 | 15 Amp SPDT Switch (SW1) | STJ01002 | Y |
| 1 | Flasher 30fpm | 24-120F30DF | Y |
| | | | |



6 WARRANTY AND RETURN POLICY

TWR Lighting®, Inc. (“TWR®”) warrants its products (other than “LED Product”) against defects in design, material (excluding incandescent bulbs) and workmanship for a period ending on the earlier of two (2) years from the date of shipment or one (1) year from the date of installation.

TWR Lighting®, Inc. (“TWR®”) warrants its “LED Product” against defects in design, material, and workmanship for a period of five (5) years from the date of shipment. TWR®, at its sole option, will, itself, or through others, repair, replace or refund the purchase price paid for “LED Product” that TWR® verifies as being inoperable due to original design, material, or workmanship. All warranty replacement “LED Product” is warranted only for the remainder of the original warranty of the “LED Product” replaced. Replacement “LED Product” will be equivalent in function, but not necessarily identical, to the replaced “LED Product.”

TWR Lighting®, Inc. (“TWR®”) warrants its “LED Product” against light degradation for a period of five (5) years from the date of installation. TWR®, at its sole option, will, itself, or through others, repair, replace or refund the purchase price paid for “LED Product” that TWR® verifies as failing to meet 75% of the minimum intensity requirements as defined in the FAA Advisory Circular 150/5345-43G dated

09/26/12. All warranty replacement “LED Product” is warranted only for the remainder of the original warranty of the “LED Product” replaced. Replacement “LED Product” will be equivalent in function, but not necessarily identical, to the replaced “LED Product.”

Replacement parts (other than “LED Product”) are warranted for 90 days from the date of shipment.

Conditions not covered by this Warranty, or which might void this Warranty are as follows:

- x Improper Installation or Operation
- x Misuse
- x Abuse
- x Unauthorized or Improper Repair or Alteration
- x Accident or Negligence in Use, Storage, Transportation, or Handling
- x Any Acts of God or Nature
- x Non-OEM Parts

The use of non-OEM parts or modifications to original equipment design will void the manufacturer warranty and could invalidate the assurance of complying with FAA requirements as published in Advisory Circular 150/5345-43.

Field Service – Repairs are warranted for 90 days from the date of service, except where TWR® has made recommendations that were not adhered to that may cause premature failure on previous repairs. Labor, Travel, and Tower Climb are not covered under warranty. Customer shall be obligated to pay for all incurred charges not related to warranty. All warranty repairs are performed by trained TWR® personnel or dispatched through an extensive network of certified and insured Service Representatives.

Return Terms – You must first contact our Customer Service Department at 713-973-6905 to acquire a Return Merchandise Authorization (RMA) number to return the product(s). Please have the following information available when requesting an RMA number:

- x The contact name and phone number of the tower owner
- x The contact name and phone number of the contractor
- x The site name and number
- x The part number(s)



Warranty & Return Policy

(continued)

- x The serial number(s) (if any)
- x A description of the problem
- x The billing information
- x The Ship To address

This RMA number must be clearly visible on the outside of the box. If the RMA number is not clearly labeled on the outside of the box, your shipment will be refused. Please ensure the material you are returning is packaged carefully. The warranty is null and void if the product(s) are damaged in the return shipment.

All RMAs must be received by TWR LIGHTING®, INC., 10810 W LITTLE YORK RD. #130, HOUSTON TX 77041-4, within 30 days of issuance.

Upon full compliance with the Return Terms, TWR® will replace, repair and return, or credit product(s) returned by the customer. It is TWR's sole discretion to determine the disposition of the returned item(s).

Replacements – Replacement part(s) will be shipped and billed to the customer for product(s) considered as Warranty, pending return of defective product(s). When available, a certified reconditioned part is shipped as warranty replacement with a Return Merchandise Authorization (RMA) number attached. Upon receipt of returned product(s), inspection, testing, and evaluation will be performed to determine the cause of defect. The customer is then notified of the determination of the testing.

- x Product(s) that is deemed defective and/or unrepairable and covered under warranty - a credit will be issued to the customer's account.
- x Product(s) found to have no defect will be subject to a \$75.00 per hour testing charge (1 hour minimum), which will be invoiced to the customer. At this time, the customer may decide to have the tested part(s) returned and is responsible for the return charges.
- x Product(s) under warranty, which the customer does not wish returned, the customer will be issued a credit against the replacement invoice.

Repair & Return – A Return Merchandise Authorization (RMA) will be issued for all part(s) returned to TWR® for repair. Upon receipt of returned product(s), inspection, testing and evaluation will be performed to determine the cause of defect. The customer is then notified of the determination of the testing. If the returned part(s) is deemed unrepairable, or the returned part(s) is found to have no defect, the customer will be subject to a \$75.00 per hour testing charge (1 hour minimum), which will be invoiced to the customer. Should the returned parts be determined to be repairable, a written estimated cost of repair will be sent to the customer for their written approval prior to any work being performed. To have the tested part(s) repaired and/or returned, the customer must issue a purchase order and is responsible for the return shipping charges.

Return to Stock – Any order that is returned to TWR® for part(s) ordered incorrectly by the customer, or unneeded upon receipt, the customer is required to pay a 20% restocking fee. A credit will be issued once it is determined that the Return Terms are met.

Credits – Credits are issued once it is determined that all the Warranty and Return Terms are met. All credits are processed on Fridays. In the event a Friday falls on a Holiday, the credit will be issued on the following Friday.

Freight – All warranty replacement part(s) will be shipped via ground delivery and paid for by TWR®. Delivery other than ground is the responsibility of the customer.



Warranty & Return Policy

(continued)

REMEDIES UNDER THIS WARRANTY ARE LIMITED TO PROVISIONS OF REPLACEMENT PARTS AND REPAIRS AS SPECIFICALLY PROVIDED. IN NO EVENT SHALL TWR® BE LIABLE FOR ANY OTHER LOSSES, DAMAGES, COSTS OR EXPENSES INCURRED BY THE CUSTOMER, INCLUDING, BUT NOT LIMITED TO, LOSS FROM FAILURE OF THE PRODUCT(S) TO OPERATE FOR ANY TIME, AND ALL OTHER DIRECT, INDIRECT, SPECIAL, INCIDENTAL, OR CONSEQUENTIAL DAMAGES, INCLUDING ALL PERSONAL INJURY OR PROPERTY DAMAGE DUE TO ALLEGED NEGLIGENCE, OR ANY OTHER LEGAL THEORY WHATSOEVER. THIS WARRANTY IS MADE BY TWR® EXPRESSLY IN LIEU OF ALL OTHER WARRANTIES, WHETHER EXPRESSED OR IMPLIED. WITHOUT LIMITING THE GENERALITY OF THE FORGOING, TWR® MAKES NO WARRANTY OF MERCHANTABILITY OR FITNESS OF THE PRODUCT(S) FOR ANY PARTICULAR PURPOSE. TWR® EXPRESSLY DISCLAIMS ALL OTHER WARRANTIES.



6.1 RMA FORM

RMA-Form

| | | |
|---|---|--|
|  | | RETURN MATERIAL AUTHORIZATION FORM |
| Please send this form together with the defect product to TWR Lighting, Inc. | | |
| TWR Lighting, Inc. reference RMA # | : | |
| Date (mm-dd-yyyy) | : | |
| Number of pages | : | 1 of |
| Customer name | : | |
| Contact person | : | |
| Delivery address | : | TWR Lighting, Inc., 10810 W Little York Rd. #130 Houston, Tx 77041 |
| Department | : | Service |
| Telephone | : | (713) 973-6905 |
| Fax | : | (713) 973-9352 |
| Dear customer, | | |
| Please fill in this form completely and return it to the above fax number without indicating an RMA number. The RMA number will be immediately generated by us. Please complete the following questions. Use one sheet for each item that is returned. | | |
| Customer reference RMA nr. | : | |
| Site location | : | |
| Product type | : | |
| Serial number | : | |
| Reason for return delivery | : | |
| Initial TWR Lighting, Inc. PO (order) number | : | |
| Warranty claimed | : | Yes / No |
| Replacement product needed in advance? | : | Yes / No |
| Inspection costs in the amount of \$75.00 will be charged for each product. When a replacement product is ordered, the inspection cost will be calculated in the price. | | |



7 CONTROLLER CHASSIS LAYOUT

9"X7" PLATE

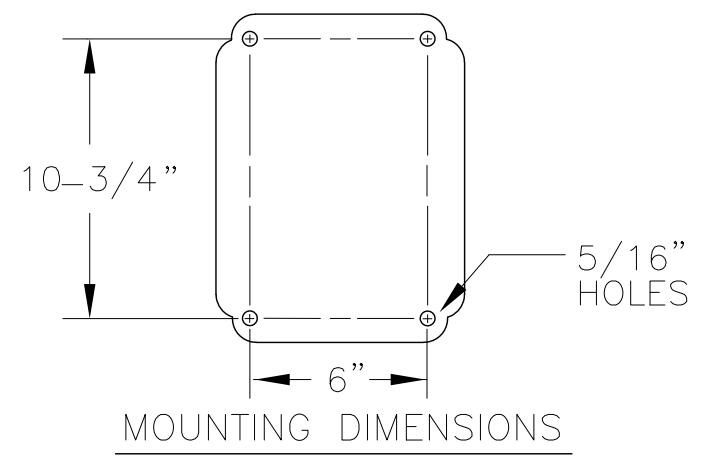
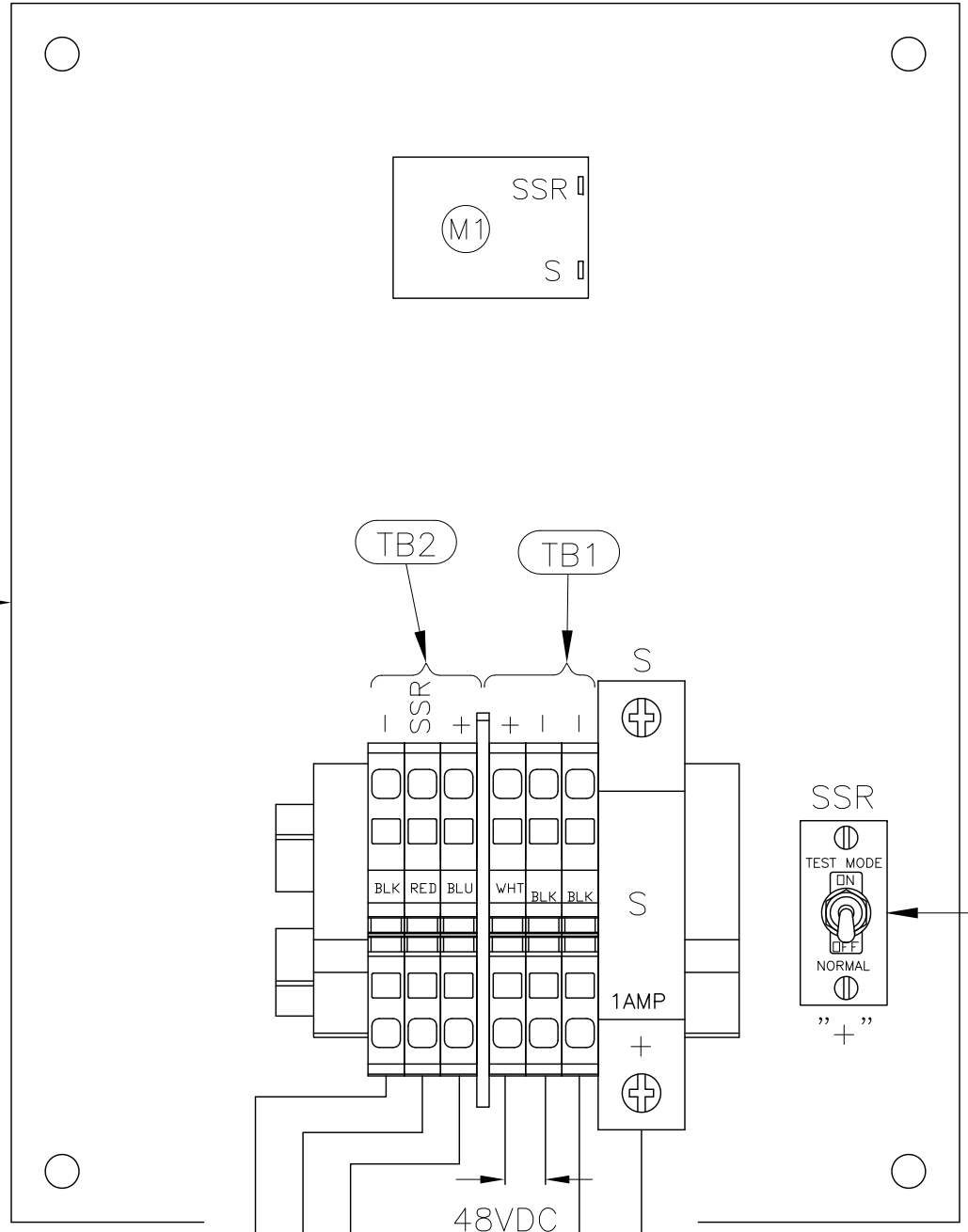

- NOTES: (FOR CABINET)
1. PLUG FAA PHOTOCCELL INTO 43109 TWIST LOCK RECEPTACLE AND TWIST TO LOCK.
 2. WIRES ARE CONNECTED LETTER TO LETTER. (EXAMPLE) N TO N...

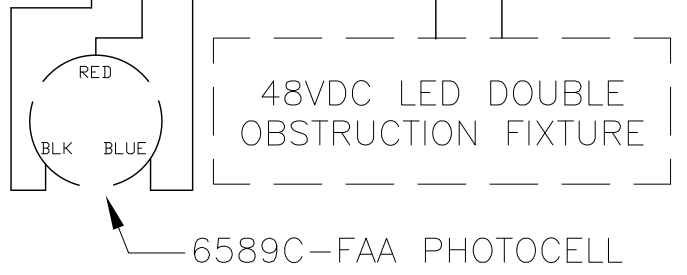

| | | | |
|--|-----------------|--------------------------------------|--|
| <u>AA0TSS48VDCWF CHASSIS LAYOUT</u> | | | |
| APPROVED BY | | TWR Enlightened Technology | |
| APPROVED BY | | | |
| APPROVED BY | | | |
| DRAWN BY GDS | SIZE B | SHEET QTY. 1 OF 1 | |
| DATE 7/26/2021 | SCALE N.T.S. | DWG. NO. 1326-R | |
| <small>The use of non-OEM parts or modifications to original equipment design will void the manufacturer warranty and could invalidate the assurance of complying with FAA requirements as published in Advisory Circular 150/5345-43.</small> <small>NOTICE: The drawings and photographic images contained herein are the sole property of TWR Lighting, Inc. All information contained herein that is not generally known shall be considered confidential except to the extent the information has been previously established. The drawings and photographic images contained herein may not be reproduced, copied or used as the basis for manufacture or sale or promotion or any other purpose without the expressed written permission of TWR Lighting, Inc.</small> | | | |